

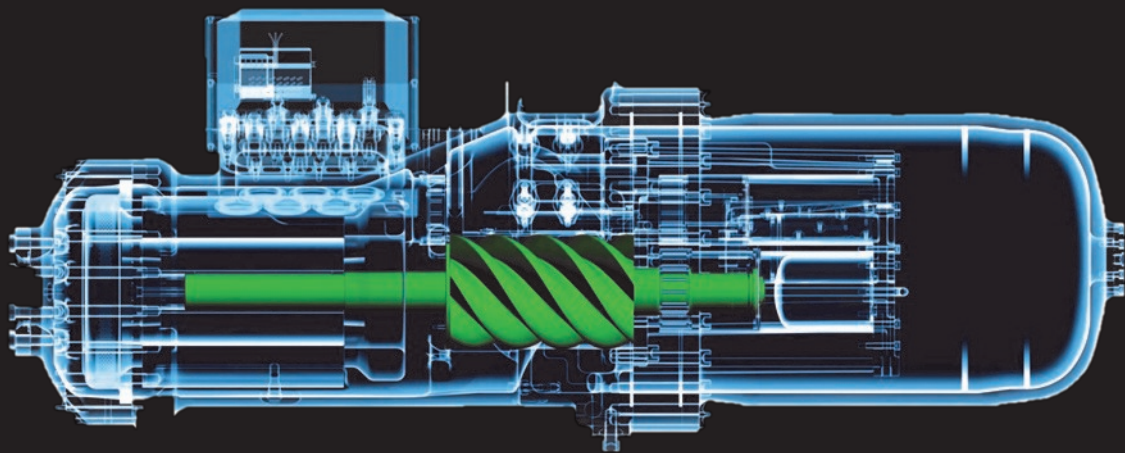

BITZER Screw Compressor

COMPETITIVE COMPRESSOR CONVERSION GUIDE

FOR CSH AND CSW MODELS



XR-0034-01 // Revision 5/2016 // US VERSION



The intention of this document is to serve as general guidelines. The information contained is not intended to replace specific equipment and/or system manufacturer's information or guidelines. BITZER implies no liability for the information contained. It is BITZER's implicit intention that nothing contained in this guide replaces any past, present or future warranty policy of BITZER and/or any other manufacturer's equipment

These guidelines are not a replacement for information specific to that of the manufacturer or the manufacturer's system technical product information.

Each system may vary in design, usage and specifications. This document is intended for use specific to the compressor only and not intended to be a "catch all" for any and every possible application of the compressor.

BITZER's intention is that only qualified and certified (where applicable) individuals specific to the refrigeration industry use the information contained and all standard refrigeration handling and safety practices must be followed at all times.

BITZER's intention is that all electric work is performed by qualified and certified (where applicable) individuals and all standard electrical safety practices must be followed at all times.

The advice given herein and/or any conclusions made by BITZER US, Inc. represent BITZER US, Inc's best advice and judgment under the circumstances, but such advice and/or conclusions made or results obtained shall be deemed used at your sole risk. For further assistance, please contact our application engineering department.

BITZER Aftermarket Solutions

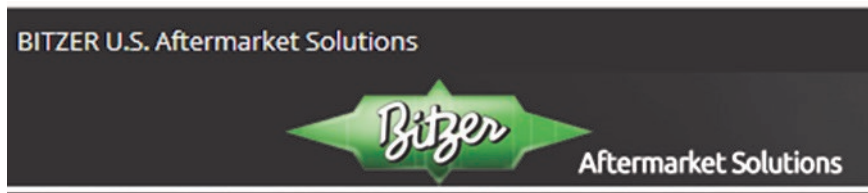

The goal of this site is to provide our A/C & Refrigeration Contractors the following information

- // Application & Operation Tips for Service Compressors
- // BITZER News & Product Updates
- // Miscellaneous Forms & Apps

AUTHORIZED DEALER LOGIN

A background image showing a blue airplane flying in the sky above a detailed technical drawing of industrial machinery, likely a compressor or refrigeration system.

BITZER Contractors have replaced over 475 different models of screw compressors manufactured by over 14 different companies with BITZER high efficiency screw compressors.

Visit: www.bitzerams.com for more information.

BITZER PT Reference App



Download the BITZER app to your smartphone!
Available for Apple and Android devices.

CONTENTS

	Page
1 General Information	
1.1 Contact Information	7
1.2 CS Series Nomenclature	8
1.3 BITZER Oils and Part Numbers for CS Screw Compressors	9
2 BITZER CS Series Cross Reference Charts by CFH Ratings	
2.1 CSH R134A Optimized Compressors with Evaporating Temps <55°F	10
2.2 CSW R134A Optimized Compressors	11
2.3 CSH R22 Compressors	12
2.4 CSW R22 Compressors With Condensing Temperatures <115°F	13
3 BITZER Screw Cross Reference Based on Capacity	
3.1 Carlyle 5H Series to BITZER CS Series Compressors	14
3.2 McQuay ALS Series with Sizes 155, 167 and 175	15
3.3 York YCAS and YCWS DXS Series with R22	16
4 Compressor Data	
4.1 CSH65 Outline Drawings	17
4.2 CSH75 Outline Drawings	18
4.3 CSH85 Outline Drawings	19
4.4 CSH95 Outline Drawings	20
4.5 CSW65 Outline Drawings	21
4.6 CSW75 Outline Drawings	22
4.7 CSW85 Outline Drawings	23
4.8 CSW95 Outline Drawings	24
4.9 Connection Positions	25
4.10 Compressor Technical Data CSH65 and 75 Series	26
4.11 Compressor Technical Data CSH85 and 95 Series	27
4.12 Compressor Technical Data CSW Series	28
4.13 Operating Parameters	29
5 CSH and CSW Solenoid Valve Identification	
5.1 CS Solenoid Layout	30
5.2 CS Solenoid Operation	31
6 Electrical Information	
6.1 SE-E1 / SE-E2 Modules and Wiring	32
6.2 Wiring for Protection Devices	33
6.3 UL Motor Codes	34
6.4 Electrical Connection PWS Motors	35
6.5 Electrical Connection Star Delta Motors	36
7 Accessories and Options	
7.1 Mechanical Oil Level Control (CSH.3)	37
7.2 Optical Oil Level Control (CSW and CSH.3)	38
7.3 CS 65-75-85 Mounting Rails	39
7.4 CSH.3 Liquid Injection	40
8 FuSheng SR Series to BITZER CS Series	
8.1 Overview	41
8.2 Scope of Standard Delivery	42
8.3 Capacity Control	43
8.4 Module and Starting Types	44
8.5 Dimensions, Connections and Oil Types	45
8.6 Compressor Conversion Pictures	46
8.7 CFH and Motor Horsepower Ratings	47

CONTENTS

9 Hanbell RC Series to BITZER CS	
9.1 Overview	48
9.2 Scope of Standard Delivery	49
9.3 Motor Horsepower Ratings	50
9.4 Model Number Nomenclature	51
9.5 Modules and Wiring	52
9.6 Starting Types	54
9.7 Capacity Control	55
9.8 Oil and Refrigerant Types	57
9.9 Connection Sizes and Weight Comparisons	58
9.10 Outline Drawings	59
10 Hartford Dunham Bush NHF Series	
10.1 Overview	61
10.2 Scope of Standard Delivery	62
10.3 Model Number Nomenclature and Oil Type	63
10.4 Capacity Control	64
10.5 Modules and Wiring	65
10.6 Starting Types and Terminal Box Wiring	67
10.7 Outline Drawings	68
10.8 Compressor Conversion Examples	70
10.9 Connection Sizes and Weights	71
11 Hitachi SC Series to BITZER CS	
11.1 Overview	72
11.2 Scope of Standard Delivery	73
11.3 Motor Horsepower and CFH Comparison	74
11.4 Dimension, Weight, Connection and Oil Comparison	75
11.5 Capacity Control	76
11.6 Module and Terminal Wiring	78
11.7 Outline Drawings	80
11.8 Compressor Conversion Examples	81
12 RefComp SRC Series to BITZER CS	
12.1 Overview	83
12.2 Scope of Standard Delivery	84
12.3 Model Number Nomenclature and Oil Type	85
12.4 Capacity Control	86
12.5 Module Types and Wiring	88
12.6 Dimension, Weights and Connections	89
12.7 Outline Drawings	90
13 McQuay ALS Series to BITZER CS	
13.1 Overview	92
13.2 Scope of Standard Delivery	93
13.3 McQuay Chiller Model Numbers and Oil Type	94
13.4 Dimensions and Connection Sizes	97
13.5 Capacity Control	98
13.6 Oil Separator and Piping Components	101
13.7 High Pressure Switch	102
13.8 Installation Example	103
13.9 Piping Example	104
13.10 Electrical Information	107
13.11 Component Operation	109
13.12 McQuay Dimensional Data	110

CONTENTS

14 York YCAS and YCWS to BITZER CS

14.1 Overview	111
14.2 Scope of Standard Delivery	112
14.3 Model Number Nomenclature	113
14.4 Millennium Style “F” Chillers 80-420 Tons	114
14.5 Dimensions, Valve Connections and Oil Type	115
14.6 Capacity Control	116
14.7 Component Pictures and Layout	117
14.8 Preparing for Removal	119
14.9 Installing the BITZER CS Screw Compressor	121
14.10 Modules and Electrical Information	124
14.11 Piping	126
14.12 Liquid Injection Oil Cooling	128
14.13 York DXS Compressor Layout Drawings	129

15 Carlyle 5H Series to BITZER CS Series

15.1 Overview	131
15.2 Scope of Standard Delivery	132
15.3 Model Number Nomenclature and Oil Charge	133
15.4 Capacity Control	134
15.5 Dimension and Weight Comparison	135
15.6 Connection Size and Oil Type	136
15.7 5H Series Outline Drawings	137
15.8 5H Series to BITZER CS Series Conversion Pictures	139

16 Technical Documentation

16.1 Official BITZER Literature	140
16.2 Official BITZER US Literature	141

1.1 BITZER Contact Information

BITZER US, Inc

4080 Enterprise Way
Flowery Branch, GA 30542
Phone: 770-503-9226
Fax: 770-503-9440

www.bitzerus.com

Email: customerservice@bitzerus.com
sales@bitzerus.com
techsupport@bitzerus.com

**24hr Quick Ship Emergency Replacement Hotline
for US Customers:
1-888-GO BITZER (1-888-462-4893)**

BITZER Canada Inc.

21125 Daoust Street
Sainte-Anne-De-Bellevue, QC, H9X 0A3
Canada
Phone: 514-697-3363
Fax: 514-697-9768

www.bitzer.ca

BITZER México S de RL de CV

Av. Adolfo López Mateos 221 Bodega 9
Col. Victoria
Guadalupe, N.L., 67110, México
Phone: +52 (81) 1522 4500
Fax: +52 (81) 1522 4505

www.bitzermexico.com

BITZER US – Latin America

Phone +1 770 718 2914
ecuador@bitzerus.com
colombia@bitzerus.com
venezuela@bitzerus.com
puertorico@bitzerus.com
caribe@bitzerus.com
centroamerica@bitzerus.com

1.2 BITZER CS Screw Nomenclature

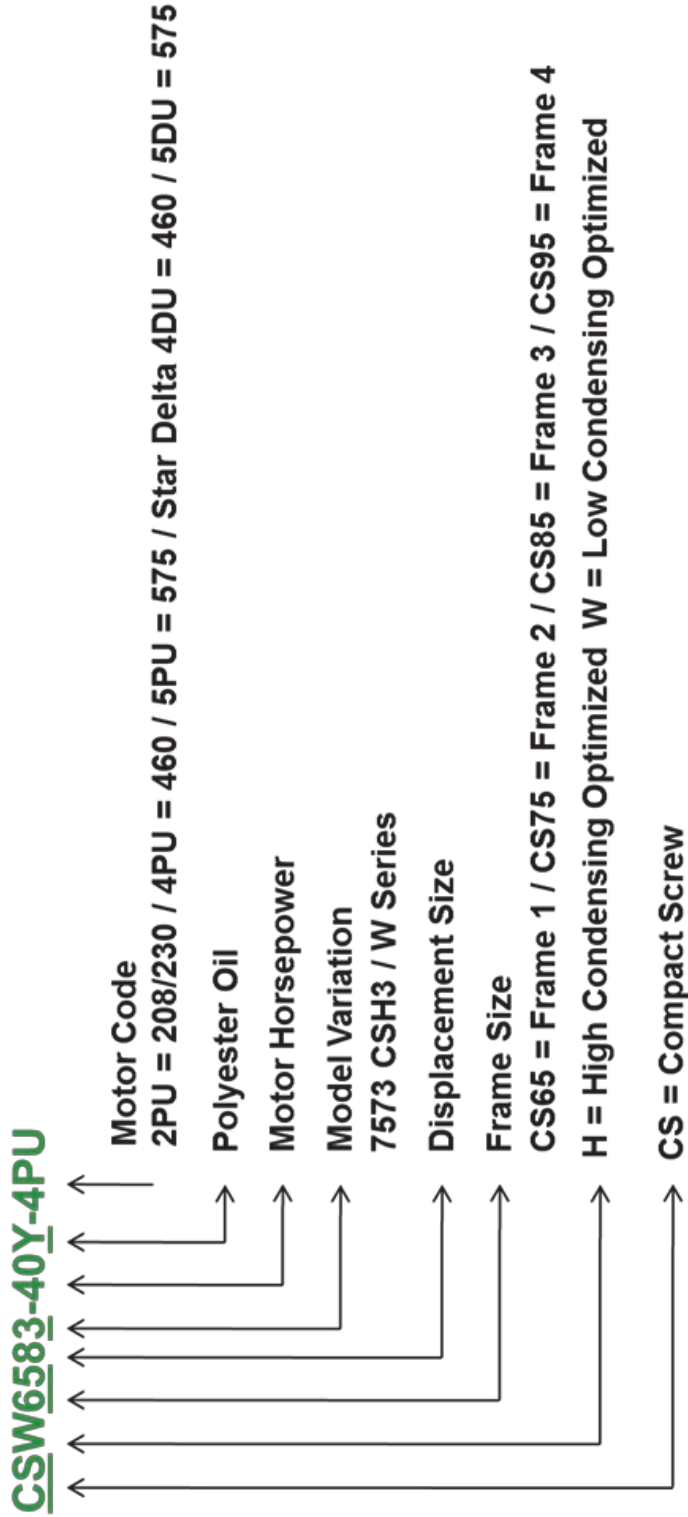

“Y” after the 11th Digit is Oil Type (when required)

“Y” = BSE170 for R407C / If no “Y” in Model Number = B320SH for R22

“Y” = BSE170L for R134A Only

1.3 BITZER Oils and Part Numbers for CS Screw Compressors

BITZER Approved Oils

Model	Refrigerant	Oil Type	5 Gal	1 Gal
CSH	R134A R407C R404A R507A	BSE170	793-3170-34	793-1170-34
	R22	B320SH	793-3320-34	793-3320-01
CSW	R134A	BSE170L	915188-02* (10L)	915118-01* (5L)
	R134A R407C R404A R507A	BSE170	793-3170-34	793-1170-34
	R22	B320SH	793-3320-34	793-3320-01

(*BSE-170L is packaged in liter containers)

Approved Alternative Oils

BITZER Oil	Alternative Oil	Manufacturer
BSE170 (POE 170)	Solest 170	CPI
	Emkarate RL170 H	Uniquema
	Zerol 150	Petrosynthese
	Reniso SE170	Fuchs
There are no approved Alternative Oils for B320SH or BSE170L		

2 BITZER Screw Cross Reference Based on CFH Comparison

2.1 BITZER CSH R134A Optimized Compressors with Evaporating Temps <55°F

BITZER CSH Series R134A Cross Reference Recommendation by CFH								
BITZER Optimized R134A CSH Compressors for Evaporating Temperatures Less Than 55°								
CFH Range	BITZER CSH	Hanbell RC2-A	FuSheng SR(A)	RefComp SRC	Hartford NHF	Hitachi	Carlyle 06T	Carlyle 06NA/W
4000-5000		RC2-100A						
5000-6000		RC2-140A		134-XS-40				
6000	CSH6553-35Y*		SRA-1			4002/5 SC		06NA/W-123
6250				134-XS-50				
7000					1111NHL			
7250	CSH6563-40Y*	RC2-170A				5002/5 SC		
7500				134-XS-60				
7750		RC2-180A	SRA-2					
8000								
8250	CSH6583-50Y*	RC2-200A					06TSA137-G1C	
8500	CSH7553-50Y*							
8750					1113NHL	6002/5 SC		06NA/W-146
9250							06TSA155-J1C	
9500	CSH6593-60Y*		SRA-3	134-S-71				
9750	CSH7563-60Y*	RC2-230A						
10500					1117NHL			06NA/W-174
11000	CSH7573-70Y*	RC2-260A		134-S-81	1210NHL		06TSA186-J1C	
12000				134-S-91				
12500	CSH7583-80Y*	RC2-300A	SRA-4					06NA/W-209
13000		RC2-310A						
13500	CSH8553-80Y*	RC2-320A		134-S-101				
14000					1212NHL	10001 SC		
14500	CSH7593-90Y*	RC2-340A		134-S-110				
15000								06NA/W-250
15500	CSH8563-90Y*	RC2-370A	SRA-434					
16000							06TTA266-P1C	
16500					1215NHL			
17000				134-S-120				
17500	CSH8573-110Y*	RC2-410A						
18000							06TTA301-11C	06NA/W-300
18500			SRA-5					
20000	CSH8583-125Y*	RC2-470A		134-S-140	1218NHL			
20500								
21000			SRA-561					
21500		RC2-510A					06TTA356-S1C	
22500	CSH8593-140Y*			134-S-160				
23000								
23500		RC2-550A	SRA-6					
24500				134-S-180				
25000		RC2-580A						
26000	CSH9563-160Y*	RC2-610A						
26500		RC2-620A						
28500				134-S-210				
29000	CSH9573-180Y*						06TUA483-W1C	
29500			SRA-7					
30000				134-S-220				
30500		RC2-710A						
32000			SRA-8	134-S-240				
33000							06TUA554-W1C	
33500		RC2-790A						
34000	CSH9583-210Y*	RC2-830A		134-S-270				
39000	CSH9593-240Y*	RC2-930A		134-S-300				
43000	CSH95103-280Y*	RC2-1020A						
48000	CSH95113-320Y*							

2 BITZER Screw Cross Reference Based on CFH Comparison

2.2 BITZER CSW R134A Optimized Compressors

BITZER CSW Series R134A Cross Reference Recommendation by CFH								
CFH Range	BITZER CSW	Handbell RC2-A	FuSheng SR(A)	RefComp SRC	Hartford NHF	Hitachi	Carlyle 06T	Carlyle 06NA/W
5000-6000			SRA-1	134-XS-040		4002/5 SC		
6000-7000				134-XS-050	1111NHL	5002/5 SC		
7000-8000			SRA-2	134-XS-060				06NA/W-123
8250	CSW6583-50	RC2-200A					06TSA137-G1C	
8750					1113NHL			06NA/W-146
9000						6002/5 SC		
9250							06TSA155-J1C	
9500	CSW6593-60		SRA-3	134-S-71				
9750		RC2-230A						
10500					1117NHL			06NA/W-174
11000	CSW7573-70	RC2-260A		134-S-81	1210NHL		06TSA186-J1C	
12000								
12500	CSW7583-80	RC2-300A	SRA-4	134-S-91				06NA/W-209
13500		RC2-320A		134-S-101				
14000					1212NHL	10001 SC		
14500	CSW7593-90			134-S-110				
15000								06NA/W-250
15500			SRA-434					
16000							06TTA266-P1C	
16500					1215NHL			
17000				134-S-120				
17500	CSW8573-110	RC2-410A						
18000							06TTA301-11C	06NA/W-300
18500			SRA-5					
20000	CSW8583-125	RC2-470A		134-S-140	1218NHL			
21000			SRA-561					
21500		RC2-510A					06TTA356-S1C	
22500	CSW8593-140			134-S-160				
23500			SRA-6					
24500				134-S-180				
26000	CSW9563-160	RC2-620A						
28500				134-S-210				
29000							06TUA483-W1C	
30000	CSW9573-180		SRA-7	134-S-220				
32000				134-S-240				
32500			SRA-8					
33000							06TUA554-W1C	
34000		RC2-790A						
34500	CSW9583-210							
35500				134-S-270				
39000	CSW9593-240			134-S-300				

2 BITZER Screw Cross Reference Based on CFH Comparison

2.3 BITZER CSH R22 Compressors

BITZER CSH Series R22 Cross Reference Recommendation by CFH							
CFH Range	BITZER CSH	Handbell RC2-B	FuSheng SR(H)	RefComp SRC	Hartford NHF	Dunham Bush w/Hitachi	Hitachi
5000-6000				SRC-XS-040			
6000	CSH6553-50	RC2-140B	SR1(H)			SSCA050AR	4002/5 SC
6250				SRC-XS-050			
6500				SRC-S-133			
7000					1111NHF		
7250	CSH6563-60	RC2-170B		SRC-XS-060		SSCA060AR	5002/5 SC
7500		RC2-180B		SRC-S-163			
7750			SR2(H)				
8250		RC2-200B					
8500	CSH7553-70						
8750					1113NHF		
9000				SRC-S-183		SSCA075AR	6002/5 SC
9500			SR3(H)				
9750	CSH7563-80	RC2-230B					
10000		RC2-260B		SRC-S-213			
10500					1117NHF		
11000	CSH7573-90				1210NHF		
12500	CSH7583-100	RC2-300B	SR4(H)	SRC-S-253			
13000							
13500	CSH8553-110	RC2-320B		SRC-S-285			
14000					1212NHF		10001 SC
14500	CSH7593-110	RC2-340B		SRC-S-303			
15500	CSH8563-125	RC2-370B	SR434(H)				
17000					1215NHF		
17500	CSH8573-140	RC2-410B		SRC-S-353			
18500			SR5(H)				
19000				SRC-S-413			
20000	CSH8583-160	RC2-470B			1218NHF		
21000			SR561(H)				
21500		RC2-510B					
22000				SRC-S-453			
23000	CSH9553-180	RC2-550B					
23500			SR6(H)				
24000				SRC-S-503			
25000		RC2-580B					
26000	CSH9563-210	RC2-620B		SRC-S-553			
29750	CSH9573-240		SR7(H)	SRC-S-603			
32500			SR8(H)				
33500		RC2-790B					
35400	CSH9583-280						
39000	CSH9593-300						

2 BITZER Screw Cross Reference Based on CFH Comparison

2.4 BITZER CSW R22 Compressors With Condensing Temperatures <115°F

BITZER CSW Series R22 Cross Reference Recommendation by CFH							
Condensing Temperature Lower Than 115°							
CFH Range	BITZER CSW	Handbell RC2-B	FuSheng SR(H)	RefComp SRC	Hartford NHF	Dunham Bush w/Hitachi	Hitachi
5000-6000		RC2-140B	SR1(H)	SRC-S-113		SSCA050AR	4002/5 SC
6000-7000				SRC-S-133	1111NHF	SSCA060AR	5002/5 SC
7000-8000		RC2-170B		SRC-S-163			
8000		RC2-180B	SR2(H)				
8250	CSW6583-50	RC2-200B					
8750				SRC-S-183	1113NHF		
9000						SSCA075AR	6002/5 SC
9500	CSW6593-60		SR3(H)				
9750		RC2-230B					
10000							
10500				SRC-S-213	1117NHF		
11000	CSW7573-70	RC2-260B	SR4(H)	SRC-S-253	1210NHF		
12500	CSW7583-80	RC2-300B					
13500		RC2-320B		SRC-S-285			
14000					1212NHF		10001 SC
14500	CSW7593-90	RC2-340B		SRC-S-303			
15000			SR434(H)				
15500		RC2-370B					
16500					1215NHF		
17500	CSW8573-110	RC2-410B		SRC-S-353			
18000			SR5(H)				
19000				SRC-S-413			
20000	CSW8583-125	RC2-470B			1218NHF		
21000			SR561(H)				
21500		RC2-510B		SRC-S-453			
22500	CSW8593-140						
23000		RC2-550B					
23500			SR6(H)				
24000				SRC-S-503			
25000		RC2-580B					
25500				SRC-S-553			
26000	CSW9563-160	RC2-620B					
29750	CSW9573-180		SR7(H)	SRC-S-603			
30000			SR8(H)				
33000							
33500		RC2-790B					
34000							
34500	CSW9583-210						
39000	CSW9593-240	RC2-930B					

3 BITZER Screw Cross Reference Based on Capacity

3.1 Carlyle 5H Series to BITZER CS Series Compressors

Carlyle 5H Series					
Model Number	CFM	CFH	HP	Tons 40/105/15/0 R22 1750 rpm	Tons 36/122/10/15 R22 1750 rpm
5H40	92	5544	40	40.0	29.7
5H46	116	6930	60	49.6	43.1
5H60	138	8304	60	60.1	51.7
5H66	173	10380	75	74.6	59.3
5H80	185	11082	75	80.2	68.7
5H86	231	13860	100	99.5	85.5
5H120	277	16608	125	120.3	103.1
5H126	346	20760	150	149.3	128.5

BITZER CSH Series					
Model Number	CFM	CFH	HP	Tons 40/105/15/0 R22	Tons 36/122/10/15 R22
CSH6553-50	97	5830	50	42	37
CSH6563-60	121	7244	60	52	46
CSH7553-70	140	8410	70	61	53
CSH7563-80	161	9682	80	71	61
CSH7573-90	183	10989	90	85	75
CSH7583-100	210	12572	100	94	83
CSH7593-110	239	14338	110	108	94
CSH8553-110	224	13428	110	102	88
CSH8563-125	255	15300	125	117	101
CSH8573-140	292	17491	140	137	121

BITZER CSW Series				
Model Number	CFM	CFH	HP	Tons 40/105/15/0 R22
CSW6583-50	138	8299	50	64
CSW6593-60	155	9323	60	52
CSW7573-70	183	10989	70	88
CSW7583-80	210	12572	80	101
CSW7593-90	239	14338	90	115
CSW8573-110	292	17491	110	142

3 BITZER Screw Cross Reference Based on Capacity

3.2 McQuay ALS Series with Sizes 155, 167 and 175

Recommended CS Replacement			
36°sst 122°cdt 10°sh 15°sc R22			
Compressor	Tons	Compressor	Tons
Size 155	65	CSH7563-80	62
Size 167	80	CSH7573-90	75
		CSH7583-100	83
Size 175	95	CSH7593-110	94
		CSH8553-110	88
		CSH8563-125	100

Recommended CS Replacement			
36°sst 122°cdt 10°sh 15°sc R22 Economized			
Compressor	Tons	Compressor	Tons
Size 155	65	CSH7563-80	67
Size 167	80	CSH7573-90	80
Size 175	95	CSH7583-100	90
		CSH7593-110	100

Optional CSW Replacement			
36°sst 122°cdt 10°sh 15°sc R22			
Size 155	65	CSW6593-60	62
Size 167	80	CSW7573-70	75
		CSW7583-80	85
Size 175	95	CSW7593-90	97
**CSW is at the upper CDT limit of 122°			
**Minimum Capacity with CSW is 50% at 122°CDT			
** Consult BITZER Software			

3 BITZER Screw Cross Reference Based on Capacity

3.3 York YCAS and YCWS DXS Series with R22

YORK Compressor	Tons	CSH Air Cooled	Tons
DXS112	42	CSH6563-60	44
		CSH7553-70	51
DXS124	62	CSH7563-80	59
		CSH7573-90	71
DXS136	78	CSH7583-100	79
DXS145	95	CSH7593-110	90
		CSH8553-110	84
		CSH8563-125	96
CS' Compressor Ratings Are Matched to York Data by Using BITZER Software and the Inputs: R22 @ 36°sst / 122°cdt / 5°F Subcooling / 10°F Superheat			

YORK Compressor	Tons	CSH / CSW Water Cooled	Tons
DXS112	42	CSH6553-50	42
DXS124	62	CSW6583-50	64
DXS136	78	CSW6593-60	73
DXS145	95	CSW7573-70	89
		CSW7583-80	100
CS' Compressor Ratings Are Matched to York Data by Using BITZER Software and the Inputs: R22 @ 39°sst / 105°cdt / 5°F Subcooling / 10°F Superheat			

4 Compressor Data

4.1 CSH65 Outline Drawings

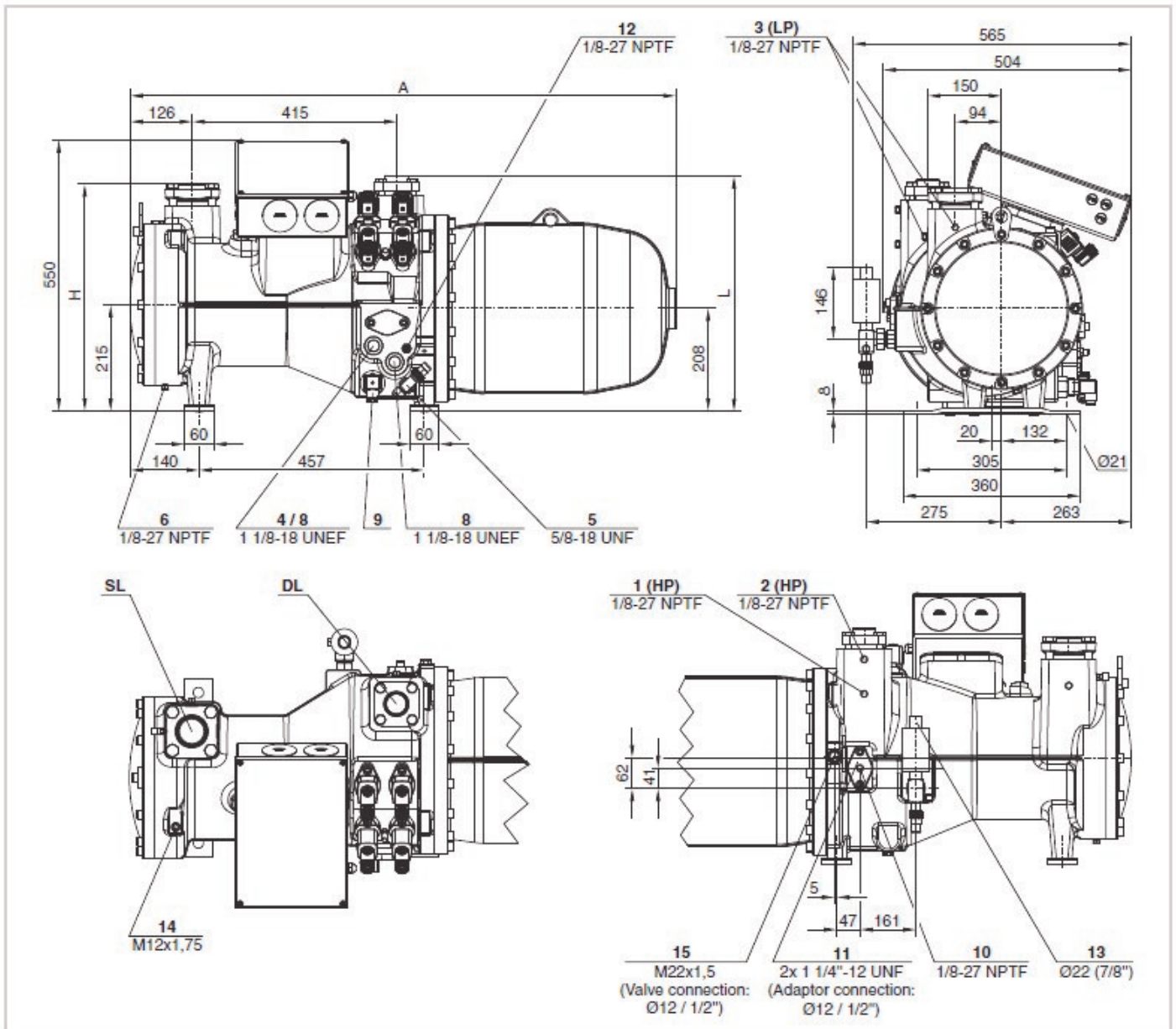

4.2 CSH75 Outline Drawings

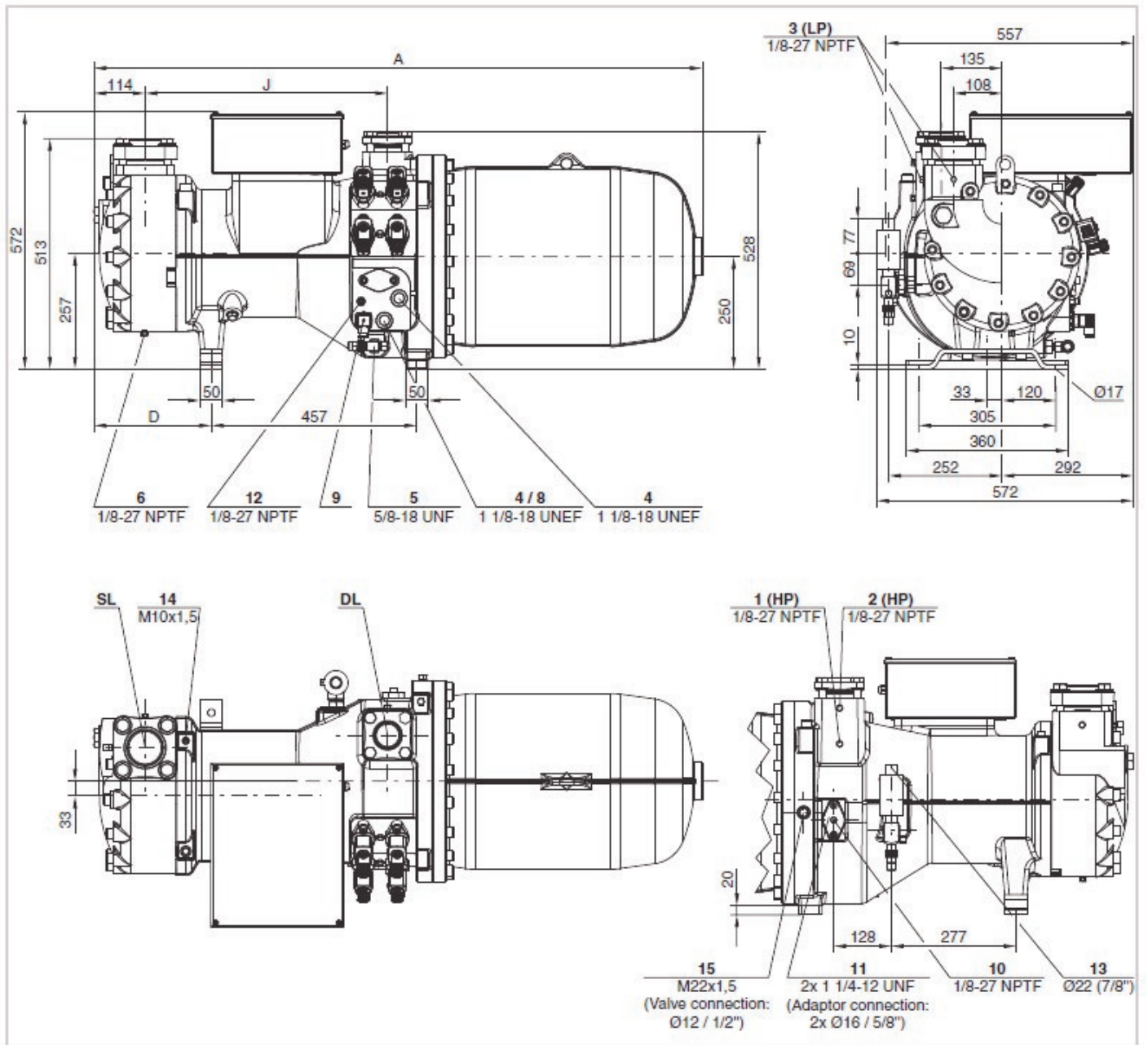

4 Compressor Data

4.3 CSH85 Outline Drawings

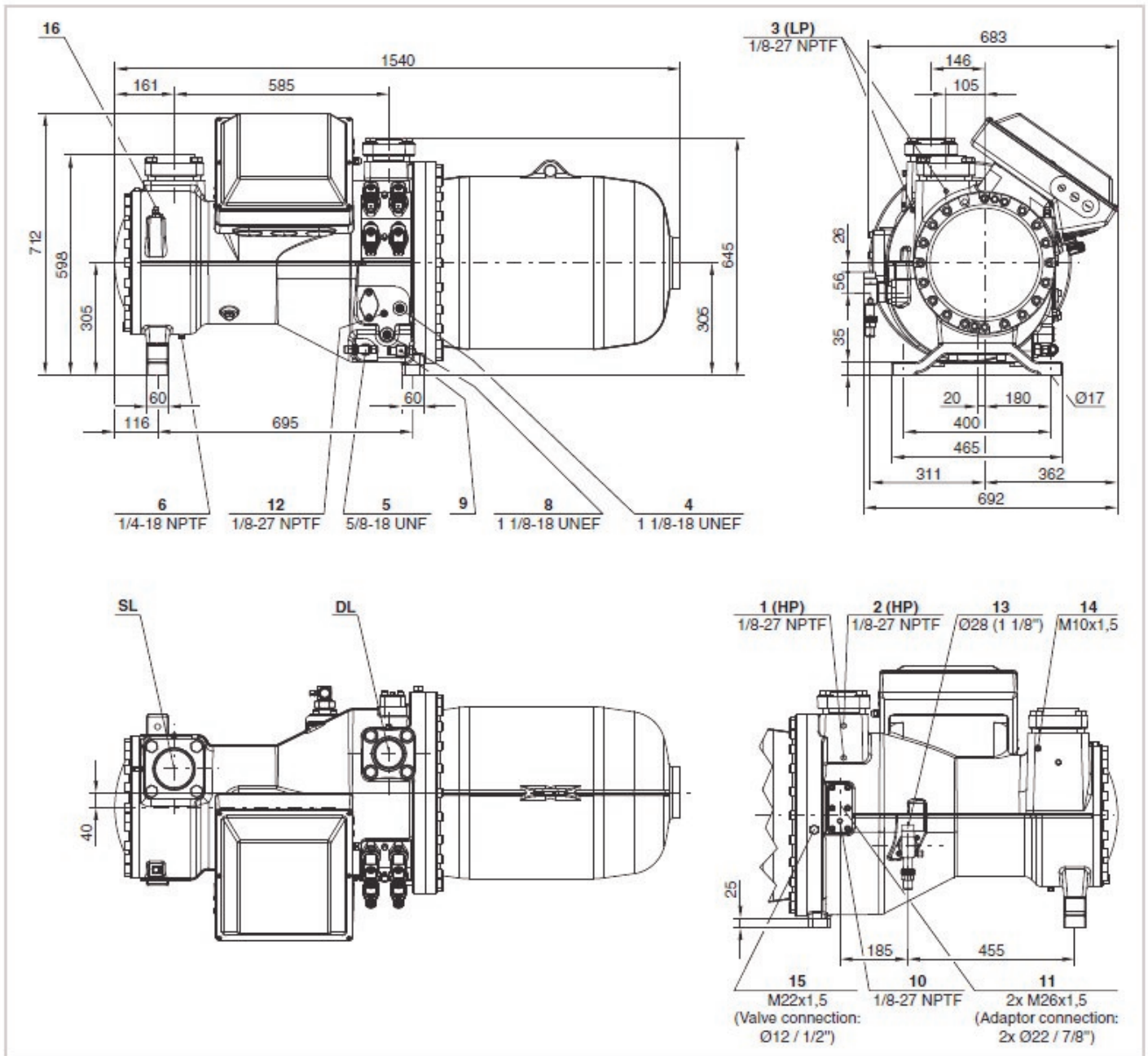

4.4 CSH95 Outline Drawings

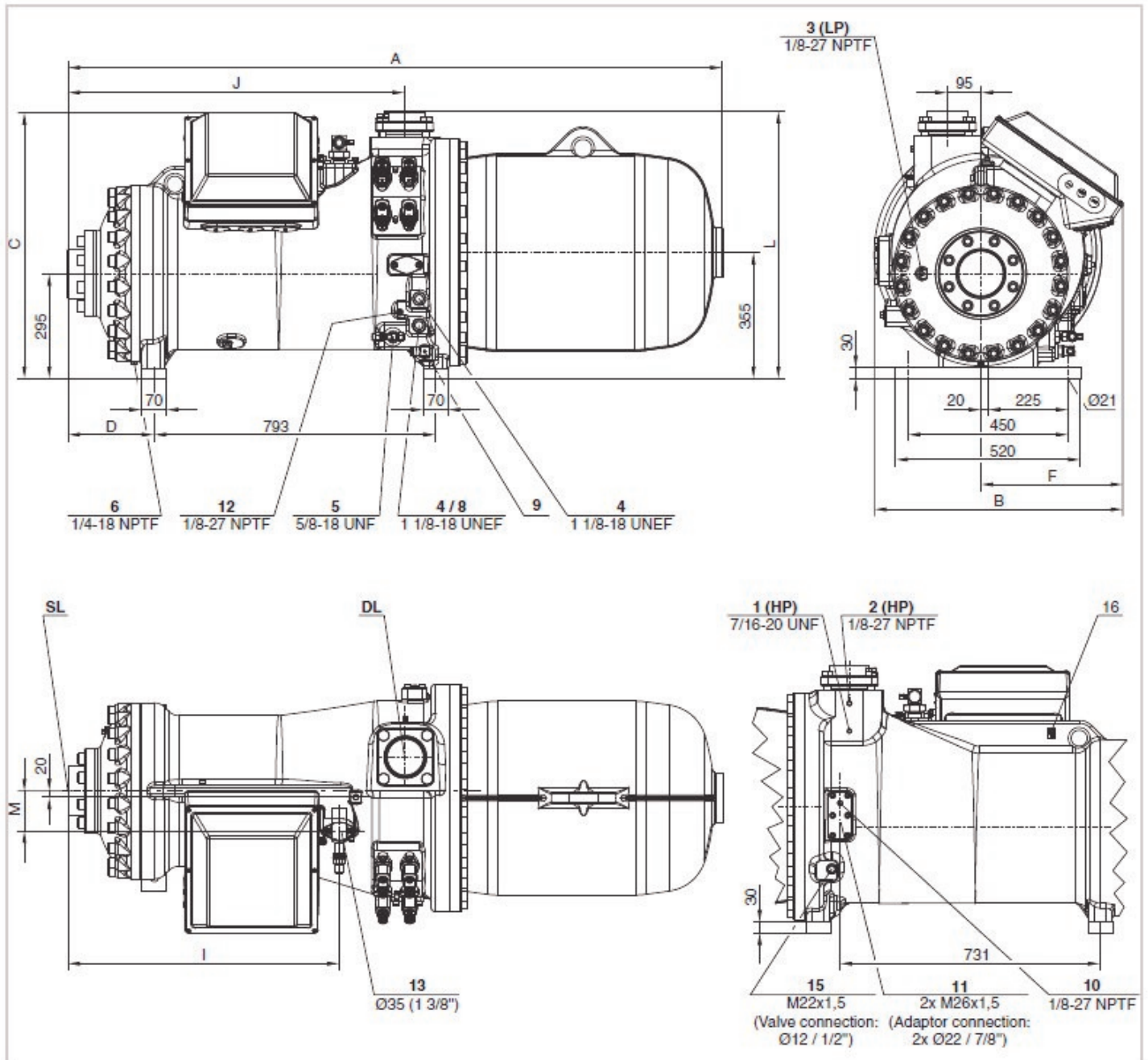

4 Compressor Data

4.5 CSW65 Outline Drawings

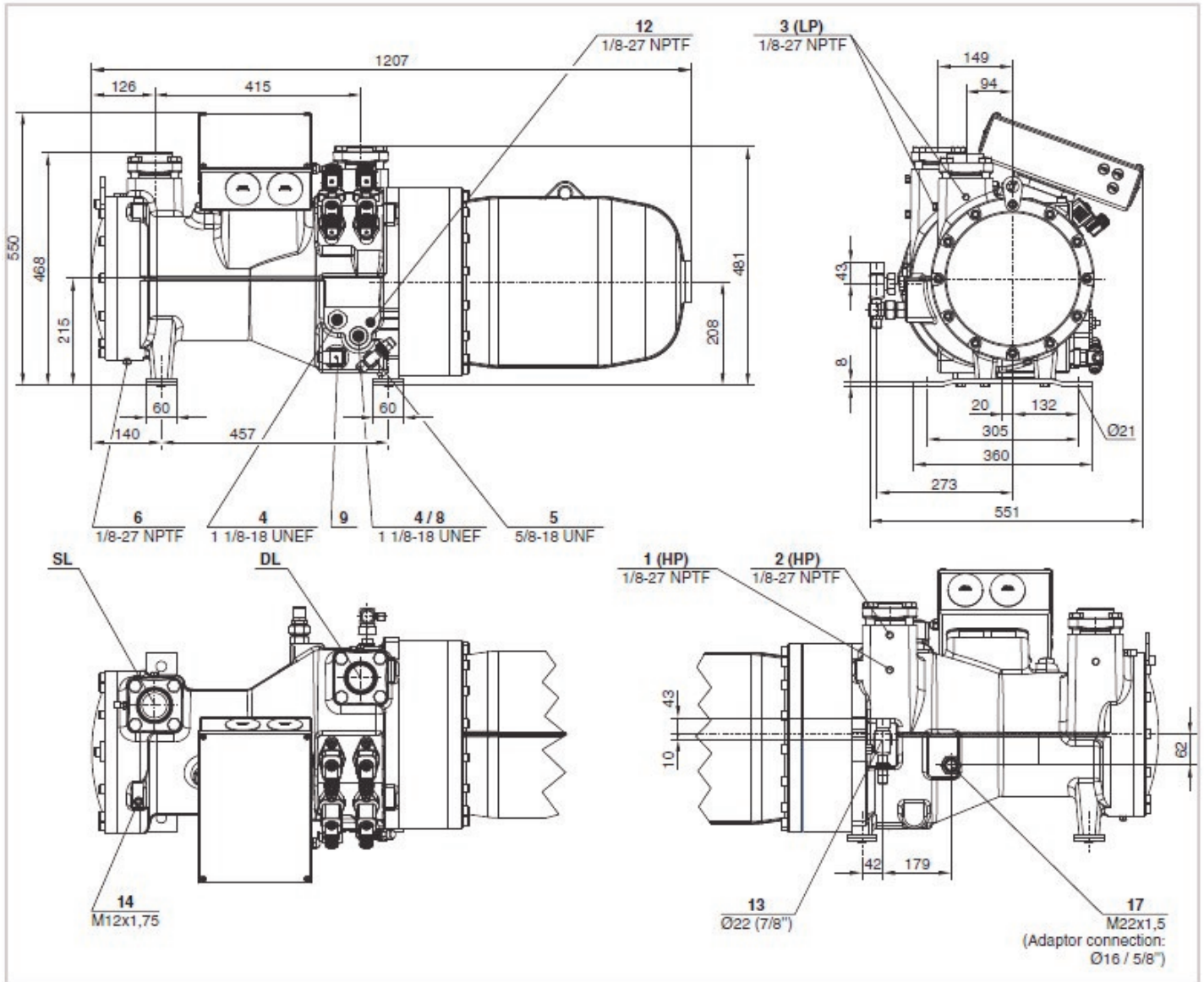

4.6 CSW75 Outline Drawings

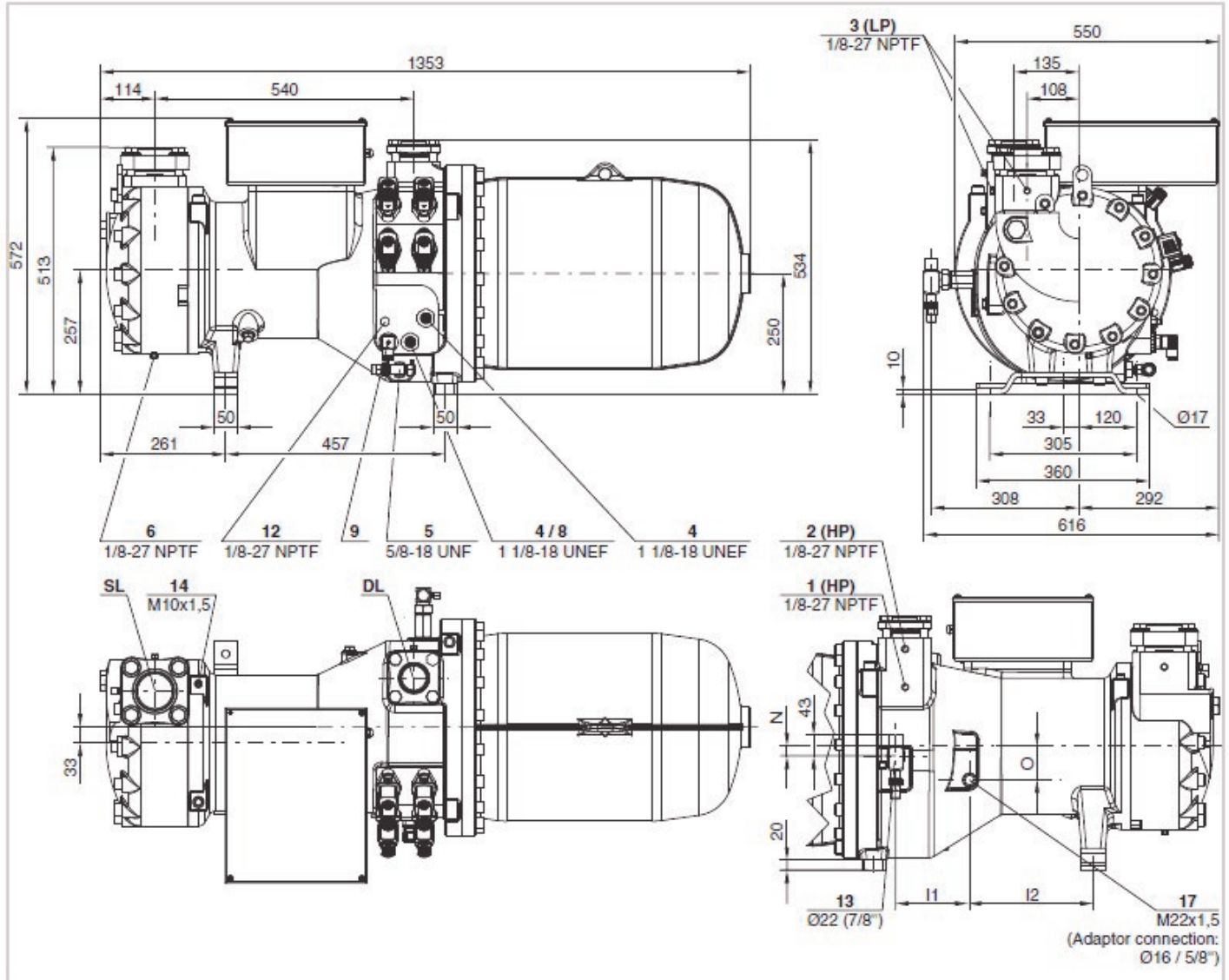

4 Compressor Data

4.7 CSW85 Outline Drawings

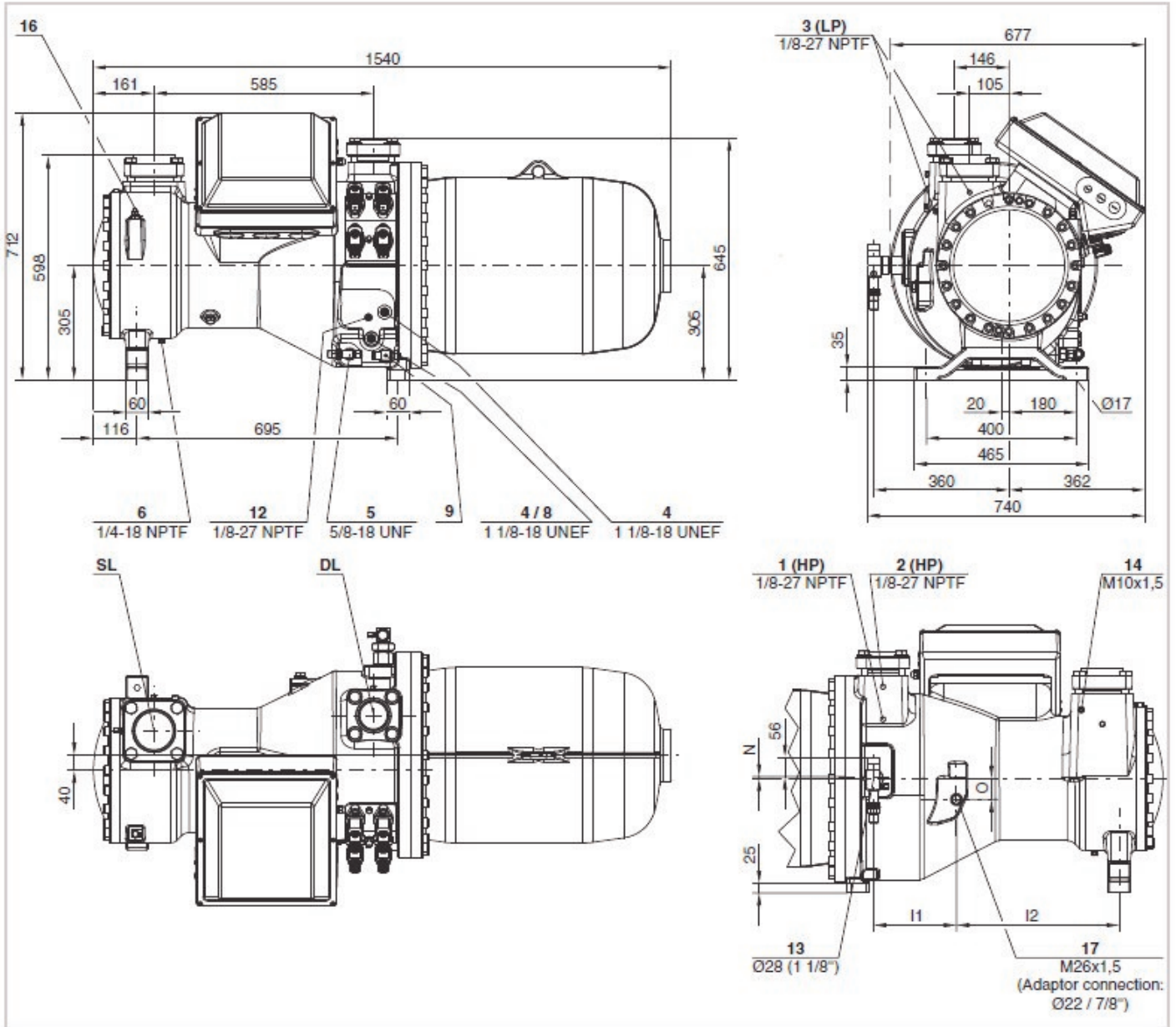

4.8 CSW95 Outline Drawings

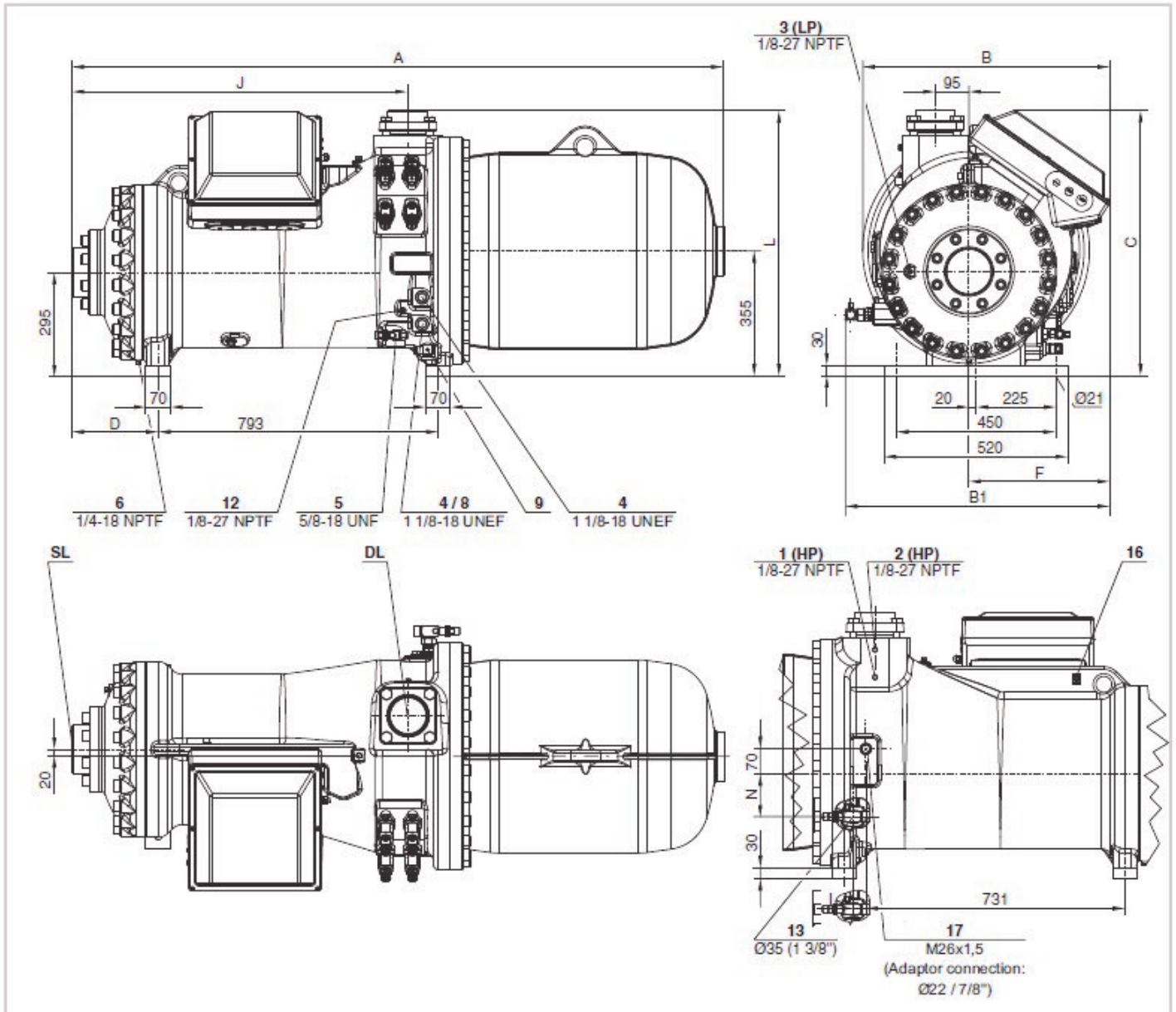

4 Compressor Data

4.9 CS Connection Positions

CSH Connection Positions

1	High pressure connection (HP)
2	Additional HP connection
3	Low pressure connection (LP)
4	Oil sight glass
5	Oil service valve (std) / connection for oil equalization (parallel operation)
6	Oil drain plug (motor housing)
8	Connection for opto-electrical oil level switch OLC-D1-S (optional)
9	Oil heater with sleeve (std)
10	Oil pressure connection
11	External oil cooler connections (adaptor with control valve optional)
12	Oil temperature sensor (PTC)
13	Economizer connection (ECO) (pulsation muffler w/ shut-off valve optional)
14	Threaded hole for pipe support (ECO or LI line)
15	Liquid injection connection (LI)
16	Grounding screw for housing
SL	Suction line
DL	Discharge line

CSW Connection Positions

1	High pressure connection (HP)
2	Additional HP connection
3	Low pressure connection (LP)
4	Oil sight glass
5	Oil service valve (std) / connection for oil equalization (parallel operation)
6	Oil drain plug (motor housing)
7	Oil charge connection - alternative use for pos. 8
8	Optical oil level switch
9	Oil heater with sleeve (std)
12	Oil temperature sensor (PTC)
13	Economizer connection (pulsation muffler w/ shut-off valve optional)
14	Threaded hole for pipe support (ECO line)
16	Grounding screw for housing
17	Connection for oil and gas return (for systems with flooded evaporator - adaptor optional)
SL	Suction line
DL	Discharge line

4.10 Compressor Technical Data CSH65 and 75 Compressor Data

2.6 CSH65, CSH75 Technical Data									Tube Connections	
Frame Size	Model Number	HP	Motor Ver-sion	CFM	CFH	CR*	Oil Charge (gal)	Weight (lbs)	DL (in.)	SL (in.)
1	CSH6553-35Y	35	2	97	5830	25 - 100%	2.5	692	1 5/8	2 1/8
1	CSH6553-50(Y)	50	1	97	5830	25 - 100%	2.5	710	1 5/8	2 1/8
1	CSH6563-40Y	40	2	121	7240	25 - 100%	2.6	692	1 5/8	2 1/8
1	CSH6563-60(Y)	60	1	121	7240	25 - 100%	2.6	710	1 5/8	2 1/8
1	CSH6583-50Y	50	2	139	8334	25 - 100%	4.0	805	2 1/8	2 5/8
1	CSH6593-60Y	60	2	157	9394	25 - 100%	4.0	805	2 1/8	2 5/8
2	CSH7553-50Y	50	2	140	8405	25 - 100%	4.0	1103	2 1/8	3/18
2	CSH7553-70(Y)	70	1	140	8405	25 - 100%	4.0	1136	2 1/8	3/18
2	CSH7563-60Y	60	2	161	9676	25 - 100%	4.0	1125	2 1/8	3/18
2	CSH7563-80(Y)	80	1	161	9676	25 - 100%	4.0	1147	2 1/8	3/18
2	CSH7573-70Y	70	2	183	10983	25 - 100%	4.0	1136	2 1/8	3/18
2	CSH7573-90(Y)	90	1	183	10983	25 - 100%	4.0	1169	2 1/8	3/18
2	CSH7583-80Y	80	2	210	12572	25 - 100%	4.0	1158	2 1/8	3/18
2	CSH7583-100Y	100	1	210	12572	25 - 100%	4.0	1213	2 1/8	3/18
2	CSH7593-90Y	90	2	239	14338	25 - 100%	4.0	1169	2 1/8	3/18
2	CSH7593-110Y	110	1	239	14338	25 - 100%	4.0	1235	2 1/8	3/18

4 Compressor Data

4.11 Compressor Technical Data CSH85 and 95 Compressor Data

2.7 CSH85, CSH95 Technical Data									Tube Connections	
Frame Size	Model Number	HP	Motor Ver-sion	CFM	CFH	CR*	Oil Charge (gal)	Weight (lbs)	DL (in.)	SL (in.)
3	CSH8553-80Y	80	2	224	13420	25 - 100%	5.8	1830	3 1/8	4 1/8
3	CSH8553-110(Y)	110	1	224	13420	25 - 100%	5.8	1852	3 1/8	4 1/8
3	CSH8563-90Y	90	2	255	15291	25 - 100%	5.8	1830	3 1/8	4 1/8
3	CSH8563-125(Y)	125	1	255	15291	25 - 100%	5.8	1874	3 1/8	4 1/8
3	CSH8573-110Y	110	2	291	17481	25 - 100%	5.8	1852	3 1/8	4 1/8
3	CSH8573-140(Y)	140	1	291	17481	25 - 100%	5.8	1896	3 1/8	4 1/8
3	CSH8583-125Y	125	2	334	20024	25 - 100%	5.0	1874	3 1/8	4 1/8
3	CSH8583-140Y	140	2	334	20024	25 - 100%	5.0	1874	3 1/8	4 1/8
3	CSH8593-140Y	140	2	380	22814	25 - 100%	5.0	1896	3 1/8	4 1/8
3	CSH8593-160Y	160	2	380	22814	25 - 100%	5.0	1874	3 1/8	4 1/8
4	CSH9553-180(Y)	180	1	380	22814	25 - 100%	7.9	2822	3 1/8	4 1/8
4	CSH9563-160Y	160	2	437	26204	25 - 100%	7.9	2800	3 1/8	4 1/8
4	CSH9563-210(Y)	210	1	437	26204	25 - 100%	7.9	2867	3 1/8	4 1/8
4	CSH9573-180Y	180	2	497	29841	25 - 100%	7.9	2822	3 1/8	4 1/8
4	CSH9573-240(Y)	240	1	497	29841	25 - 100%	7.9	2889	3 1/8	4 1/8
4	CSH9583-210Y	210	2	572	34326	25 - 100%	7.9	2933	4 1/8	5
4	CSH9583-280Y	280	1	572	34326	25 - 100%	7.9	3000	4 1/8	5
4	CSH9593-240Y	240	2	646	38776	25 - 100%	7.9	2977	4 1/8	5

4.12 Compressor Technical Data CSW Series Compressor Data

2.8 CSW65, CSW75 Technical Data									Tube Connections	
Frame Size	Model Number	HP	Motor Version	CFM	CFH	CR*	Oil Charge (gal)	Weight (lbs)	DL (in.)	SL (in.)
1	CSW6583-40Y	40	2	139	8334	25 - 100%	2.6	794	2 1/8	2 5/8
1	CSW6583-50(Y)	50	1	139	8334	25 - 100%	2.6	805	2 1/8	2 5/8
1	CSW6593-50Y	50	2	157	9394	25 - 100%	2.6	794	2 1/8	2 5/8
1	CSW6593-60(Y)	60	1	157	9394	25 - 100%	2.6	805	2 1/8	2 5/8
2	CSW7573-60Y	60	2	183	10983	25 - 100%	4.0	1136	2 5/8*	3/18
2	CSW7573-70(Y)	70	1	183	10983	25 - 100%	4.0	1147	2 5/8*	3/18
2	CSW7583-70Y	70	2	210	12572	25 - 100%	4.0	1158	2 5/8*	3/18
2	CSW7583-80(Y)	80	1	210	12572	25 - 100%	4.0	1169	2 5/8*	3/18
2	CSW7593-80Y	80	2	239	14338	25 - 100%	4.0	1169	2 5/8*	3/18
2	CSW7593-90(Y)	90	1	239	14338	25 - 100%	4.0	1180	2 5/8*	3/18

2.4 CSW85, CSW95 Technical Data									Tube Connections	
Frame Size	Model Number	HP	Motor Version	CFM	CFH	CR*	Oil Charge (gal)	Weight (lbs)	DL (in.)	SL (in.)
3	CSW8573-90Y	90	2	291	17481	25 - 100%	5.8	1852	3 1/8	4 1/8
3	CSW8573-110(Y)	110	1	291	17481	25 - 100%	5.8	1874	3 1/8	4 1/8
3	CSW8583-110Y	110	2	334	20024	25 - 100%	5.0	1874	3 1/8	4 1/8
3	CSW8583-125(Y)	125	1	334	20024	25 - 100%	5.0	1896	3 1/8	4 1/8
3	CSW8593-125Y	125	2	380	22814	25 - 100%	5.0	1918	3 1/8	4 1/8
3	CSW8593-140(Y)	140	1	380	22814	25 - 100%	5.0	11940	3 1/8	4 1/8
4	CSW9563-140Y	140	2	437	26204	25 - 100%	7.9	2800	4 1/8	4 1/8
4	CSW9573-160Y	160	2	497	29841	25 - 100%	7.9	2778	4 1/8	4 1/8
4	CSW9573-180(Y)	180	1	497	29841	25 - 100%	7.9	2844	4 1/8	4 1/8
4	CSW95783-180Y	180	2	572	34326	25 - 100%	7.9	2911	4 1/8	5
4	CSW9583-210(Y)	210	1	572	34326	25 - 100%	7.9	2977	4 1/8	5
4	CSW9593-210Y	210	2	646	38776	25 - 100%	7.9	3000	4 1/8	5

4 Compressor Data

4.13 CS Operating Parameters

Temperatures and Pressures

Parameter	Min°	Max°	Recommended
Motor Temp	--	210°F	--
Discharge Temp	SCT + 32°F (54°F w/R22/407C)	248°F	--
Oil Temp	130°F	250°F	140°F
Superheat	5°F	35°F	15°F
Eco Superheat	5°F	35°F	20°F
Pressure Diff	70psi	--	--

Electrical SE-E1/2 Module

Parameter	Trip	Reset	Ambient
Motor PTCs (T1 to T2)	≈ 11.4kΩ	≈ 2.95kΩ	300 - 500Ω

Parameter	Terminal Pins	min	max
Motor Windings (2PU, 4PU, 5PU)* (6 pin terminal) *jumper bars removed	1-7, 2-8, 3-9	.3Ω	2.0Ω
	Pin to ground	OPEN	

* Standard SE-E1 module must be replaced with SE-E2 for VFD and soft-starters

Variable Frequency Drives

Parameter	min	max
Speed range*	25Hz	60Hz

* Slider cannot be used with VFD. Compressor must run at 100%

5.1 CS Solenoid Location Layout

The Bitzer CS series of compressors can be applied in various configurations with No modification to the compressor required. Depending on the number of capacity solenoids used, the compressor can be applied as either 4 step capacity control (25, 50, 75 and 100% control), 25 to 100% Infinite capacity control where only 2 of the solenoids are used and even 3 Step capacity control where only 3 of the solenoids are used generally with a 50% minimum. By pulsing these solenoids back and forth, any part load condition can be achieved between 25% to 100% load (dependent on actual operating conditions).

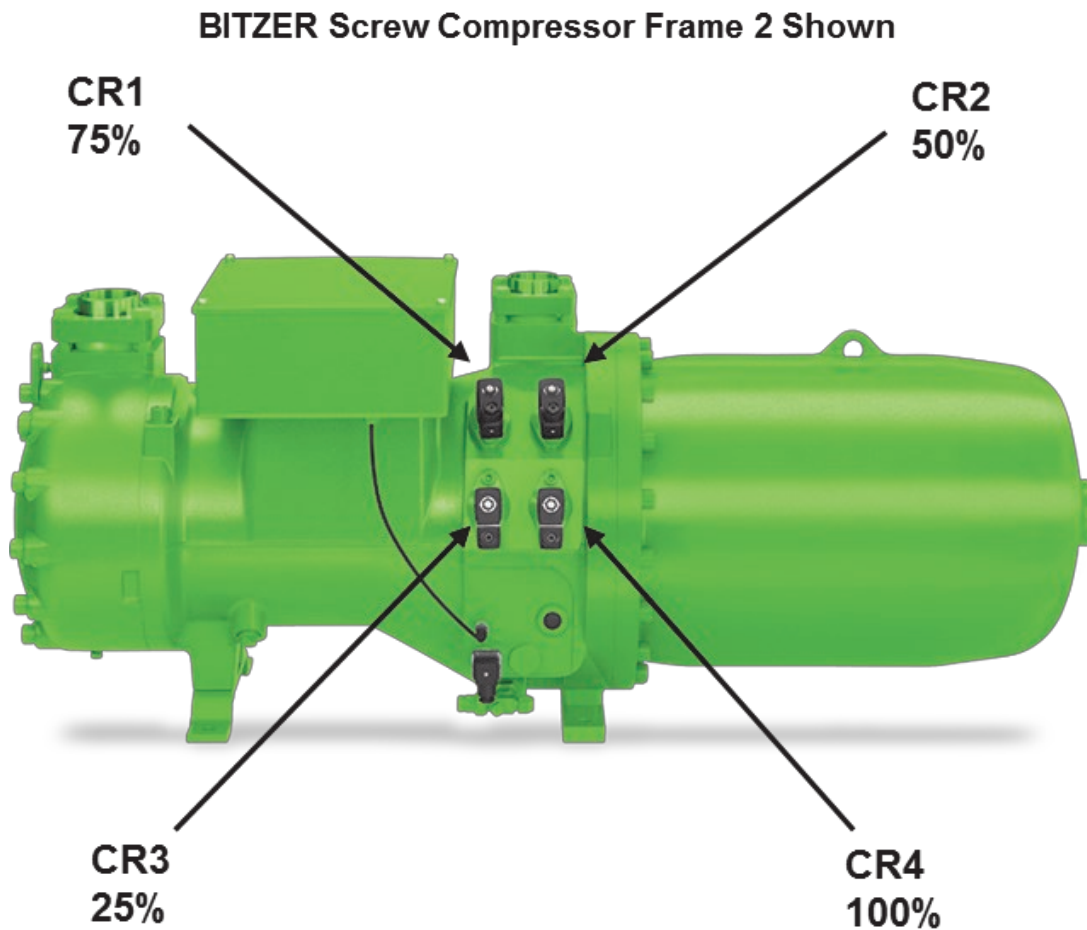

5 Solenoid Valves for Capacity Control

5.2 CS Solenoid Valves Operation

For the Bitzer Screw Compressor-4-Step Capacity Control				
Operation	Solenoid 1	Solenoid 2	Solenoid 3	Solenoid 4
Start/stop	De-energized	De-energized	Energized	Pulsing
Capacity 25%	De-energized	De-energized	Energized	Pulsing
Capacity 50%	De-energized	Energized	De-energized	Pulsing
Capacity 75%	Energized	De-energized	De-energized	Pulsing
Capacity 100%	De-energized	De-energized	De-energized	Energized

For the Bitzer Screw Compressor-Infinite Capacity Control 25-100%		
Operation	Solenoid 3	Solenoid 4
Start/stop	Energized	De-energized
Loading	De-energized	Pulsing
Unloading	Pulsing	De-energized

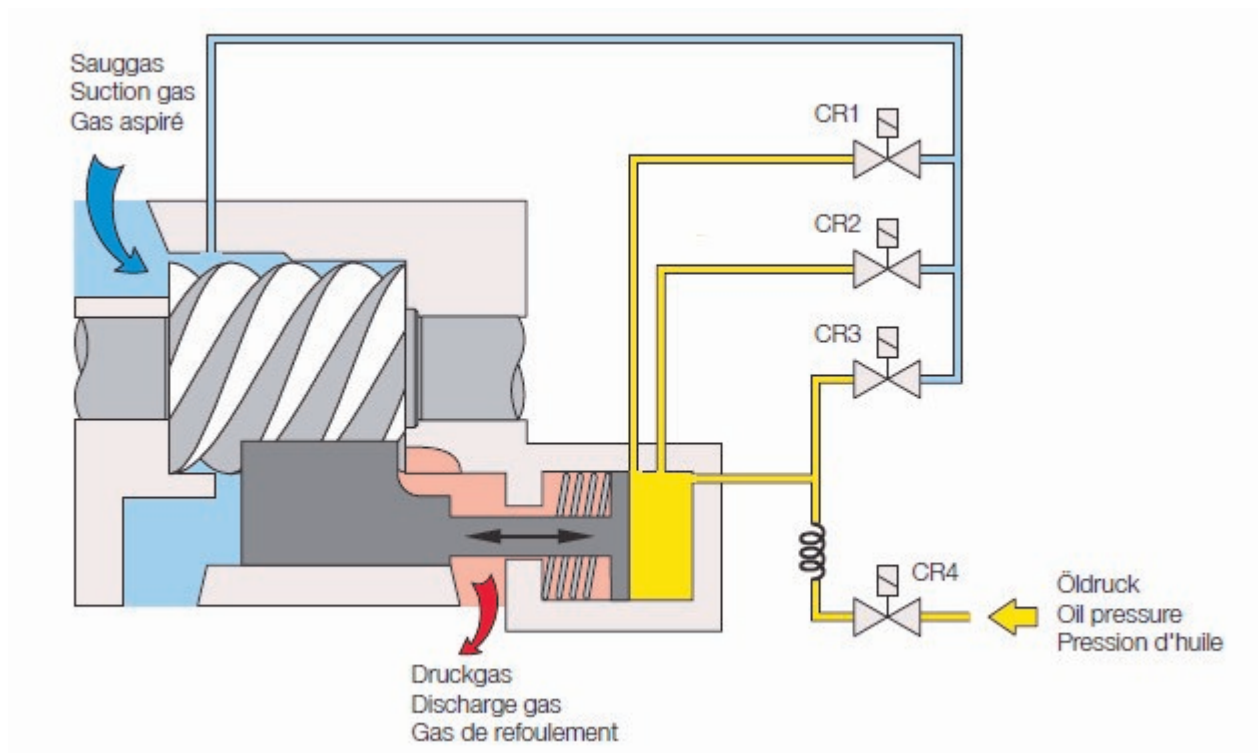

6.1 SE-E1 / SE-E2 Modules and Wiring

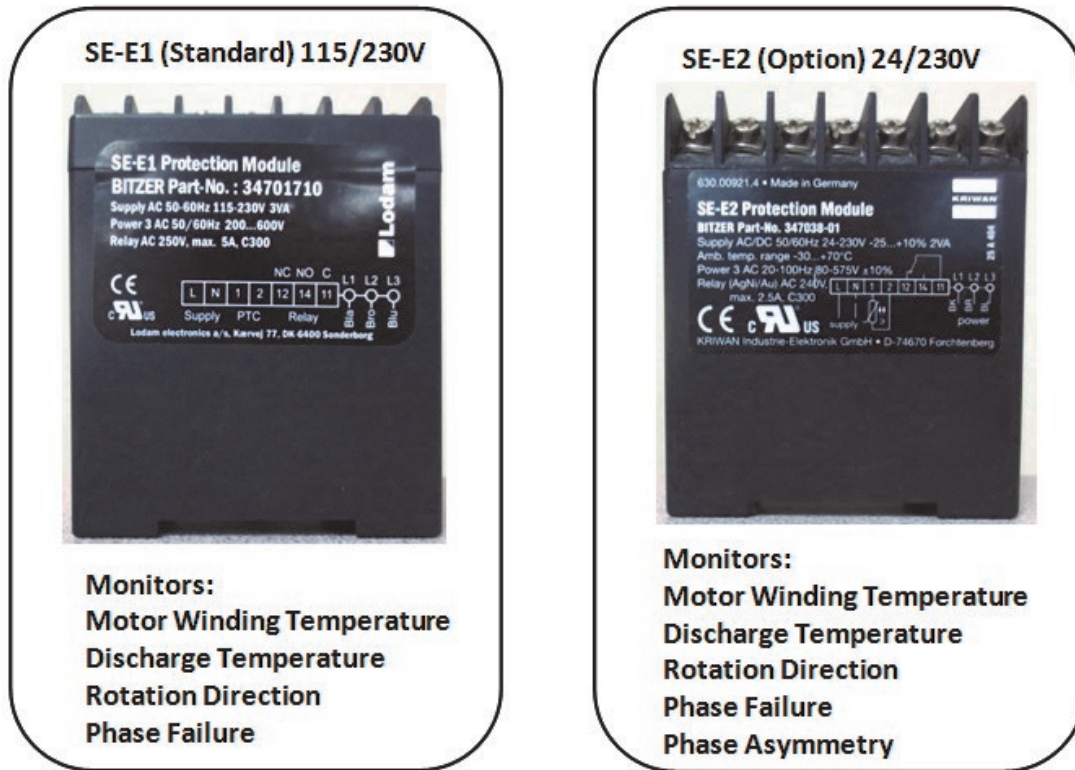

The SE-E1 is a dual voltage 110/220 volt standard.
 The SE-E2 is rated at 24/230 volt. This module must be used when utilizing a VFD or Softstarter.
 Each module is pre-wired inside of the terminal box.
 Even though the module is pre-wired, the connections should be checked for tightness.
 Module power and control circuit wiring must be connected.

Voltage / Phase Connections:

- L-1 (black) connected to L-1 spade connection on the terminal plate.
- L-2 (brown) connected to L-2 spade connection on the terminal plate.
- L-3 (blue) connected to L-3 spade connection on the terminal plate.

Note: Each lead is identified at the plug connector with the number markings (L1, L2, L3) and can also be found etched on the front of the module.

Motor Winding Temperature Connections:

- T-1 (brown) connected to number 1 on the module.
- T-2 (also brown) connected to position 5 on the connector strip.

Discharge Gas / Oil Temperature Sensor PTC120:

- Blue wire is connected to the opposite side of position 5 with the T-2 connection.
- Brown wire is connected to number 2 on the module.

The Compressor Control Circuit is wired through terminals 11 and 14 on the module.
 Terminal 12 can be utilized as a general compressor module fault output. It will be powered whenever the module trips.

6 Electrical Information

6.2 Wiring for Protection Devices

SE-E1, Oil Temperature Sensor and Oil Heater

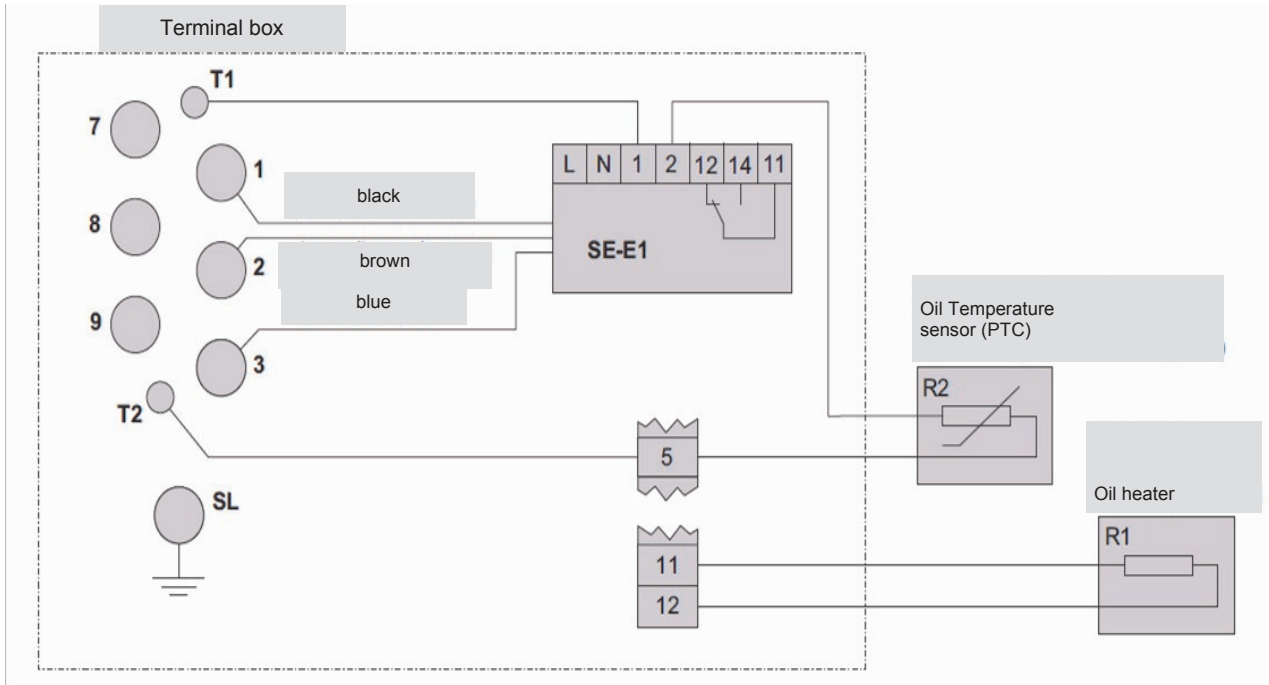

SE-E1 Monitoring functions	
Temperature	Immediate lock out at max motor or oil temperature
Rotation	Monitors for 5s at start up, immediate lock out in case of reverse rotation
Phase	6 min delay at start up if phase failure detected during first 5s Lock out if 3 phase failures within 18 minutes Lock out if 10 phase failures within 24 hours.

6.3 UL Motor Codes

Compressor Model	Motor Code	Nominal Voltage	Voltage Range	Motor Connection
CSH	4DU	460	414 - 506	Y/Δ
	5DU	575	517 - 633	Y/Δ
CSW	2PU	208 / 230	187 - 253	Y/YY
	4PU	460	414 - 506	Y/YY
	5PU	575	517 - 633	Y/YY

Legend:
D = Delta wiring
P = Part winding
U = UL approval
Y/YY = part winding option available
Note: All motor information listed for 60Hz

Motor Code Example:

CSW8573-90Y-2PU

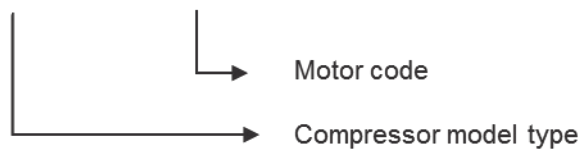

6 Electrical Information

6.4 Electrical Connection PWS Motors

4.4 Wiring Diagrams / Power Connection Part Winding Motors - 2PU, 4PU and 5PU

Motor Connection

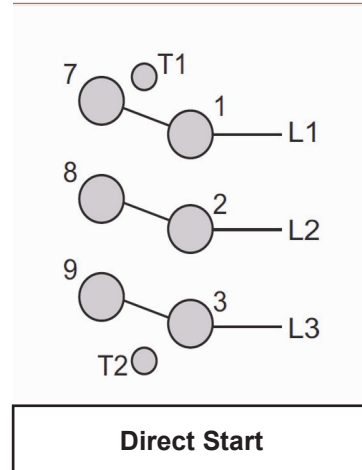
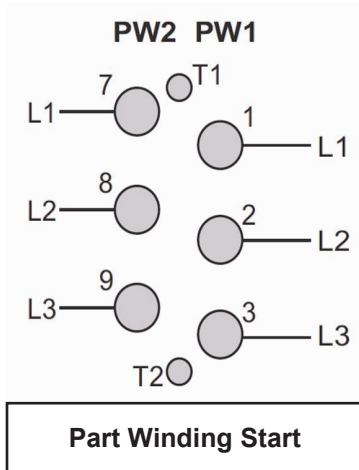

Wiring Schematic

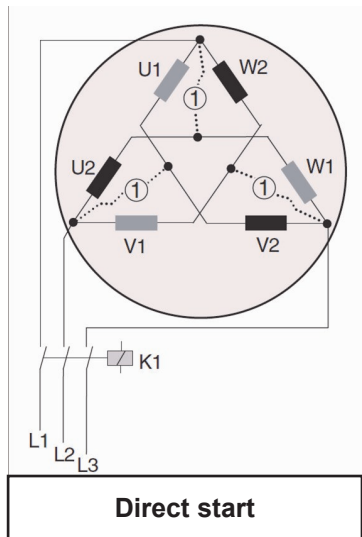
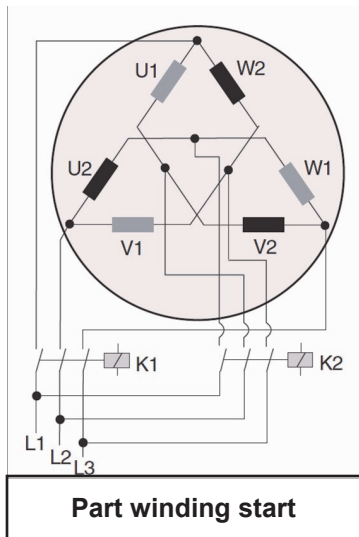

6.5 Electrical Connection Star Delta Motors 4DU and 5DU

Motor Connection

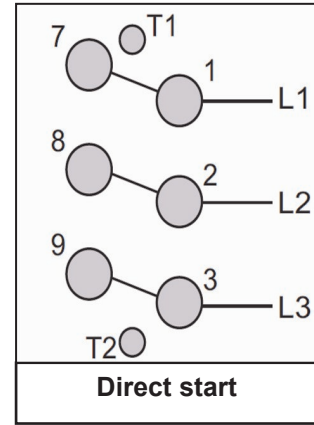
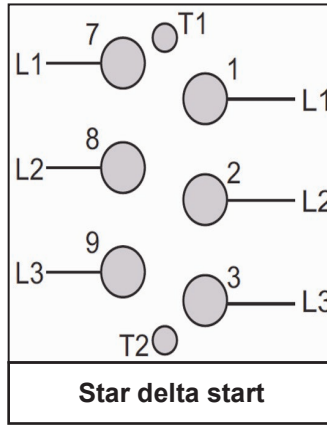
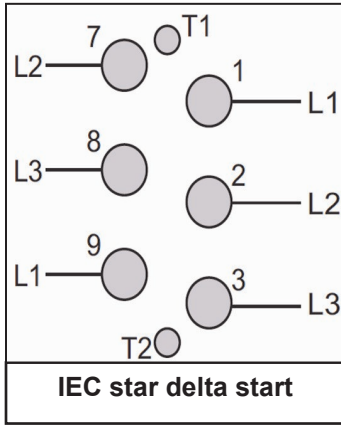

Wiring Schematic

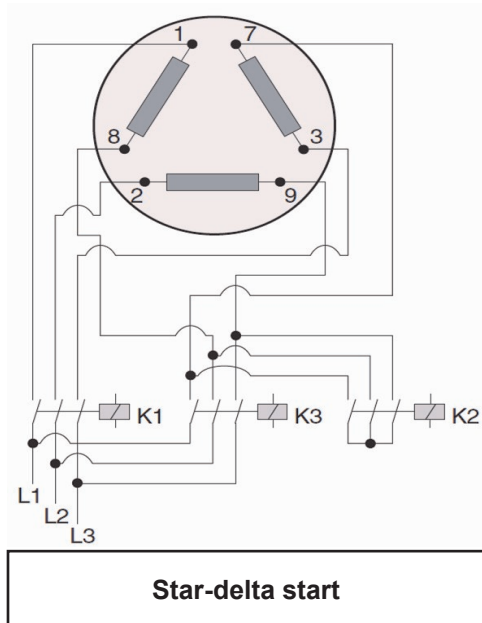

K1/K2 → K1/K3: 1 s

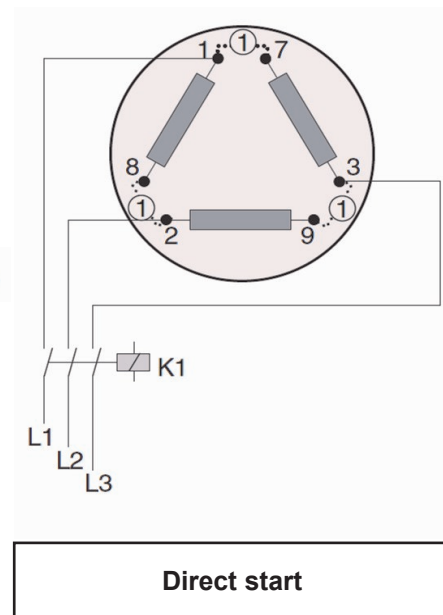

7 BITZER Screw Accessories and Options

7.1 Mechanical Oil Level Control (CSH.3)

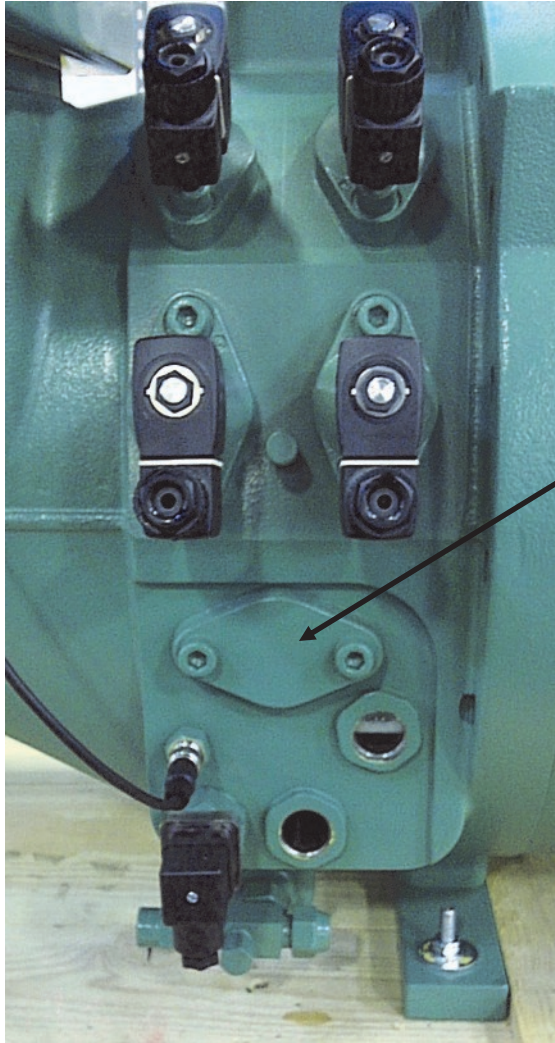

Model	Part Number
CS65	347403-05
CS75	347402-03
CS85	347403-03
CS95	347403-06

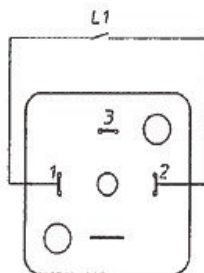

- / Operating temperature range: -14 to 248°F
- / Protection class: IP65
- / Contact function: Closing with rising level
- / Max. load (switch): 10VA, 250V, 0,5A

7.2 Optical Oil Level Control (CSW and CSH.3)

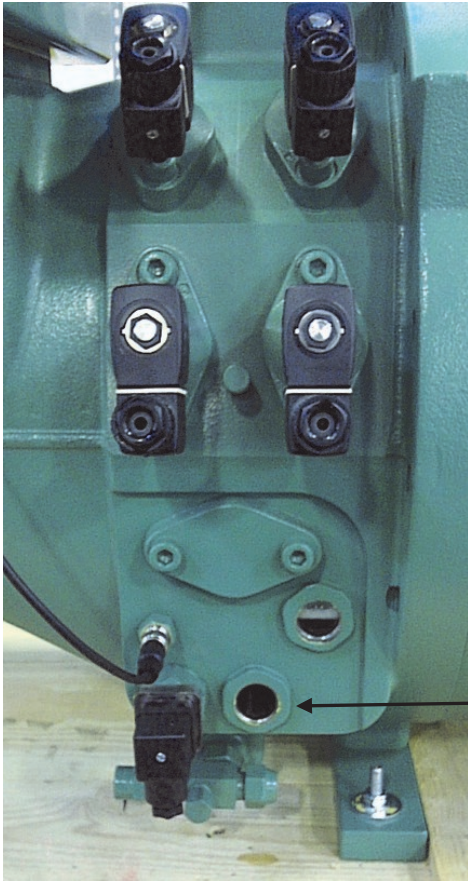

Part Number	Voltage
347962-02	115 volt
347962-01	220 volt
347962-03	24vac

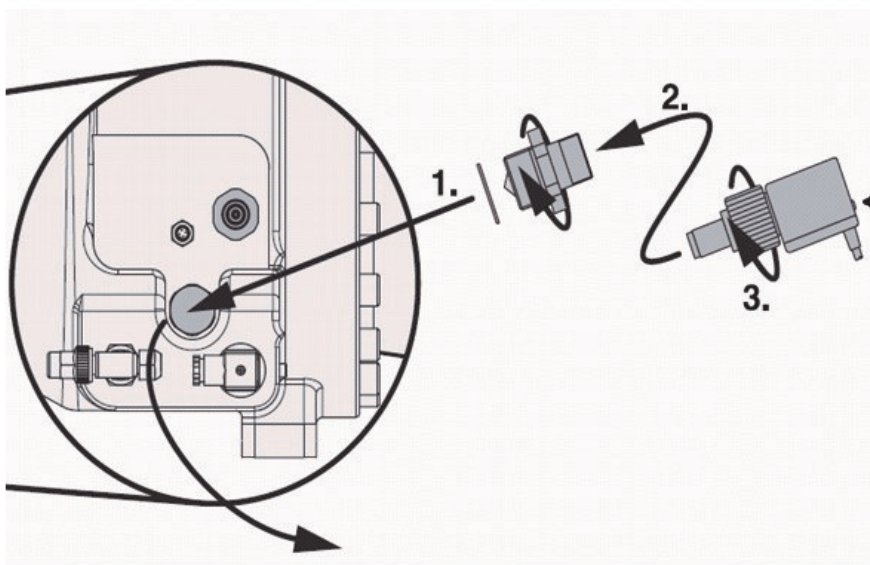

Status LED

- Operation
- Oil fault
- Blinking:
⇒ Electronic module not installed properly

- Reset: Interrupt power supply L/N for 5s minimum
- Maximum of 90 sec time delay

7 BITZER Screw Accessories and Options

7.3 CS65-75-85 Mounting Rails (999-0016-01)

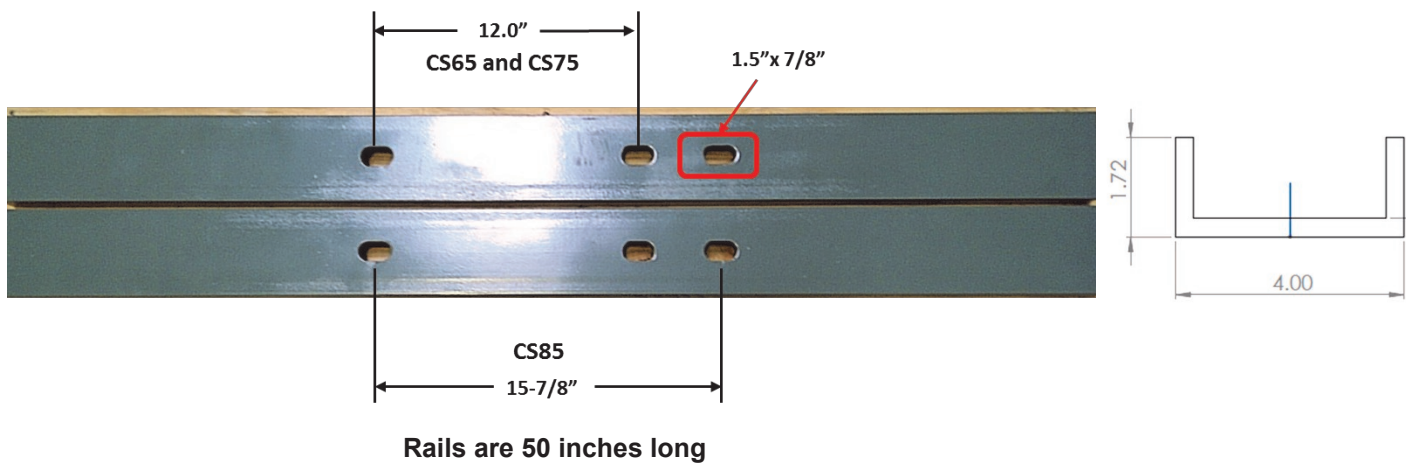

It is recommended to use vibration dampers with the rails.

Recommended Mounting

Bolt Sizes:

CS65 = 3/8"

CS75 = 5/8"

CS85 = 5/8"

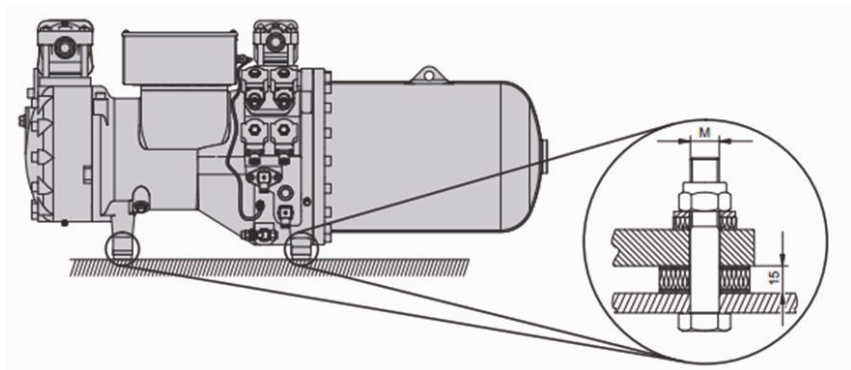

7.4 CSH.3 Series Liquid Injection (361332-10) and LI Controller (085-0164-17)

Compared to the CSW series, the CSH.3 models can be operated in areas of higher condensing and/or lower evaporating temperatures. In these areas additional cooling may be required. This can be achieved by Direct (LI) into the rotor profile area.

CSH.3 screws have a separate connection for liquid injection. This is located directly besides the oil separator flange. This connection leads directly into the discharge side profile area.



361332-10

085-0164-17

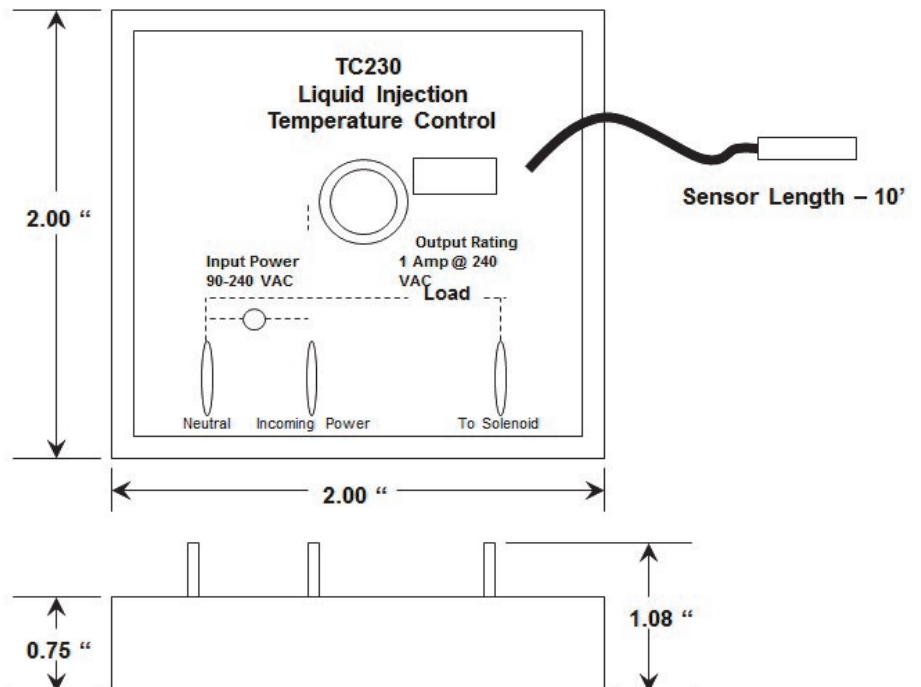
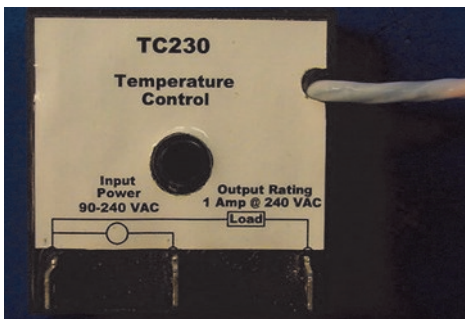

8 FuSheng SR Series to BITZER CS Series

8.1 Overview

Sizing Information:

For replacement compressor selection a CFH comparison of each compressor is given in section 2 and dimensional information is given in section 4.

Mechanical Information:

The suction and discharge connection sizes are different between the FuSheng and the BITZER CS compressors. Size information is given on page 42, section 8.5

The FuSheng SR-1, 2 and 3 screws have the suction and discharge connections located on the ends.

The FuSheng SR-4, 5, 6, and 7 connections are located on the top of the compressor.

The BITZER CS compressors have them located on the top of the compressor for the CS65, 75 and 85 series.

The suction valve connection is located on the end for the CSH9553-180 through the CSH9573-240.

The suction and discharge isolation valves, as well as the discharge check valve, can be removed from the existing piping on the FuSheng. The BITZER CS compressors are supplied with suction and discharge service valves and an internal check valve.

Wiring Information:

The FuSheng has a thermal motor protector where the control circuit is wired through terminals T1 & T2.

On the BITZER CS compressors the control circuit is wired through terminals 11 & 14 and module power is connected to L & N.

There is an additional connection on the BITZER CS protection module at terminal 12. This can be used to indicate a general compressor failure.

The reverse phase and high discharge temperature protection that was used for the FuSheng must be removed as this function is incorporated into the BITZER CS protection module.

Operational Information:

The loading and unloading between the compressors is very similar.

See section 8.3, Capacity Control.



FuSheng SR2(H) Series

SR = Screw Refrigerant

2 = Series Number

(H) = Air Cooled

8.2 Scope of Standard Delivery

Scope of Standard Delivery (as supplied by Manufacturer)	Bitzer CSH	FuSheng SR
Capacity control system : 4-Steps or Infinite Continuous (See Below)	No Modification Required	Δ 3 Step
25% to 100% Capacity Control	●	●
Conversion Kit Stepped to Stepless Control	Not Required	Δ
4 Step Capacity Control	●	●
Infinite Capacity Control	●	Δ
Solenoid coils for capacity control	●	Δ
Volume ratio Vi, Option Vi=2.2, 2.6, 3.0, 3.5	Built In	
Discharge Check Valve	● Internal	● External
Suction Coupling tube and/or Flange	N/A	●
Discharge Coupling tube and/or Flange	N/A	●
Suction Service Valve	●	Δ
Discharge Service Valve	●	Δ
Suction service valve location	Top	End
Discharge service valve location	Top	End or Top
Oil Charge	●	●
Electronic Module (Rotation)	●	Δ
Electronic Module (Temperature)	●	●
PTC100 type temperature sensor	N/A	N/A
PTC120 type temperature sensor	●	●
PT100 type motor temperature sensor	PTC Sensors	N/A
PTC110 type temperature sensor	N/A	●
Screw in Discharge temperature sensor	● (251F)	● (266F)
IP-54 Terminal box	●	
Crankcase oil heater	●	●
Compress chamber (Middle side) liquid inject port	●	Δ
Motor side (Low side) liquid inject port	Not Required	●
Economizer port	●	●
Oil cooling connection	●	●
Liquid injection oil cooling port	●	●
Oil drain valve	●	●
Oil level switch	Δ	Δ
Oil filter different pressure (ΔP) protector switch	Not Required	Not Required
Liquid injection expansion valve	N/A	Δ
Liquid injection solenoid valve	N/A	Δ
Safety Valve	● Internal	Δ
Position sensor (Capacity control)	N/A	N/A
Slide fit motor	●	No
Starting type PWS	●	No
Starting type Start Delta	Δ	●
Jumper bars for DOL starting	●	Δ
Rubber mounting pads	●	Δ
Oil Separator	Intregal	Intregal

● (Standard) Δ (Option) N/A Not Applicable

8 FuSheng SR Series to BITZER CS Series

8.3 Capacity Control

Please see section 5 for more BITZER solenoid valve information

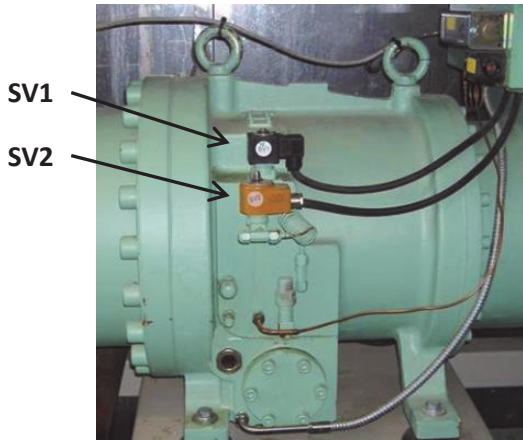

For the FuSheng Compressor Linear		
Operation	Solenoid 1	Solenoid 2
Start / Stop	On	Off
Loading	Off	Off
Unloading	On	Off
Holding	Off	On
For the Bitzer Screw Compressor Infinite		
Operation	Solenoid 3	Solenoid 4
Start / Stop	Energized	De-energized
Loading	De-energized	Pulsing
Unloading	Pulsing	De-energized

For the FuSheng 3 Step Capacity Control			
Operation	Solenoid 1 (SV0)	Solenoid 2 (SV1)	Solenoid 3 (SV3)
Start / Stop 25%	On	Off	Off
50%	Off	Off	On
75%	Off	On	Off
100%	Off	Off	Off

For the Bitzer Screw Compressor-4-Step Capacity Control				
Operation	Solenoid 1	Solenoid 2	Solenoid 3	Solenoid 4
Start/stop	De-energized	De-energized	Energized	Pulsing
Capacity 25%	De-energized	De-energized	Energized	Pulsing
Capacity 50%	De-energized	Energized	De-energized	Pulsing
Capacity 75%	Energized	De-energized	De-energized	Pulsing
Capacity 100%	De-energized	De-energized	De-energized	Energized

8.4 Module, Terminal Plate and Starting Types

In applications where reduced voltage starting is used the FuSheng will have a Star - Delta starter. This is different than the BITZER CS compressor, which uses part winding starting for the CS65, 75 and 85 series. The CS95 series utilize Star - Delta reduced voltage starting. Full voltage or direct on line starting is the same for both compressors.

The overload relay and the contactors must be checked for proper sizing.

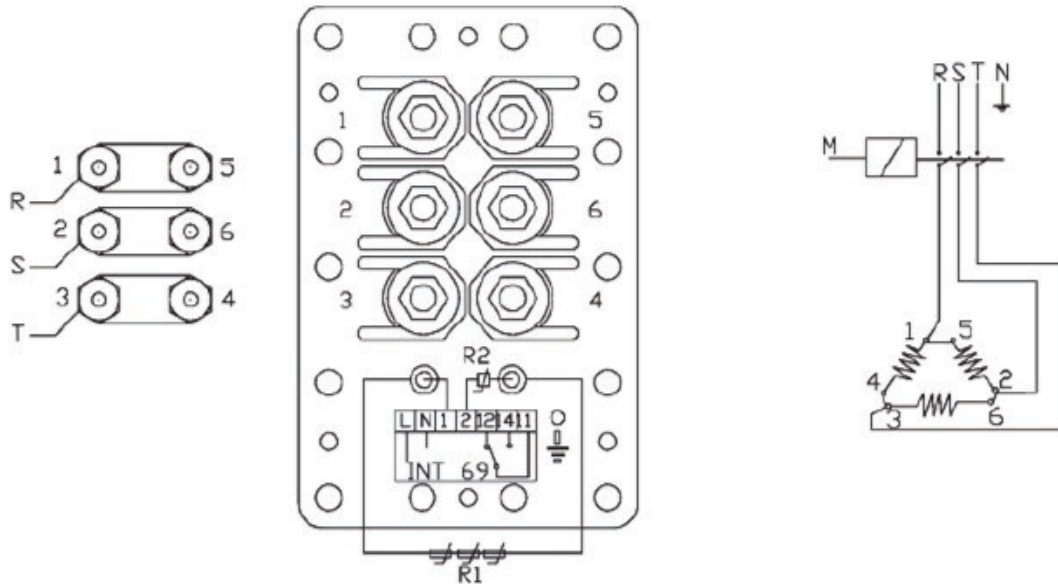

R1: Motor thermistor PTC	L/N: Phase/neutral 230V(115V) - 50/60Hz
R2: Discharge Temp thermistor PTC	11/14: Control circuit (NO)
R-S-T: Power supply	11/12: Control circuit (NC)
M,S: Start Contactors	1/2: Conn wires to thermistor(INT69)
M,D: Run contactors	

CS Terminal Box Wiring

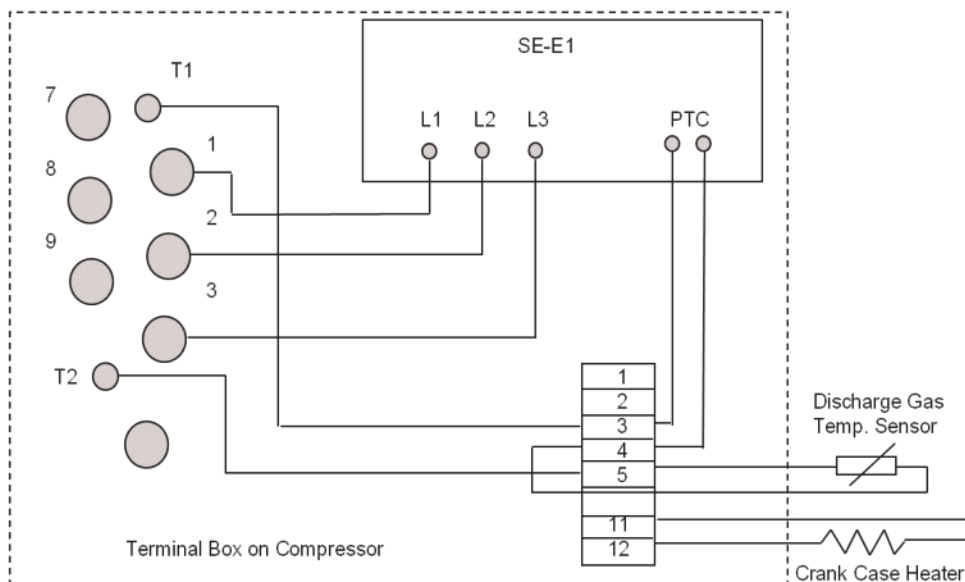

8 FuSheng SR Series to BITZER CS Series

8.5 Dimensions, Connections and Oil Types

FuSheng				
Model Number	L x W x H (in)	Weight (lb)	Suction Conn.	Discharge Conn.
SR1	57x18x23	924	2 5/8"	1 5/8"
SR2	61x19x23	1,144	2 5/8"	1 5/8"
SR3	61x19x23	1,166	2 5/8"	1 5/8"
SR4	68x32x33	1,980	4 1/8"	2 5/8"
SR5	70x32x33	2,046	4 1/8"	2 5/8"
SR6	71x32x34	2,420	4 1/8"	3 1/8"
SR7	73x32x34	2,530	4 1/8"	3 1/8"

BITZER Screw CS Compressor				
Model Number	L x W x H (in)	Weight (lb)	Suction Conn.	Discharge Conn.
CSH6553-50	44x22x22	716	2 1/8"	1 5/8"
CSH6563-60	44x22x22	716	2 1/8"	1 5/8"
CSH7553-70	53x22x24	1,076	3 1/8"	2 1/8"
CSH7563-80	53x22x24	1,085	3 1/8"	2 1/8"
CSH7573-90	53x22x24	1,103	3 1/8"	2 1/8"
CSH8553-110	61x28x29	1,753	4 1/8"	3 1/8"
CSH8563-125	61x28x29	1,766	4 1/8"	3 1/8"
CSH8573-140	61x28x29	1,788	4 1/8"	3 1/8"
CSH9553-180	72x28x34	2,734	4 1/8"	3 1/8"
CSH9563-210	72x28x34	2,778	4 1/8"	3 1/8"
CSH9573-240	72x28x34	2,800	4 1/8"	3 1/8"

Oil Types			
FuSheng	SR Series	R22 Oil	CPI4214-320
FuSheng	SR Series	R22 Oil	CP-4214-150
FuSheng	SR Series	R22 Oil	Suniso 4GSD
FuSheng	SR Series	R22 Oil	Suniso 5GSD
BITZER	CSH Series	R22 Oil	CPI4214-320

8.6 Compressor Conversion Pictures

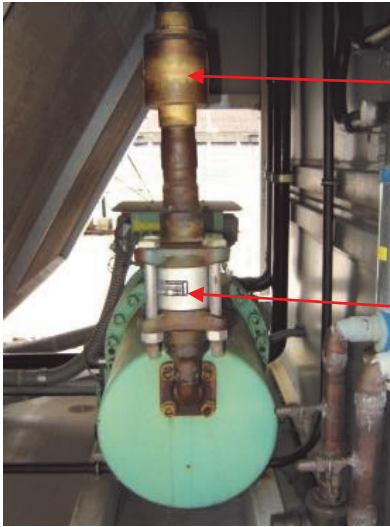

Remove FuSheng External Discharge Service Valve

Remove FuSheng External Check Valve



8 FuSheng SR Series to BITZER CS Series

8.7 CFH and Motor Horsepower Ratings

Model Number	CFH Displ 60Hz	Motor HP
CSH6553-50	5830	50
CSH6563-60	7244	60
CSH7553-70	8410	70
CSH7563-80	9682	80
CSH7573-90	10989	90
CSH7583-100	12572	100
CSH7593-110	14338	110
CSH8553-110	13428	110
CSH8563-125	15300	125
CSH8573-140	17491	140
CSH9553-180	22802	180
CSH9563-210	26212	210
CSH9573-240	29835	240
CSH9583-280	34310	280
CSH9593-300	38783	300

Model Number	CFH Displ 60Hz	Motor HP
SR1	6144	60
SR2	7768	72
SR3	9357	84
SR434	12323	115
SR4	15325	150
SR5	18326	175
SR561	20974	175
SR6	23587	240
SR7	29731	270
SR8	35239	320

9.1 Overview

Sizing Information:

For replacement compressor selection a CFH comparison of each compressor is given in section 2 and dimensional information is given in section 4.

Mechanical Information:

The suction and discharge connections are different between the Hanbell RC and the Bitzer compressors.

The Hanbell RC100B thru 580B and RC620B have the suction connection located on the end of the motor cover and the discharge connection located on the top.

The Hanbell RC610B thru 1520B has the suction and discharge connections located on the top of the compressor. The standard deliveries for the above models have suction and discharge flanges included. Service valves are supplied as an option.

Models RC1090B thru 1520B are recommended to be installed with 6" pipe on the discharge connection.

All Hanbell RC2 models are supplied with an option for external discharge valves.

The Bitzer compressors are supplied, as standard, with service valves which are located on the top for the CSH6553-50 through the CSH8573-140. The suction valve connection is located on the end for the CSH9553-180 through the CSH9573-240. The connection sizes are also different and the size information is supplied.

All BITZER CS compressors are supplied, as standard, with an internal discharge check valve which is located under the discharge service valve.

The weights of the compressors are similar and listed for comparison.

Wiring Information:

The control wiring for these compressors also has some differences.

The standard module included with the Hanbell RC series is the INT69.

This module does not have phase protection.

Optional modules include the INT69Y and INT69HBY which have phase protection.

All three modules have power connected to L and N.

The INT69 has the control circuit connected to 11 and 14 where the optional modules have the control circuit wired thru M1 and M2.

The INT69 has the motor winding sensors and discharge gas temperature sensor wired in series to 1 and 2.

The optional modules have these wired via S1 and S2.

The Bitzer CSH and CSW series utilizes a SE-E1 electronic module as standard.

The SE-E1 is a dual voltage 110/220 volt with other voltages available.

The control circuit is wired through terminals 11 & 14 and module power is connected to L & N.

The oil temperature sensor and motor winding sensors (T-1 and T-2) are pre-wired to the module.

The SE-E1 provides phase protection and is connected to L1, 2 and 3.

There is an additional connection on the SE-E1 electronic module at terminal 12. This can be used to indicate a general compressor fault.

See section 6 for an overview of the SE-E1 module.

9 Hanbell RC Series to BITZER CS Series

9.2 Scope of Standard Delivery

Scope of Standard Delivery (as supplied by Manufacturer)	Bitzer CSH	Hanbell RC
Capacity control system : 4-Steps or Infinite Continuous (See Below)	No Modification Req	Δ
25% to 100% Capacity Control	●	
Conversion Kit Stepped to Stepless Control	Not Required	Δ
4 Step Capacity Control	●	Δ
Infinite Capacity Control	●	Δ
Solenoid coils for capacity control	●	Δ
Volume ratio Vi, Option Vi=2.2, 2.6, 3.0, 3.5	Built In	Δ
Discharge Check Valve	● Internal	Δ External
Suction Coupling tube and/or Flange	N/A	●
Discharge Coupling tube and/or Flange	N/A	●
Suction Service Valve	●	Δ
Discharge Service Valve	●	Δ
Suction service valve location	Top	End
Discharge service valve location	Top	Top
Oil Charge	●	Δ
Electronic Module (Rotation)	●	Δ
Electronic Module (Temperature)	●	●
PTC100 type temperature sensor	N/A	●
PTC120 type temperature sensor	●	N/A
PT100 type motor temperature sensor	PTC Sensors	●
PTC110 type temperature sensor	N/A	N/A
Screw in Discharge temperature sensor	● (251F)	● (212F)
IP-54 Terminal box	●	●
Crankcase oil heater	●	●
Compress chamber (Middle side) liquid inject port	●	Δ
Motor side (Low side) liquid inject port	Not Required	Δ
Economizer port	●	●
Oil cooling connection	●	●
Liquid injection oil cooling port	●	●
Oil drain valve	●	●
Oil level switch	Δ	Δ
Oil filter different pressure (ΔP) protector switch	Not Required	Δ
Liquid injection expansion valve	N/A	Δ
Liquid injection solenoid valve	N/A	Δ
Safety Valve	● Internal	Δ
Position sensor (Capacity control)	N/A	Δ
Slide fit motor	●	No
Starting type PWS	●	No
Starting type Start Delta	Δ	●
Jumper bars for DOL starting	●	Δ
Rubber mounting pads	●	Δ
Oil Separator	Intregal	Intregal
● (Standard) Δ (Option) N/A Not Applicable		

9.3 Motor Horsepower Ratings

Model	Motor HP
RC2-100B	38
RC2-140B	50
RC2-170B	63
RC2-180B	66
RC2-200B	70
RC2-230B	81
RC2-260B	90
RC2-300B	107
RC2-310B	110
RC2-320B	114
RC2-340B	121
RC2-370B	130
RC2-410B	146
RC2-470B	170
RC2-510B	183
RC2-550B	195
RC2-580B	210
RC2-610B	214
RC2-620B	220
RC2-710B	250
RC2-790B	276
RC2-830B	290
RC2-930B	334
RC2-1020B	360
RC2-1090B	402

Nominal Horsepower (HP):
All above models nominal HP
ratings are not equal to the
maximum compressor HP

Model	Motor HP
CSH6553-50	50
CSH6563-60	60
CSH7553-70	70
CSH7563-80	80
CSH7573-90	90
CSH7583-100	100
CSH7593-110	110
CSH8553-110	110
CSH8563-125	125
CSH8573-140	140
CSH9553-180	180
CSH9563-210	210
CSH9573-240	240
CSH9583-280	280
CSH9593-300	300

Model	Motor HP
CSW6583-50	50
CSW6593-60	60
CSW7573-70	70
CSW7583-80	80
CSW7593-90	90
CSW8573-110	110
CSW8583-125	125
CSW8593-140	140
CSW9563-160	160
CSW9573-180	180
CSW9583-210	210
CSW9593-240	240
CSW95103-280	280

9 Hanbell RC Series to BITZER CS Series

9.4 Model Number Nomenclature

See section 1 for the BITZER CS series model number nomenclature.

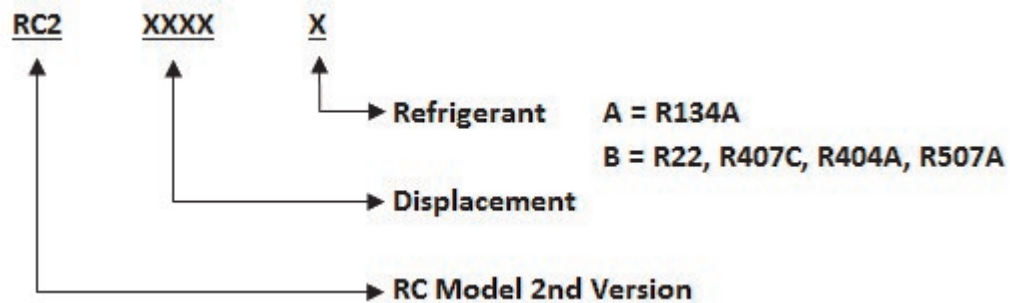

New Model	Old Model
RC2-100B	RC10
RC2-140B	RC11
RC2-170B	RC12
RC2-180B	N/A
RC2-200B	RC13
RC2-230B	N/A
RC2-260B	RC14
RC2-300B	RC15
RC2-310B	N/A
RC2-320B	RC15L
RC2-340B	N/A
RC2-370B	N/A
RC2-410B	RC16
RC2-470B	RC17
RC2-510B	N/A
RC2-550B	RC18
RC2-580B	N/A
RC2-610B	RC19
RC2-620B	N/A
RC2-710B	N/A
RC2-790B	RC20
RC2-830B	RC21
RC2-930B	N/A
RC2-1020B	N/A
RC2-1090B	RC22

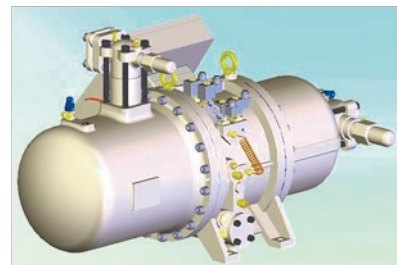

9.5 Modules and Wiring

The control wiring for these compressors also has some differences.

The standard module included with the Hanbell RC series is the INT69. This module does not have phase protection.

Optional modules include the INT69Y and INT69HBY which have phase protection.

All three modules have power connected to L and N.

The INT69 has the control circuit connected to 11 and 14 where the optional modules have the control circuit wired thru M1 and M2.

The INT69 has the motor winding sensors and discharge gas temperature sensor wired in series to 1 and 2.

The optional modules have these wired via S1 and S2.

The Bitzer CSH and CSW series utilizes a SE-E1 electronic module as standard.

See section 6 for an overview of the SE-E1 module.

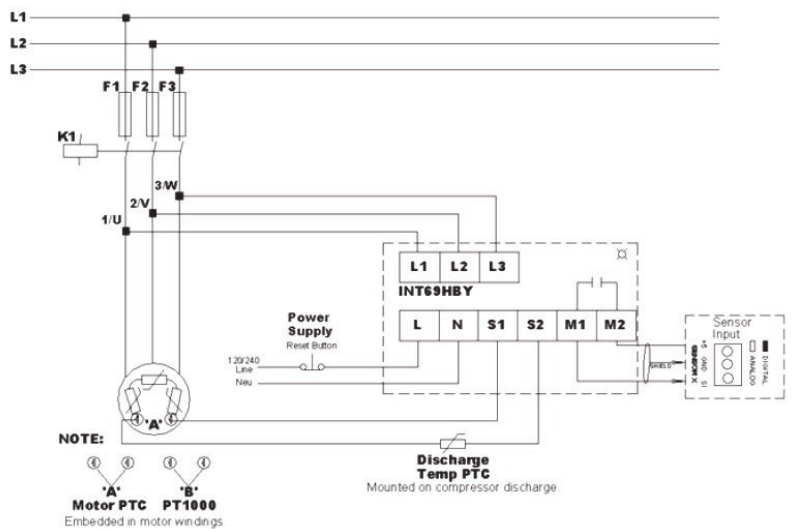
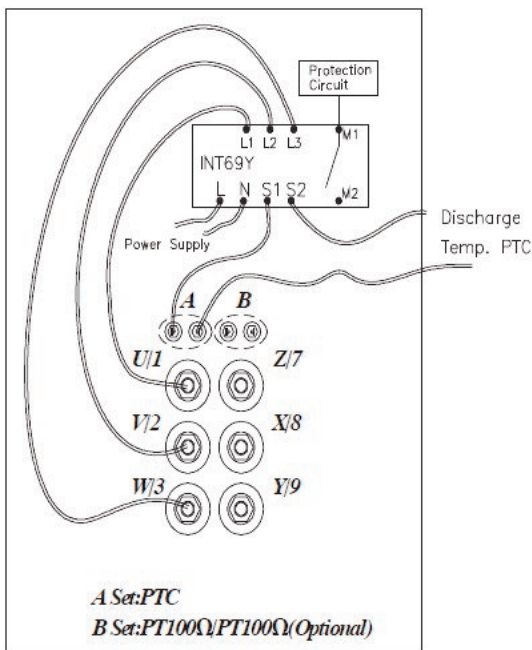

INT69HBY Connection

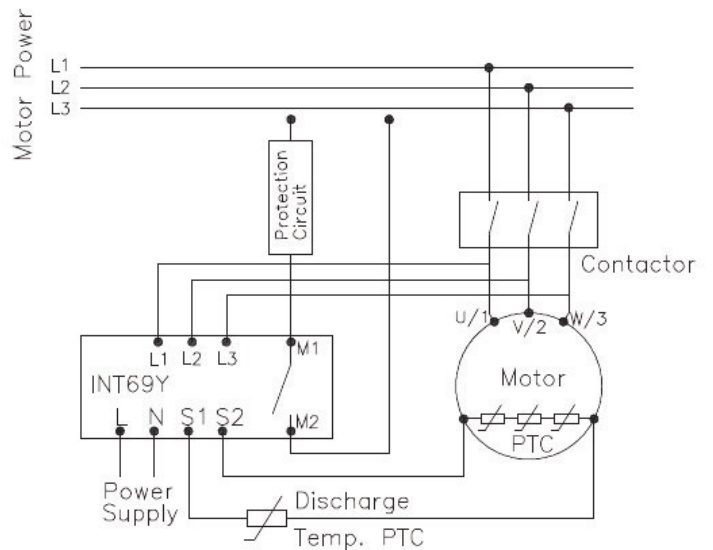
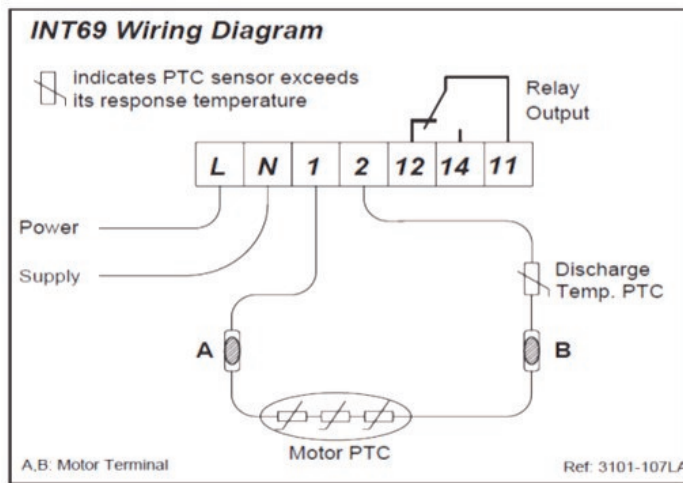

9 Hanbell RC Series to BITZER CS Series

9.5 Modules and Wiring (Continued)

INT69HBY Motor Protector

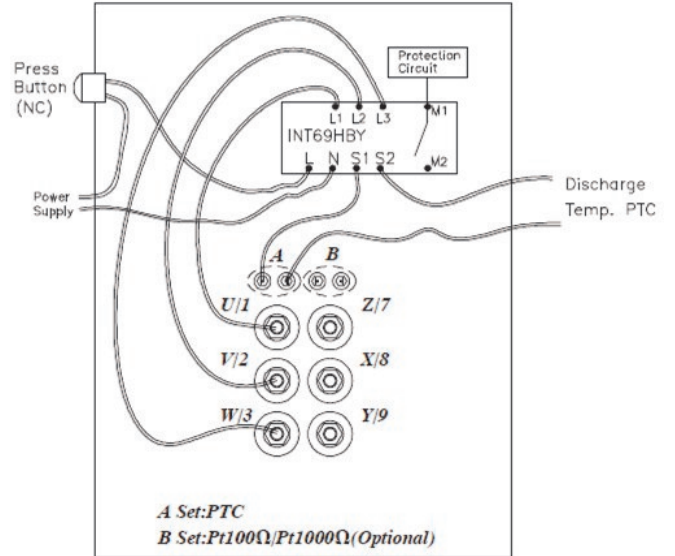
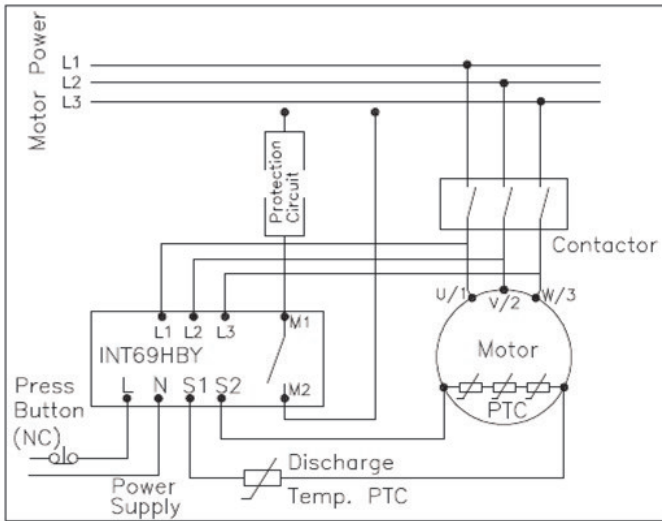

SE-E1 typical wiring inside of the CS terminal box:

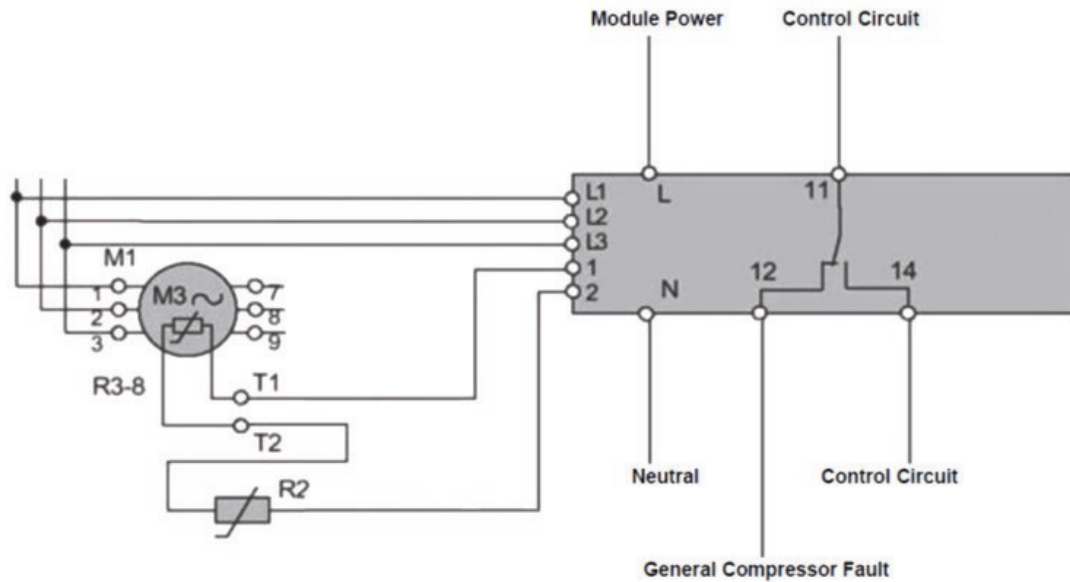

9.6 Starting Types

Typical Wiring Diagram for "XL" or "DOL" Starting Sequence

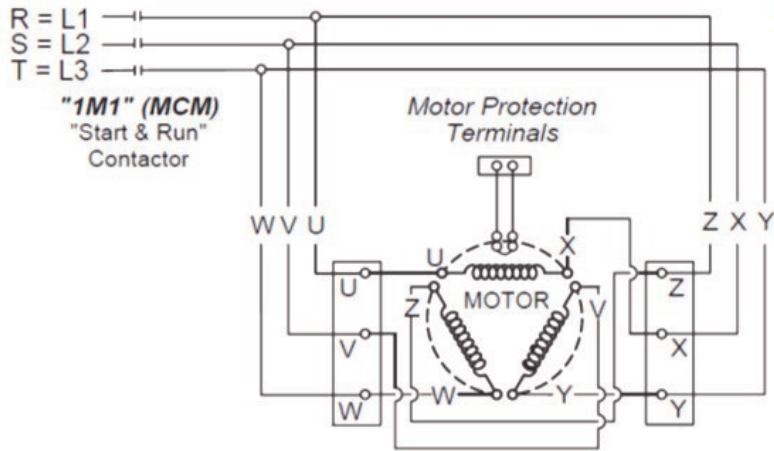

- "XL" (Across-the-Line) or "DOL" (Direct on Line) Starting Sequence
1. XL (DOL) Starting ~ 1M1 Closes and U, V, W plus Z, X, and Y are all energized simultaneously.
 2. XL (DOL) Starting Method is a single step starting, with a single contactor.
 3. The compressor terminals must be barred, "U-Z", "V-X", & "W-Y", for a three terminal wiring system as shown.

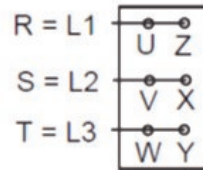

SRM-10713

There are two types of terminal cover plates used on the Hanbell RC2 series compressors (models RC2-100-930 A/B): one is with 6 power bolts and one set of sensor terminals (PTC) and the other is with 6 power bolts and 2 sets of sensor terminals (PTC & PT100 or PT1000). Hanbell will provide only one type of terminal cover which is the 6 power bolts and 2 sets of sensor terminals from 2012.

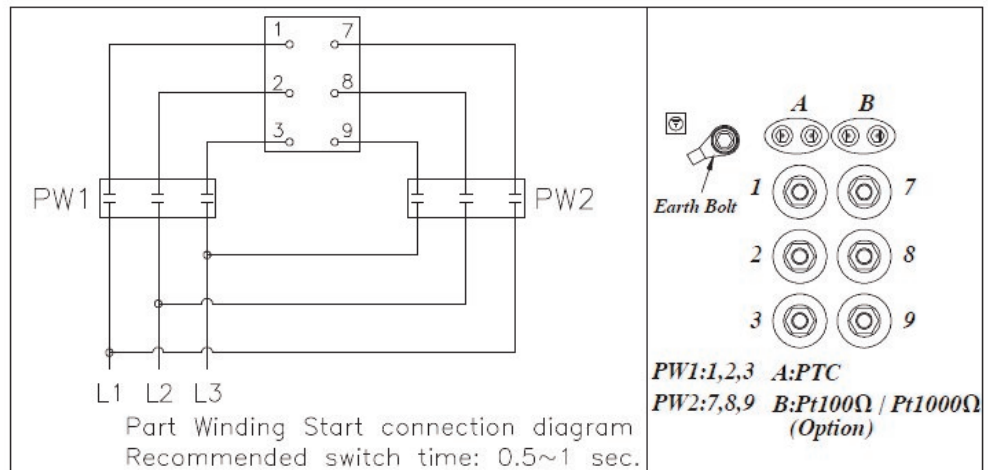
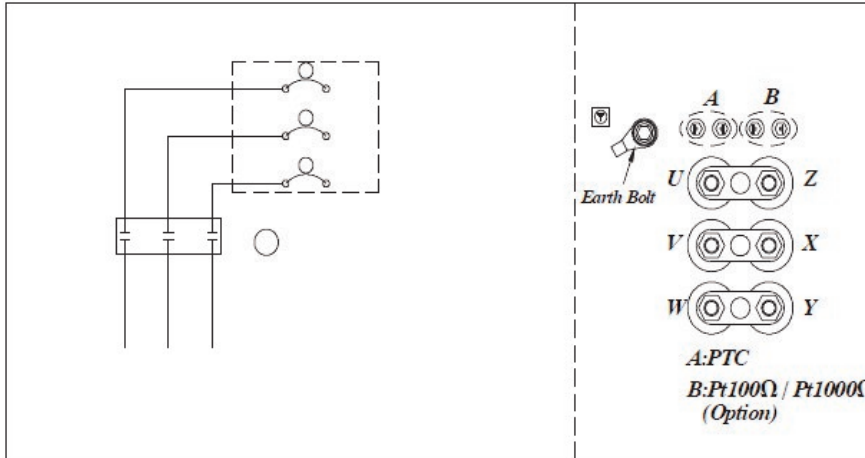

9 Hanbell RC Series to BITZER CS Series

9.7 Capacity Control

Please see section 5 for more BITZER solenoid valve information

The loading and unloading of the compressors are also different. Depending on the Hanbell model with the type of capacity control provided, the control schemes will be different.

Charts are provided detailing the types of capacity control.

Depending on the model, capacity will range from a minimum of 25, 30 or 35% to 100%.

See section 5 for the BITZER CS series solenoid layout and control.

3 Step Capacity Control		
RC2-100, RC2-140, RC2-180	SV 75% (NC)	SV 50% (NC)
100% Full Load	de-energized	de-energized
66% of Full Load	de-energized	energized
33% (for starting)	energized	de-energized

4 Step Continuous Stepless Capacity Control			
RC2-170, RC2-200 to RC2-1520	SV 25% (NC)	SV 75% (NC)	SV 50% (NC)
100% Full Load	de-energized	de-energized	de-energized
75% of Full Load	de-energized	energized	de-energized
50% of Full Load	de-energized	de-energized	energized
25% (for starting)	energized	de-energized	de-energized

Continuous Stepless Capacity Control			
Capacity Mode	SV1 (NC) Standard	SV2 (NC) Standard	SV2 (NO) Option
Start	energized	de-energized	energized
Loading	de-energized	energized	de-energized
Unloading	energized	de-energized	energized
Stable	de-energized	de-energized	energized

When Hanbell screw compressors operate in part or full load within limits, there will be an increase in the motor coil and discharge temperatures.

In order to enable compressor to operate in succession safely, it is important to have the various kinds of auxiliary cooling devices properly installed which would require (1) Oil cooler (2) Liquid injection for chamber (3) Liquid injection for motor cooling.

9.7 Capacity Control (Continued)

Capacity control set-ups are dependent on type of capacity control options used with the compressor.

Original Capacity Control 25-100%

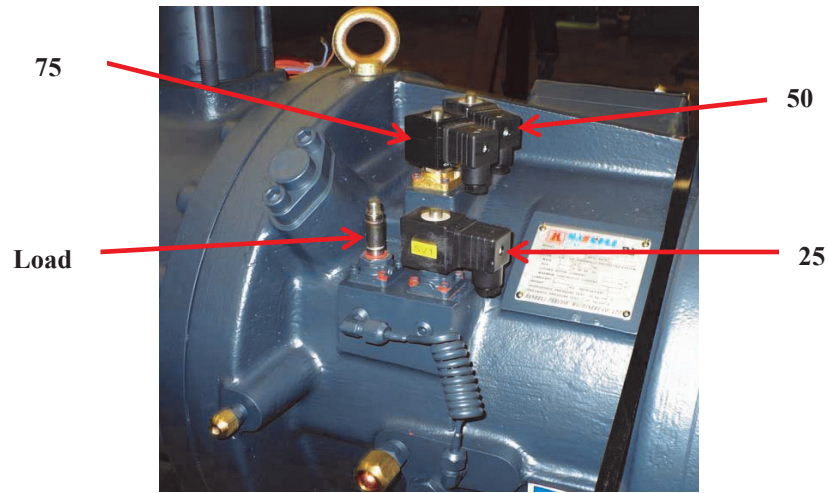
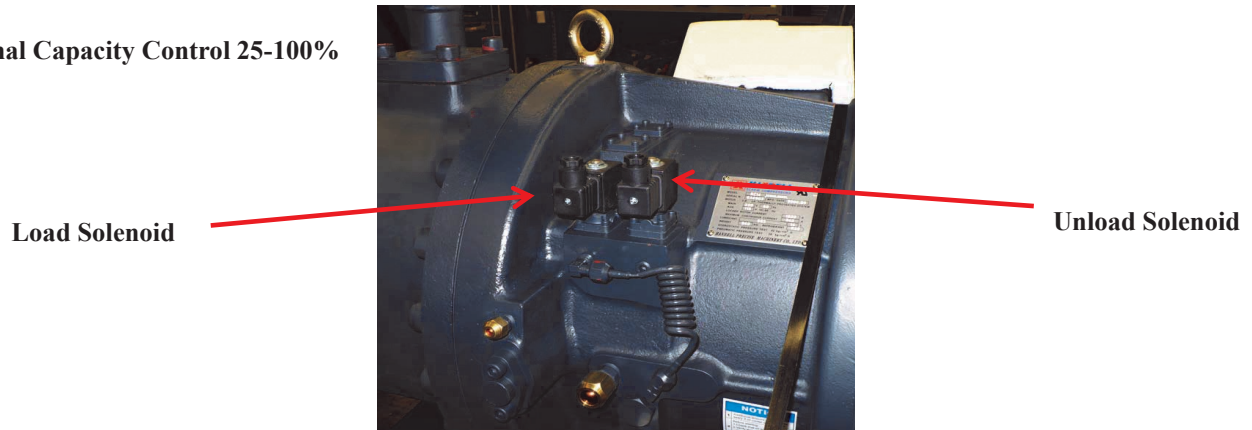

Standard Step Capacity Control (25, 50, 75, 100) (33, 66, 100)

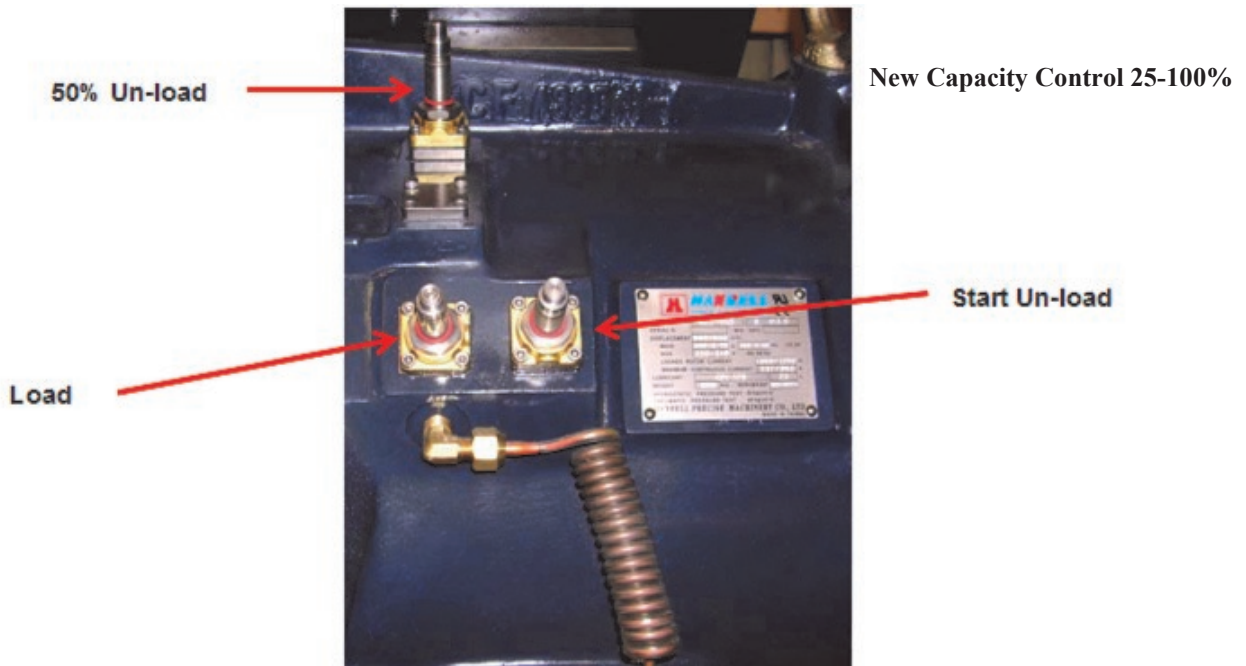

New Capacity Control 25-100%

9 Hanbell RC Series to BITZER CS Series

9.8 Oil and Refrigerant Types

Hanbell Refrigerant and Oil Types		
Refrigerant Type	Standard Factory Oil	Alternate Lubricant
R22	Sun-Sunisco-5GS	CPI CP4214-320 or Mobil EAL 100
R134A, R407C, R404A	CPI Solest 370	Mobil EAL 100 or ICI Emkarate RL421

BITZER Refrigerant and Oil Types for CSH Series		
Refrigerant Type	Standard Factory Oil	Alternate Lubricant
R22	B320SH	None
R134A, R407C, R404A, R507A, R507F	BSE 170	Solest 170, Emkarate RL170H, Reniso SE170

BITZER Refrigerant and Oil Types for CSW Series		
Refrigerant Type	Standard Factory Oil	Alternate Lubricant
R22	B320SH	None
R134A	BSE 170L	None
R407C	BSE170	Solest 170, Emkarate RL170H, Reniso SE170

9.9 Connection Sizes and Weight Comparisons

RC Model	Suction Conn.	Discharge Conn.
RC2-100B	1-5/8"	2-1/8"
RC2-140B	1-5/8"	2-1/8"
RC2-170B	1-5/8"	2-5/8"
RC2-180B	1-5/8"	2-5/8"
RC2-200B	1-5/8"	2-5/8"
RC2-230B	3-1/8"	2-1/8"
RC2-260B	3-1/8"	2-1/8"
RC2-300B	3-1/8"	2-1/8"
RC2-310B	3-1/8"	2-1/8"
RC2-320B	3-1/8"	2-1/8"
RC2-340B	4-1/8"	2-5/8"
RC2-370B	4-1/8"	2-5/8"
RC2-410B	4-1/8"	2-5/8"
RC2-470B	4-1/8"	2-5/8"
RC2-510B	4-1/8"	3-1/8"
RC2-550B	4-1/8"	3-1/8"
RC2-580B	5"	3"
RC2-610B	5"	3"
RC2-620B	5"	3"
RC2-710B	5"	4"
RC2-790B	5"	4"
RC2-830B	5"	4"
RC2-930B	5"	4"
RC2-1020B	5"	4"
RC2-1090B	6"	5"

CSH Model	Suction Valve	Discharge Valve
6553-50	2-1/8"	1-5/8"
6563-60	2-1/8"	1-5/8"
7553-70	3-1/8"	2-1/8"
7563-80	3-1/8"	2-1/8"
7573-90	3-1/8"	2-1/8"
8553-110	4-1/8"	3-1/8"
8563-125	4-1/8"	3-1/8"
8573-140	4-1/8"	3-1/8"
9553-180	4-1/8"	3-1/8"
9563-210	4-1/8"	3-1/8"
9573-240	4-1/8"	3-1/8"

CSW Model	Suction Valve	Discharge Valve
6583-50	2-5/8"	2-1/8"
6593-60	2-5/8"	2-1/8"
7573-70	3-1/8"	2-1/8"
7583-80	3-1/8"	2-1/8"
7593-90	3-1/8"	2-1/8"
8573-110	4-1/8"	3-1/8"
8583-125	4-1/8"	3-1/8"
8593-140	4-1/8"	3-1/8"

Bitzer CSH Model	Bitzer Weight
6553-50	717
6563-60	717
7553-70	1147
7563-80	1158
7573-90	1180
7583-100	1191
7593-110	1224
8553-110	1874
8563-125	1896
8573-140	1918

Bitzer CSW Model	Bitzer Weight
6583-50	805
6593-60	805
7573-70	1147
7583-80	1169
7593-90	1180
8573-110	1874
8583-125	1896

Hanbell Model Number	Weight	Hanbell Model Number	Weight	Hanbell Model Number	Weight
RC2-100B	617	RC2-310B	1279	RC2-580B	1852
RC2-140B	628	RC2-320B	1323	RC2-610B	2116
RC2-170B	828	RC2-340B	1367	RC2-620B	1940
RC2-180B	739	RC2-370B	1411	RC2-710B	2423
RC2-200B	937	RC2-410B	1631	RC2-790B	2601
RC2-230B	1224	RC2-470B	1786	RC2-830B	2679
RC2-260B	1235	RC2-510B	1720	RC2-930B	2734
RC2-300B	1323	RC2-550B	1874	RC2-1020B	3153

9 Hanbell RC Series to BITZER CS Series

9.10 Outline Drawings

RC2-100~RC2-180 Outline

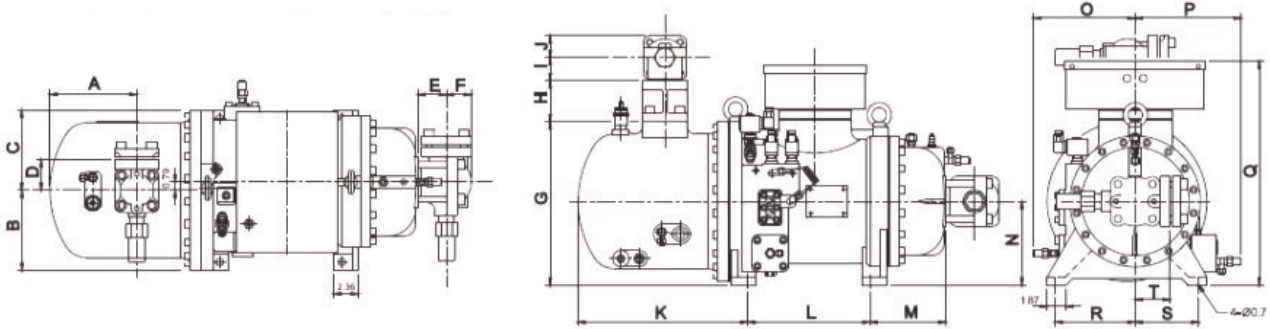

	A	B	C	D	E	F	G	H	I	J	K	L	M	N	O	P	Q	R	S	T
RC2-100	213	196	196	75	70	61	400	101	57	53	417	300	187	205	249	260	549	196	156	86
RC2-140	213	196	186	75	70	61	400	101	57	53	417	300	187	205	249	260	549	196	156	86
RC2-180	283	196	196	75	81	69	410	101	57	53	487	386	196	205	249	260	549	196	156	95

RC2-170~RC2-620 Outline

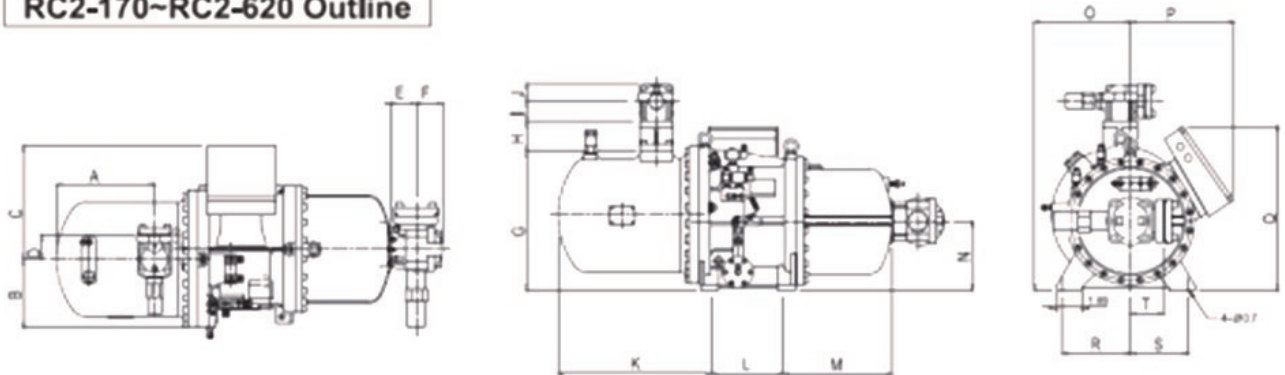

	A	B	C	D	E	F	G	H	I	J	K	L	M	N	O	P	Q	R	S	T
RC2-170	310	229	378	75	82	69	447	101	57	53	501	200	341	225	245	362	592	225	225	95
RC2-200	345	229	378	75	82	69	447	101	57	53	536	228	341	225	245	362	592	225	225	95
RC2-230	365	250	405	86	97	85	502	106	67	61	567	251	399	257	289	391	624	240	240	107
RC2-260	365	250	405	86	97	85	502	106	67	61	567	251	399	257	289	391	624	240	240	107
RC2-300	408	250	405	86	97	85	502	106	67	61	610	285	339	257	289	391	624	240	240	107
RC2-310	408	250	405	86	97	85	502	106	67	61	610	251	444	257	289	391	624	240	240	107
RC2-320	408	250	405	86	97	85	502	106	67	61	610	285	339	257	289	391	624	240	240	107
RC2-340	408	250	405	95	103	105	502	121	81	69	610	285	447	257	310	391	624	240	240	130
RC2-370	408	250	405	95	103	105	502	121	81	69	610	285	447	257	310	391	624	240	240	130
RC2-410	392	275	453	95	103	105	553	120	81	69	613	288	433	275	315	413	655	270	230	130
RC2-470	440	275	453	95	103	105	553	120	81	69	661	320	433	275	315	413	655	270	230	130
RC2-510	465	275	453	107	103	105	560	132	97	88	696	288	484	275	331	413	655	270	230	130
RC2-550	484	275	452	107	103	105	572	132	97	88	720	320	477	275	331	412	659	270	270	130
RC2-580	465	275	453	107	103	105	560	132	97	88	691	320	484	275	331	413	655	270	230	130
RC2-620	484	275	452	107	220	124	572	132	97	88	720	320	525	280	331	412	659	270	270	161

9.10 Outline Drawings (Continued)

RC2-610~RC2-930 Outline

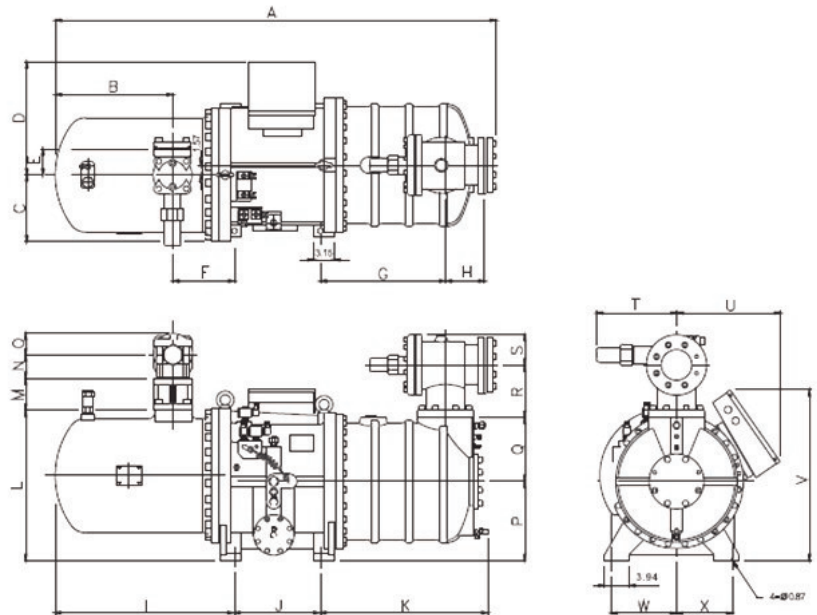

	A	B	C	D	E	F	G	H	I	J	K	L	M	N	O	P	Q	R	S	T	U	V	W	X
RC2-610	1813	484	275	466	107	253	515	161	737	353	690	617	132	97	88	325	263	216	124	331	426	701	270	230
RC2-710	1899	560	275	466	130	263	515	161	823	353	690	617	132	103	105	325	263	216	124	350	426	701	270	230
RC2-790	1964	560	275	466	130	263	515	161	823	418	690	617	132	103	105	325	263	216	124	350	426	701	270	230
RC2-830	1964	560	275	466	130	263	515	161	823	418	690	617	132	103	105	325	263	216	124	350	426	701	270	230
RC2-930	2034	560	275	466	130	263	585	161	823	418	760	617	132	103	105	325	263	216	124	350	426	701	270	230

RC2-1090~RC2-1520 Outline

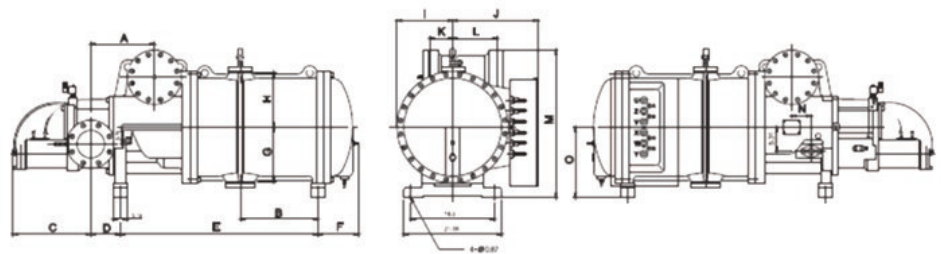

	A	B	C	D	E	F	G	H	I	J	K	L	M	N	O
RC2-1090	358	435	437	165	1110	228	309	309	313	478	130	250	830	110	398
RC2-1280	383	435	522	165	1160	228	309	309	313	478	132	265	873	133	398
RC2-1520	383	435	522	165	1160	228	309	309	313	478	132	265	873	103	398

10 Hartford Dunham Bush NHF Series

10.1 Overview

Sizing Information:

For replacement compressor selection a CFH comparison of each compressor is given in section 2 and dimensional information is given in section 4.

Mechanical Information:

The suction and discharge connections are different between the Dunham-Bush and the Bitzer compressors.

The Dunham Bush Screw has the suction valve located on the suction boss on the side of the compressor. The discharge valve is located on top of the compressor at the discharge boss for the Dunham-Bush 127mm J versions, 127mm K versions, 102mm J versions and 110mm L versions. The Dunham-Bush 110mm K version relocated the discharge port to the side of the upper enclosure making the discharge horizontal instead of vertical.

The Bitzer compressor service valves are located on the top for the CSH6553-50 through the CSH8573-140. The suction valve connection is located on the end for the CSH9553-180 through the CSH9573-240. The connection sizes are also different and the size information is supplied.

Piping and re-configuration will have to be completed when installing the BITZER CS compressor.

The weights of the compressors are similar and listed for comparison.

Wiring Information:

The control wiring for these compressors also has some differences.

The Dunham-Bush standard module included with new compressors is the Kriwan INT369R compressor protection module where the control circuit is wired through terminals M1 and M2 and module power is connected to L1 & L2. The Dunham-Bush motor protector has four motor temperature sensors (thermistors) embedded in the motor windings wired in parallel to the controller.

The Bitzer CSH series utilizes a SE-E1 electronic module.

The control circuit is wired through terminals 11 & 14 and module power is connected to L & N.

There is an additional connection on the SE-E1 electronic module at terminal 12. This can be used to indicate a general compressor fault.

The Bitzer temperature sensors (thermistors) are embedded in the motor windings and are wired in series (T1 and T2) with the discharge gas temperature sensor into the SE-E1.

Operational Information:

The loading and unloading of the compressors is slightly different. The Dunham-Bush compressor can be loaded or unloaded anywhere from 20% to 100% load. The Dunham-Bush compressor can also be held at any part load condition desired by the controller.

The Bitzer CS series of compressors can be applied in various configurations with “no” modification to the compressor required.

Depending on the number of capacity solenoids used, the compressor can be applied either 4 step capacity control (25, 50, 75 and 100% control), 25 to 100% Infinite capacity control where only 2 of the solenoids are used and even 3 Step capacity control where only 3 of the solenoids are used generally with a 50% minimum. By pulsing these solenoids back and forth, any part load condition can be achieved between 25% to 100% load.

In applications where reduced voltage starting is used the Dunham-Bush compressors can utilize Part Wind or Star Delta starting. This is different than the Bitzer compressors which use part winding starting for the CSH6553-50 through the CSH8573-140. The CSH9553-180 through CSH9573-240 utilizes Star Delta reduced voltage starting. Full voltage or direct on line starting is the same for both compressors.

The overload relay, wiring size and the contactors must be checked for proper sizing on all replacements.

10.2 Scope of Standard Delivery

Scope of Standard Delivery (as supplied by Manufacturer)	Bitzer CSH	Hartford NHF (MSC)
Capacity control system : 4-Steps or Infinite Continuous (See Below)	No Modification Req	2 Step
25% to 100% Capacity Control	●	●
Conversion Kit Stepped to Stepless Control	Not Required	No
4 Step Capacity Control	●	No
Infinite Capacity Control	●	●
Solenoid coils for capacity control	●	Δ
Volume ratio Vi, Option Vi=2.2, 2.6, 3.0, 3.5	Built In	Δ
Discharge Check Valve	● Internal	Suction
Suction Coupling tube and/or Flange	N/A	Δ
Discharge Coupling tube and/or Flange	N/A	Δ
Suction Service Valve	●	Δ
Discharge Service Valve	●	Δ
Suction service valve location	Top	Side
Discharge service valve location	Top	Top or Side
Oil Charge	●	●
Electronic Module (Rotation)	●	Δ
Electronic Module (Temperature)	●	Δ
PTC100 type temperature sensor	N/A	N/A
PTC120 type temperature sensor	●	N/A
PT100 type motor temperature sensor	PTC Sensors	N/A
PTC110 type temperature sensor	N/A	N/A
Screw in Discharge temperature sensor	● (251F)	● (240F)
IP-54 Terminal box	●	
Crankcase oil heater	●	●
Compress chamber (Middle side) liquid inject port	●	
Motor side (Low side) liquid inject port	Not Required	
Economizer port	●	●
Oil cooling connection	●	●
Liquid injection oil cooling port	●	●
Oil drain valve	●	●
Oil level switch	Δ	●
Oil filter different pressure (ΔP) protector switch	Not Required	Not Required
Liquid injection expansion valve	N/A	Δ
Liquid injection solenoid valve	N/A	Δ
Safety Valve	● Internal	Δ
Position sensor (Capacity control)	N/A	N/A
Slide fit motor	●	No
Starting type PWS	●	●
Starting type Start Delta	Δ	Δ
Jumper bars for DOL starting	●	Δ
Rubber mounting pads	●	Δ
Oil Separator	Intregal	Intregal

● (Standard) Δ (Option) N/A Not Applicable

10 Hartford Dunham Bush NHF Series

10.3 Model Number Nomenclature and Oil Type

See section 1 for the BITZER CS series model number nomenclature.

MSC127 Series

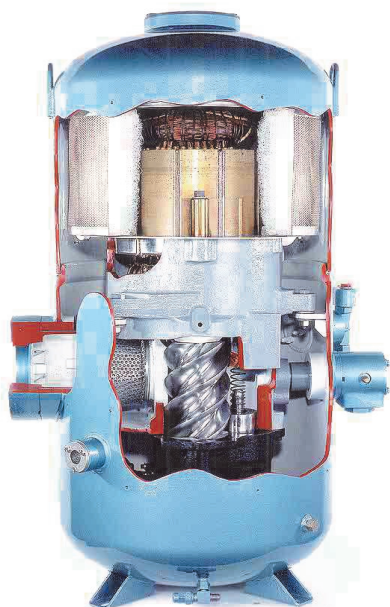

MSC110 Series

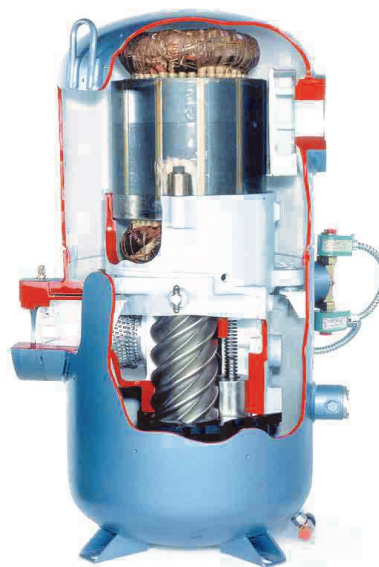

DB Model Number Nomenclature

MODEL (Example): 1215NHF6W4K0EMBJOC

12	15	N	H	F
Rotor Diameter	Rotor L/D Ratio	Compressor Type	Temp App	Refrigerant
12 = 127mm 11 = 110mm	10 = 1.00 12 = 1.25 15 = 1.50 18 = 1.80	B = Flanged Semi N = Fully Hermetic	H = High L = Commercial U = Low	F = R22,404A,407C,507 L = R134A
6	W	4	K	OEM
Unloading	Injection Type	Motor Sizing	Version	Assembly Level
6 = Auto Start	V = Vapor & Liquid W = Vapor Only X = Vapor & Liquid	3=Undersized by 2 4=Undersized by 1 5=Nominal 6=Oversized by 1	K=w/cast iron J=1215/1216 RMF	OEM = OEM RMF= Remanufactured
BJ	O	C		
Motor Voltage	Start Method	Control Voltage		
AK=200/3/60 AM=220/3/50 BJ=400-460/3/50-60 BK=200-230/3/50-60 CA=500-575/3/50-60 CS=346-400/3/50-60 CU=415-480/3/50-60	O=2 Step Double Delta	C=115/1/50-60 J=230/1/50-60		

Hartford Dunham Bush uses 4GS Mineral Oil on all R22 Applications

10.4 Capacity Control

Please see section 5 for more BITZER solenoid valve information

For the Dunham Bush Compressor		
Operation	Solenoid A	Solenoid B
Loading	On	On
Unloading	Off	Off
Hold	Off	On

For the Bitzer Screw Compressor-Infinite Capacity Control 25-100%		
Operation	Solenoid 3	Solenoid 4
Start/stop	Energized	De-energized
Loading	De-energized	Pulsing
Unloading	Pulsing	De-energized

Dunham Bush MSC Series 1210, 1212, 1215, 1218 Capacity Control

Top
Solenoid Valve "B"
Unload
Normally Open

Bottom
Solenoid Valve "A"
Load
Normally Closed



For the Bitzer Screw Compressor-4-Step Capacity Control				
Operation	Solenoid 1	Solenoid 2	Solenoid 3	Solenoid 4
Start/stop	De-energized	De-energized	Energized	Pulsing
Capacity 25%	De-energized	De-energized	Energized	Pulsing
Capacity 50%	De-energized	Energized	De-energized	Pulsing
Capacity 75%	Energized	De-energized	De-energized	Pulsing
Capacity 100%	De-energized	De-energized	De-energized	Energized

10 Hartford Dunham Bush NHF Series

10.5 Modules and Wiring

The Bitzer CSH and CSW series utilizes a SE-E1 electronic module as standard. The SE-E1 is a dual voltage 110/220 volt with other voltages available. The control circuit is wired through terminals 11 & 14 and module power is connected to L & N. The oil temperature sensor and motor winding sensors (T-1 and T-2) are pre-wired to the module. The SE-E1 provides phase protection and is connected to L1, 2 and 3. There is an additional connection on the SE-E1 electronic module at terminal 12. This can be used to indicate a general compressor fault. See section 6 for an overview of the SE-E1 module.

Below are various examples and schematics of modules used on D/B compressors:

TI 41AA1500E (replaced by Kriwan INT369R)

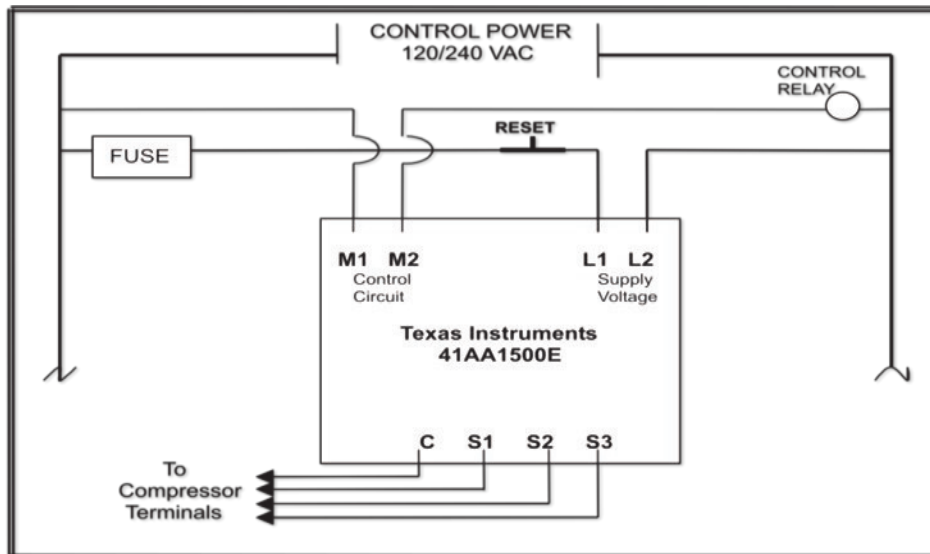

TI 2ACE (replaced by Kriwan INT369R)

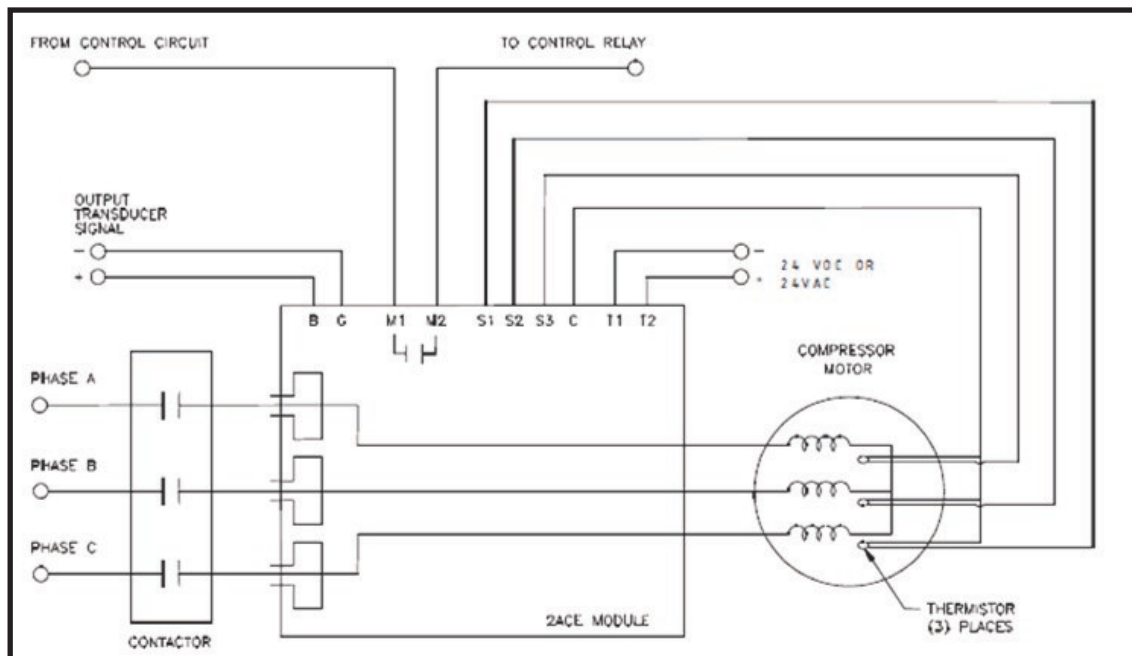

10.5 Modules and Wiring (Continued)

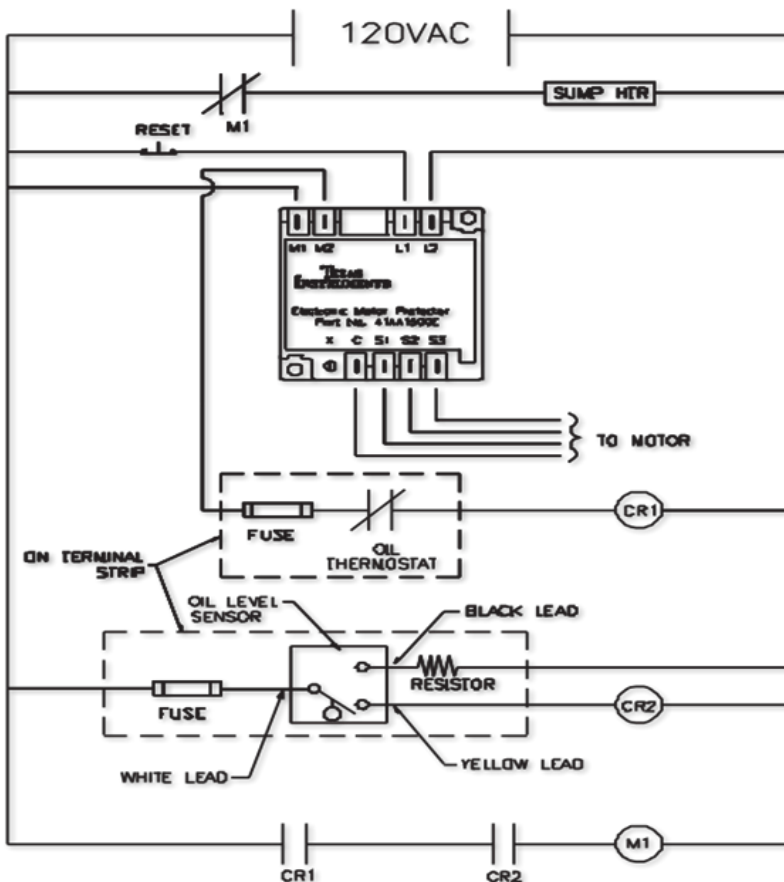

MEDIUM SCREW TERMINAL CONNECTIONS

ACROSS THE LINE START
ONE CONTACTOR

INCREMENT START
TWO CONTACTORS

FOUR POST TERMINAL WIRING

S1, S2, S3 MOTOR
SENSOR TERMINALS

MOTOR PROTECTION
COMMON (C)

NOT USED

OIL TEMP
THERMOSTAT 18, 19
(127mm ONLY)

POWER LEAD TERMINAL TIGHTENING PROCEDURE

- INSTALL POWER LEAD TERMINAL ON STUD AND TORQUE TERMINAL LUG NUT TO VALUE IN TABLE WHILE HOLDING NUT A
- MAKE SURE THAT TERMINAL STUD DOES NOT TURN WHILE TORQUING TERMINAL LUG NUT

COMP. MODEL	TORQUE	
	LB-FT	Nm
110K	8	11
127J	8	11
1210K 1212K	8	11
1215K 1218K	20	27

THERMALLY PROTECTED SYSTEM

DCM 71

Typical Terminal Box Label

10 Hartford Dunham Bush NHF Series

10.6 Starting Types and Terminal Box Wiring

MSC-127 Series

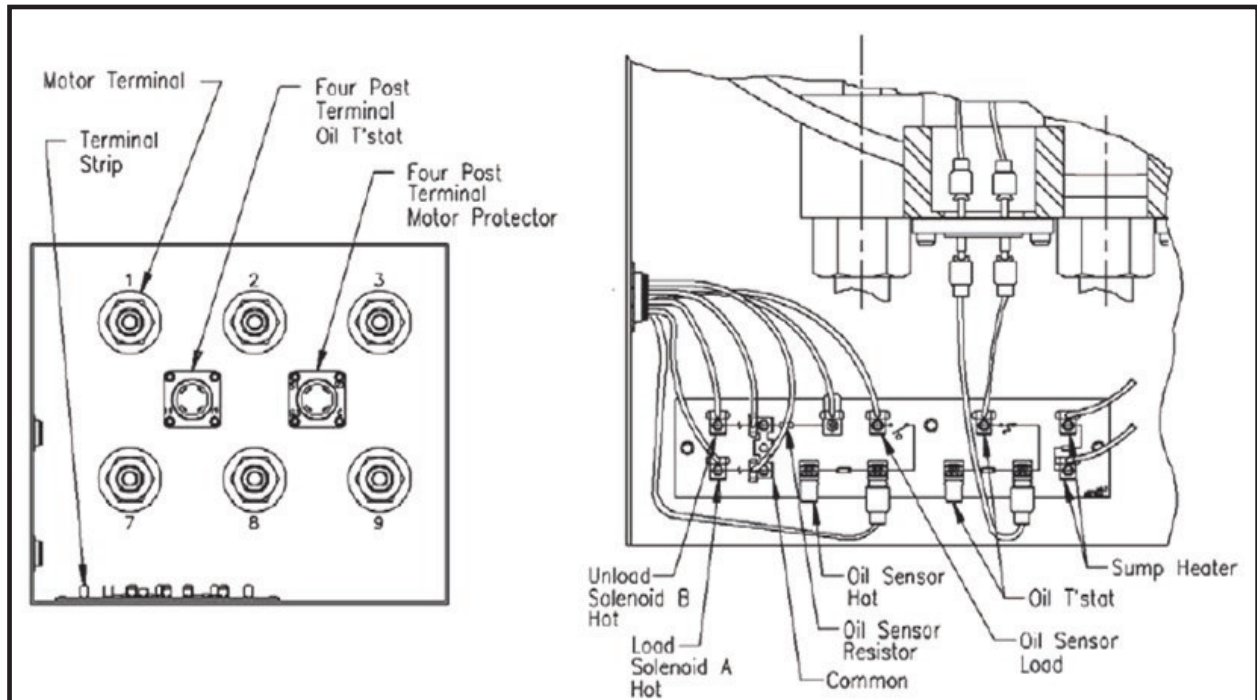

MSC-110 Series

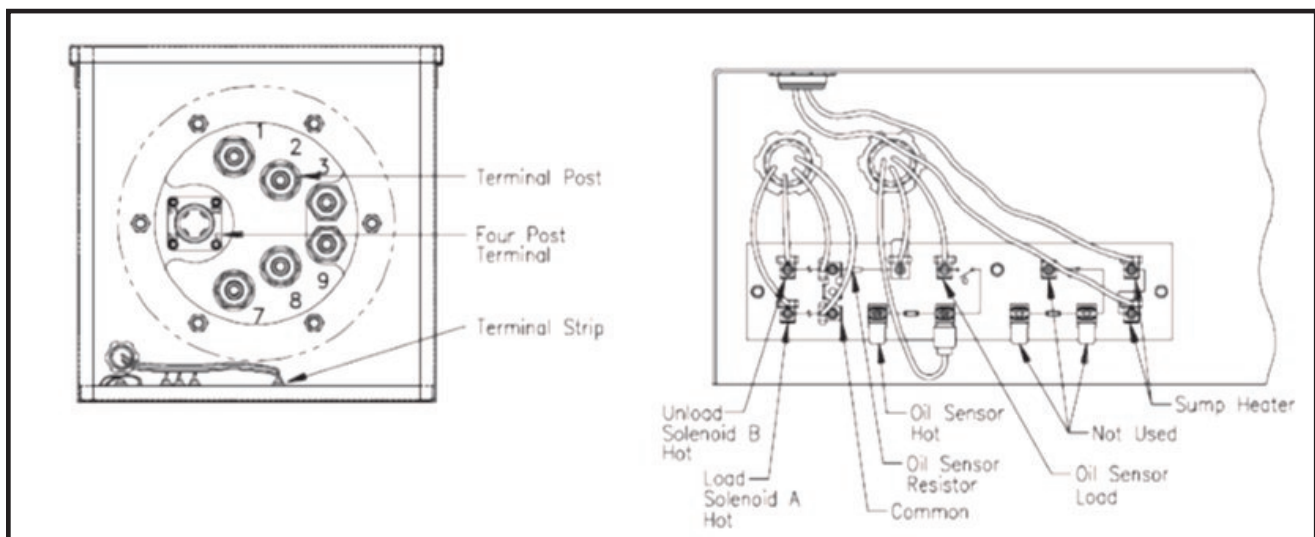

In applications where reduced voltage starting is used the Hartford D/B use Part Winding Start or have a Star - Delta starter which is different than the BITZER CS compressor. BITZER CS compressors utilize Part Winding Start or Direct on Line on all CS65, 75 and 85 compressors and Star Delta reduced voltage starting on the CS95 series. Full voltage or direct on line starting is the same for both compressors.

The overload relay and the contactors must be checked for proper sizing.

10.7 Outline Drawings

MSC 127mm Compressor Outline Drawing

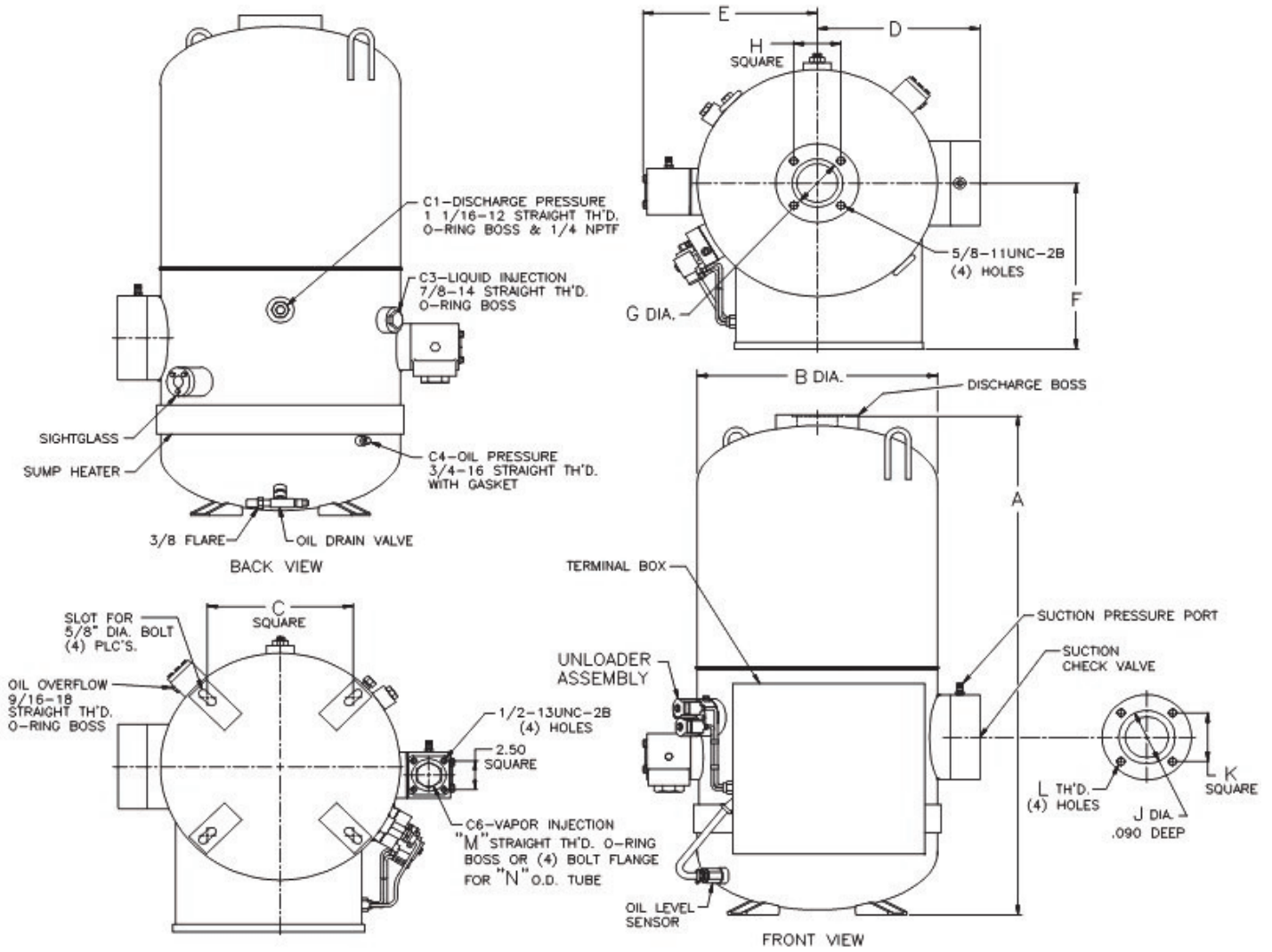

10 Hartford Dunham Bush NHF Series

10.7 Outline Drawings (Continued)

MSC 110mm Compressor Outline Drawing

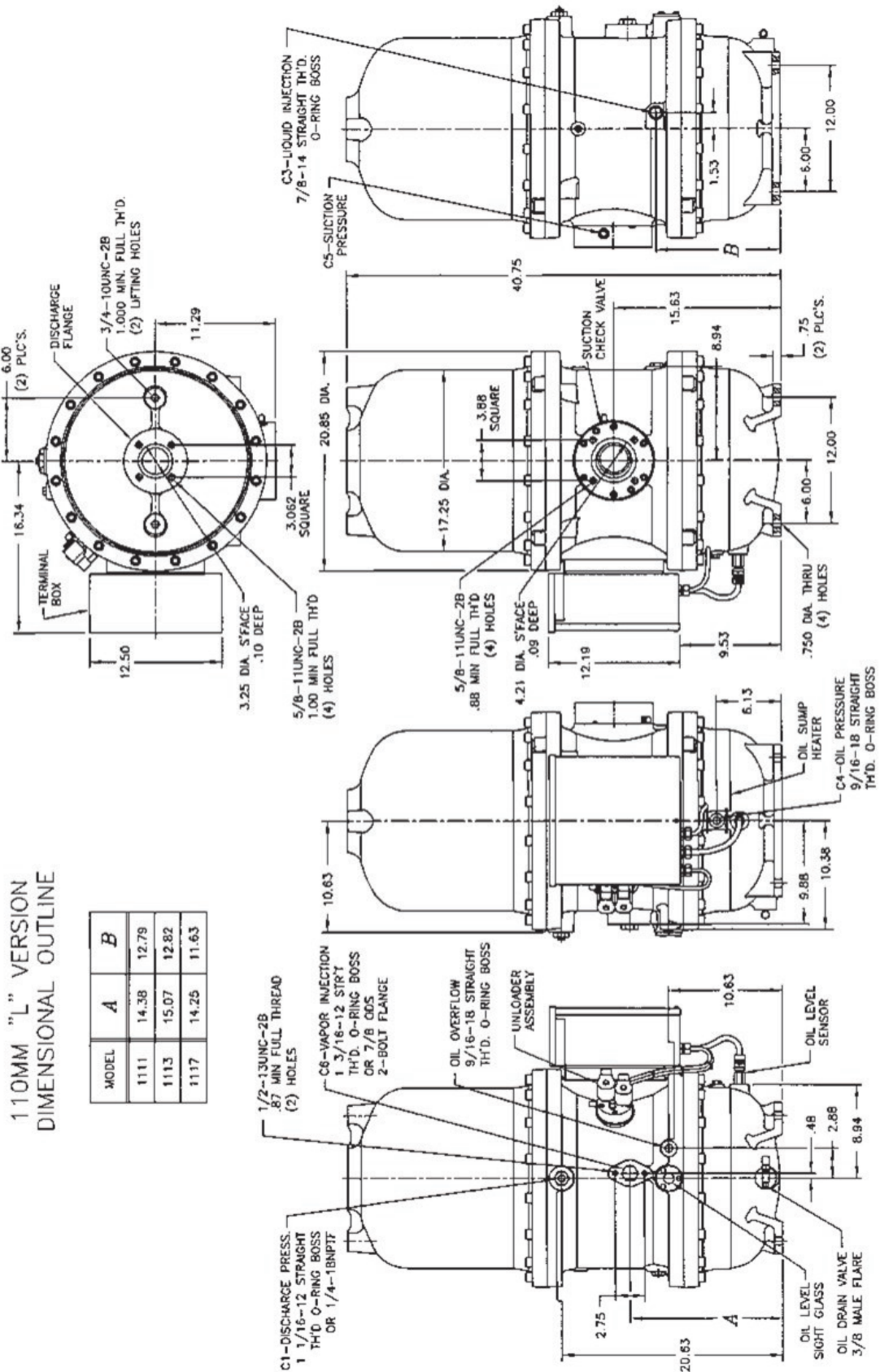

10.8 Compressor Conversion Examples

Pre and Post Pictures of Bitzer CSH7573-90-4PU
Replaced Hartford Dunham Bush
Vertical Screw Compressor 1117NHF6X6K



Pre and Post Pictures of Bitzer CSH8563-125-4PU
Replaced Hartford Dunham Bush
Vertical Screw Compressor 1215NHF6W4KBJ



Pre and Post Pictures of Bitzer CSH8573-140-4PU
Replaced Hartford Dunham Bush
Vertical Screw Compressor 1215NHF6W4JBJOC



10 Hartford Dunham Bush NHF Series

10.9 Connection Sizes and Weights

Bitzer CSH						
Model Number	Dimensions L x W x H (in)			Discharge Valve	Suction Valve	Weight (lb)
CSH6553-50	43	22	23	1 5/8	2 1/8	671
CSH6563-60	43	22	23	1 5/8	2 1/8	693
CSH7553-70	53	22	24	2 1/8	3 1/8	1058
CSH7563-80	53	22	24	2 1/8	3 1/8	1076
CSH7573-90	53	22	24	2 1/8	3 1/8	1091
CSH8553-110	60	23	29	3 1/8	4 1/8	1749
CSH8563-125	60	28	29	3 1/8	4 1/8	1762
CSH8573-140	60	28	29	3 1/8	4 1/8	1784
CSH9553-180	72	23	33	3 1/8	4 1/8	2734
CSH9561-210	72	28	33	3 1/8	4 1/8	2778
CSH9573-240	72	28	33	3 1/8	4 1/8	2800
CSH9583-280	72	28	34	4 1/8	5.00	3043
CSH9593-300	72	28	34	4 1/8	5.00	3087

Compressor is with the Suction and Discharge Service Valves

Hartford MSC Dimensions			
Model Number	Width	Height	Length
1111	25	38	28
1113	25	38	28
1117	25	38	28
1210	27	43	34
1212	27	43	34
1215	30	47	37
1218	30	47	37

MSC Model	Weight
1111	695
1113	735
1117	765
1210	1010
1212	1020
1215	1265
1218	1270

11.1 Overview

Sizing Information:

For replacement compressor selection a CFH comparison of each compressor is given in section 2 and dimensional information is given in section 4.

Mechanical Information.

The suction and discharge connections are different between the Hitachi and the BITZER compressors. The Hitachi screw has the valves located on the ends of the compressor.

The BITZER screw compressor has the valves located on the top for the CS65 thru CS85.

The suction valve connection is located on the end for the CS95.

The connection sizes are also different and the size information is provided.

The suction and discharge isolation valves as well as the discharge check valve can be removed from the existing piping, BITZER compressors are supplied with suction and discharge service valves and an internal check valve.

The weights of the compressors are similar and shown in the following pages.

Wiring Information:

The control wiring for these compressors also has some differences.

The Hitachi has a motor protection module where the control circuit is wired through terminals M1 & M2 and module power is connected to L1 & L2.

On the BITZER screw compressor the control circuit is wired through terminals 11 & 14 and module power is connected to L & N.

There is an additional connection on the protection module at terminal 12. This can be used to indicate a general compressor failure.

The external reverse phase protection that was used for the Hitachi must be removed as this function is incorporated into the BITZER screw protection module.

Operational Information:

The loading and unloading for capacity control of the compressors is also very similar and will be described in the following pages.

The last thing that needs to be checked is starting.

In applications where reduced voltage starting is used the Hitachi will have a Star Delta starter. This is different than the BITZER screw compressor, which uses part winding starting for the CS65, 75 and 85 series. The CS95 series utilize Star Delta reduced voltage starting.

Full voltage or direct on line starting is the same for both compressors.

The overload relay and the contactors must be checked for proper sizing.

11 Hitachi SC Series

11.2 Scope of Standard Delivery

Scope of Standard Delivery (as supplied by Manufacturer)	Bitzer CSH	Hitachi SC
Capacity control system : 4-Steps or Infinite Continuous	No Modification Req	No
25% to 100% Capacity Control	●	No
Conversion Kit Stepped to Stepless Control	Not Required	No
4 Step Capacity Control	●	No
Infinite Capacity Control	●	Δ
Solenoid coils for capacity control	●	Δ
Volume ratio Vi, Option Vi=2.2, 2.6, 3.0, 3.5	Built In	Built In
Discharge Check Valve	● Internal	Δ External
Suction Coupling tube and/or Flange	N/A	●
Discharge Coupling tube and/or Flange	N/A	●
Suction Service Valve	●	Δ
Discharge Service Valve	●	Δ
Suction service valve location	Top	End
Discharge service valve location	Top	End
Oil Charge	●	●
Electronic Module (Rotation)	●	Δ
Electronic Module (Temperature)	●	Δ
PTC100 type temperature sensor	N/A	
PTC120 type temperature sensor	●	
PT100 type motor temperature sensor	PTC Sensors	
PTC110 type temperature sensor	N/A	
Screw in Discharge temperature sensor	● (251F)	● (248F)
IP-54 Terminal box	●	
Crankcase oil heater	●	Δ
Compress chamber (Middle side) liquid inject port	●	
Motor side (Low side) liquid inject port	Not Required	
Economizer port	●	
Oil cooling connection	●	
Liquid injection oil cooling port	●	●
Oil drain valve	●	
Oil level switch	Δ	
Oil filter different pressure (ΔP) protector switch	Not Req	Not Req
Liquid injection expansion valve	N/A	Δ
Liquid injection solenoid valve	N/A	Δ
Safety Valve	● Internal	Δ
Position sensor (Capacity control)	N/A	N/A
Slide fit motor	●	No
Starting type PWS	●	No
Starting type Start Delta	Δ	●
Jumper bars for DOL starting	●	Δ
Rubber mounting pads	●	Δ
Oil Separator	Integral	Integral

11.3 Motor Horsepower and CFH Comparison

Compressor Horsepower Rating			
Hitachi Model	Hitachi SC-Z or H (converted from kW)	BITZER Model	Bitzer CSH
4005 SC	54	6553-50	50
5005 SC	67	6563-60	60
6005 SC	80.5	7553-70	70
10001 SC	134	8553-110	110

CFH Ratings			
Hitachi Model	Hitachi SC-Z or H	BITZER Model	Bitzer CSH
4005 SC	5850	6553-50	5830
5005 SC	7212	6563-60	7244
6005 SC	8880	7553-70	8410
10001 SC	13950	8553-110	13428

11 Hitachi SC Series

11.4 Dimension, Weight, Connection and Oil Comparison

Hitachi Dimensions			
Model	Length	Height	Width
4005 SC	52"	22"	16"
5005 SC	56"	23"	18"
6005 SC	57"	23"	18"
10001 SC	59"	23"	25"
Without Service Valves			

Bitzer CSH Dimensions			
Model	Length	Height	Width
6553-50	44"	22"	19"
6563-60	44"	22"	19"
7553-70	53"	23"	22"
8553-110	60"	28"	27"
With Service Valves			

Hitachi Model	Hitachi Weight	Bitzer Model	Bitzer Weight
4005 SC	795	6553-50	710
5005 SC	925	6563-60	710
6005 SC	970	7553-70	1136
10001 SC	1820	8553-110	1852

Mounting Feet Dimensions				
mm C/L	4005SC	5005SC	6005SC	10001SC
Length	335	445	445	662
Width	300	360	360	445

Mounting Feet Centerline			
(mm)	CS65	CS75	CS85
Length	457	457	695
Width	305	305	400

Hitachi Model	Suction Connection	Discharge Connection
4005 SC	2-1/8"	1-5/8"
5005 SC	2-1/8"	1-5/8"
6005 SC	2-1/8"	1-5/8"
10001 SC	3-5/8"	2-5/8"

CSH Model	Suction Valve	Discharge Valve
6553-50	2-1/8"	1-5/8"
6563-60	2-1/8"	1-5/8"
7553-70	3-1/8"	2-1/8"
8553-110	4-1/8"	3-1/8"

Hitachi Model	Oil Charge (Liters)	R22 Oil Type
4005 SC	6	Hitachi SR30 / Suniso 4GS / SW220HT
5005 SC	7	
6005 SC	7	
10001 SC	10	

CSH Model	Oil Charge (Gallons)	R22 Oil Type
6553-50	2.6	CPI4214-320
6563-60	2.6	
7553-70	4.1	
8553-110	6	

11.5 Capacity Control

See section 5 for additional information for the BITZER CS Capacity Control.

Bitzer Infinite Control

- #3 Unload or Minimum Capacity
- #4 Load or Maximum Capacity Control

Minimum Capacity = 25%

Operation of Solenoids

- #3 coil is "pulsed" to the desired capacity required
- #4 coil is "pulsed" to the desired capacity required

Starting:

- Automatic Start Unloading
- No solenoids are energized

Hitachi Infinite Control

- Solenoid A Unload or Minimum Capacity
- Solenoid B Start-Stop
- Solenoid C Load or Maximum Capacity

Minimum Capacity = 33% (4002) / 25% (5002/6002)

Operation of Solenoids

- "B" is energized to start or stop the compressor
- "C" is energized to Load the compressor
- "A" is energized to Unload the compressor

Starting:

- "B" solenoid is energized
- "B" solenoid is to maintain on for 30 seconds after starting prior to loading compressor

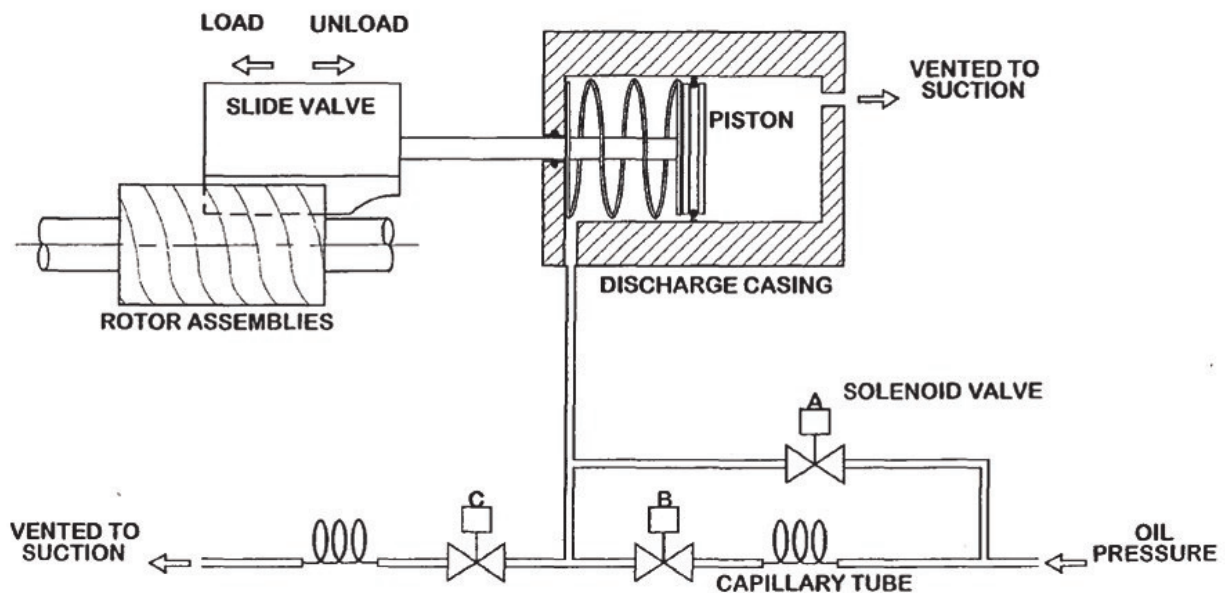

11 Hitachi SC Series

11.5 Capacity Control (Continued)

Hitachi 4002/5, 5002/5, 6002/5 Screw Compressors

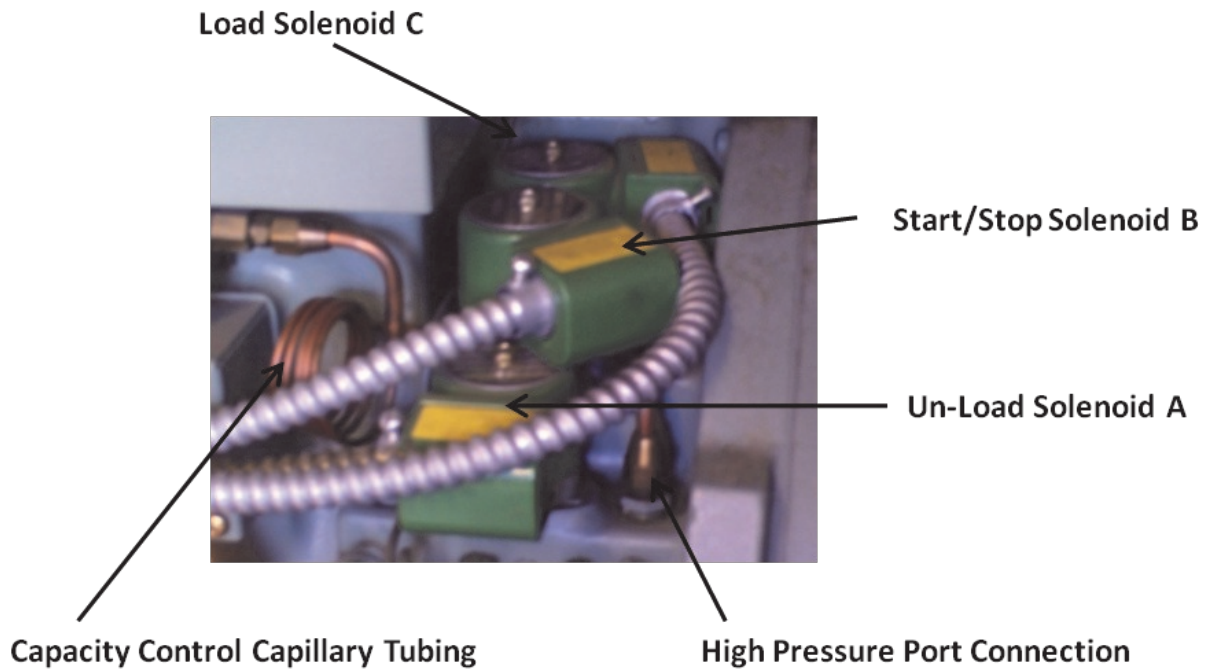

Condition	Solenoid A	Solenoid B	Solenoid C
Start/Stop	ON	OFF	OFF
Load Up	OFF	ON	OFF
Unloading	OFF	OFF	ON
Load Constant	OFF	OFF	OFF

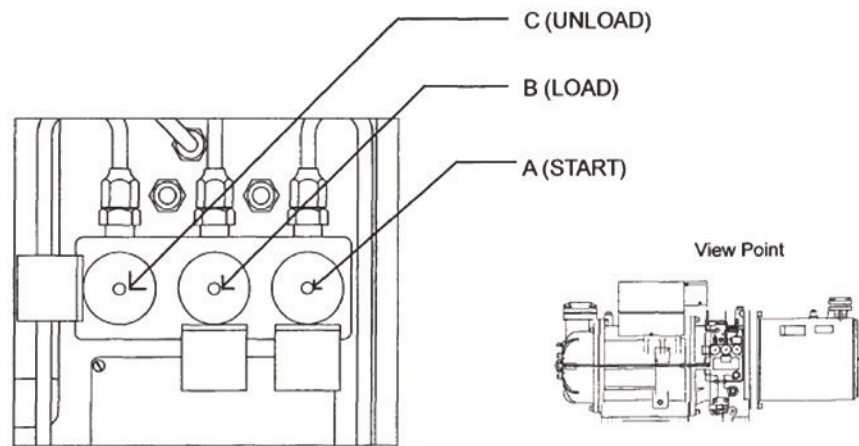

Compressor casing view from the side.

11.6 Module and Terminal Wiring

The control wiring for these compressors also has some differences.

The Bitzer CSH and CSW series utilizes a SE-E1 electronic module as standard.

The Hitachi motor protection module has the control circuit wired through terminals M1 & M2 and the module power is connected to L1 & L2.

The SE-E1 is a dual voltage 110/220 volt with other voltages available.

The control circuit is wired through terminals 11 & 14 and module power is connected to L & N.

The Hitachi standard module provides motor temperature protection (trips 194°F) and discharge gas temperature protection (trips 248°F). There is also an optional accessory for phase protection.

The oil temperature sensor and motor winding sensors (T-1 and T-2) are pre-wired to the module.

The SE-E1 provides phase protection and is connected to L1, 2 and 3.

There is an additional connection on the SE-E1 electronic module at terminal 12.

This can be used to indicate a general compressor fault.

See section 6 for an overview of the SE-E1 module.

Shown below are examples of the typical Hitachi wiring:

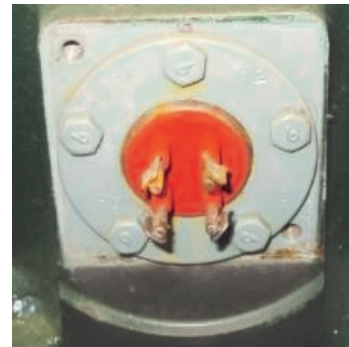
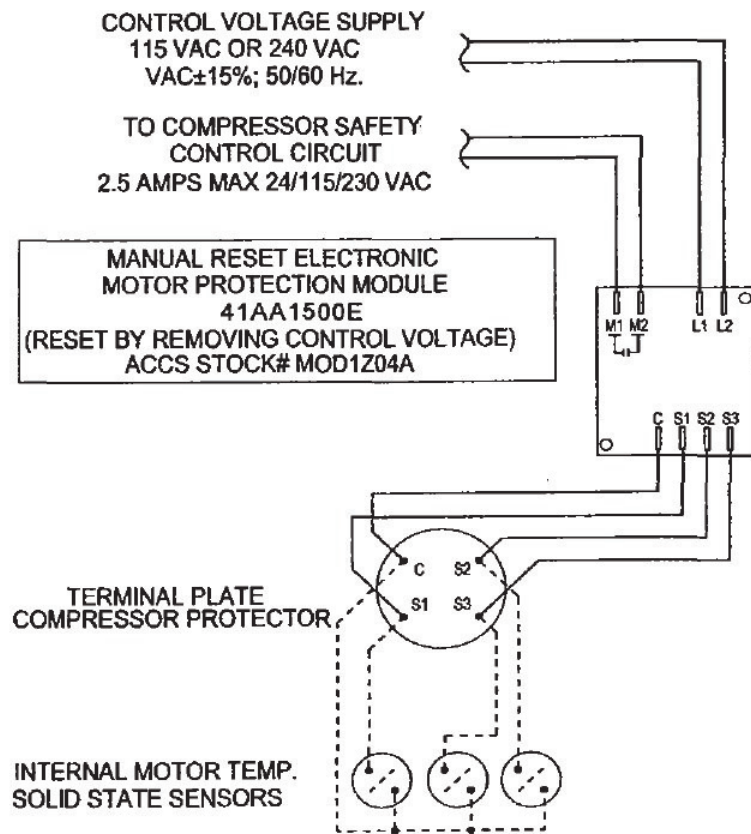

11 Hitachi SC Series

11.6 Module and Terminal Wiring (Continued)

HITACHI SRM SEMI-HERMETIC SCREW COMPRESSOR - SERIES 4002SC-H, 5002SC-H & 6002SC-H WIRING DIAGRAM FOR ACROSS-THE-LINE STARTING

MAIN SUPPLY VOLTAGE
(SPECIFY WHEN ORDERING THE COMPRESSOR)
230 VOLTS, 60 HZ, 3 PH
480 VOLTS, 60 HZ, 3 PH

NOTE:
1) TORQUE TERMINAL PLATE CONNECTIONS TO 21.7 FT.-LBS.

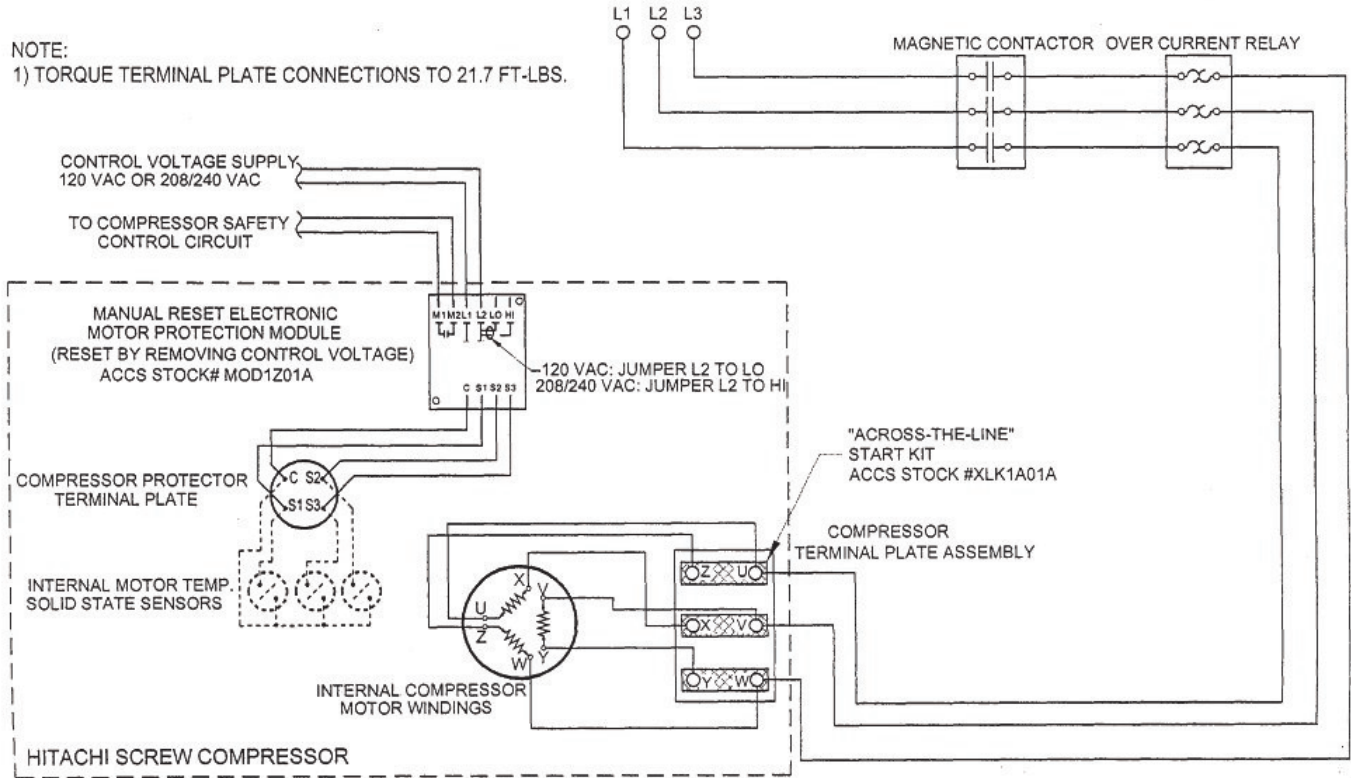

Hitachi 10001SC Series

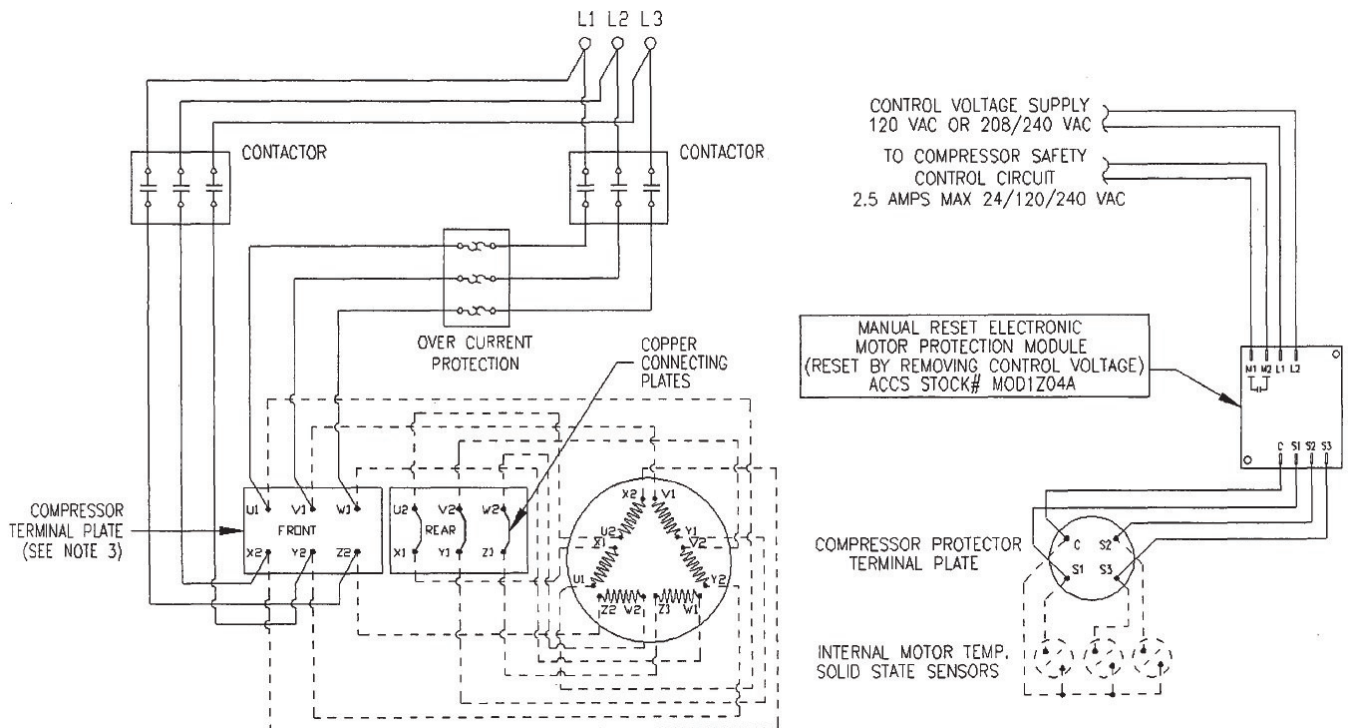

11.7 Outline Drawings

4005SC-H / 5005SC-H / 6005SC-H / 4005SC-Z / 5005SC-Z / 6005SC-Z

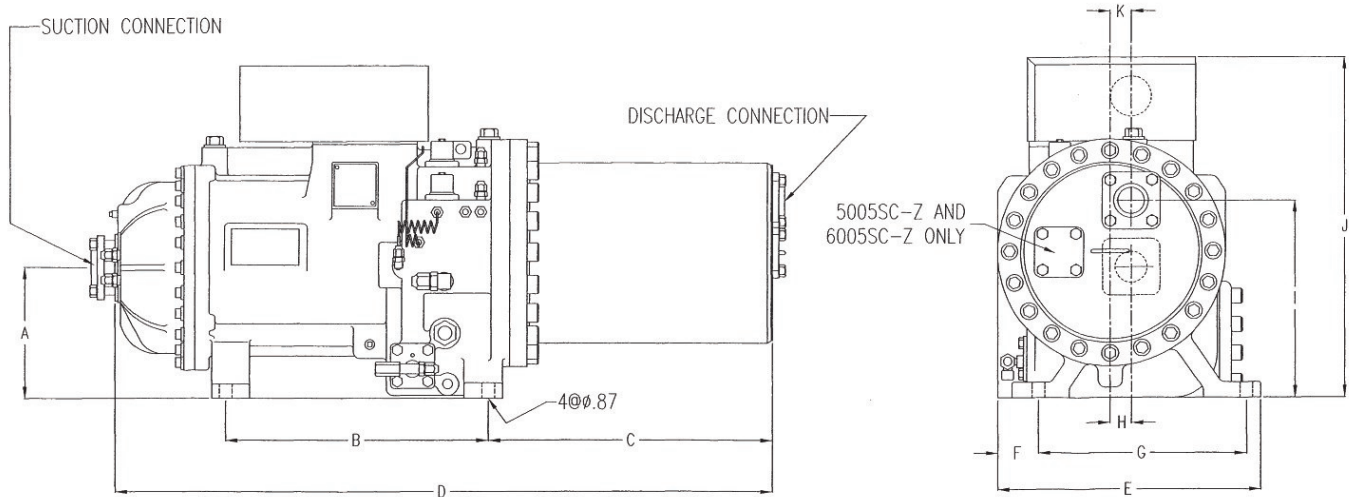

Model	A	B	C	D	E	G	J
4005SC-H/Z	7.9	13.2	19.7	41.4	16.3	11.8	22.3
5005SC-H/Z	8.9	15.5	20.6	44.8	17.9	14.2	23.3
6005SC-H/Z	8.9	15.5	20.6	46.0	17.9	14.2	23.3

10001SC-H / 10001SC-Z

(mm)

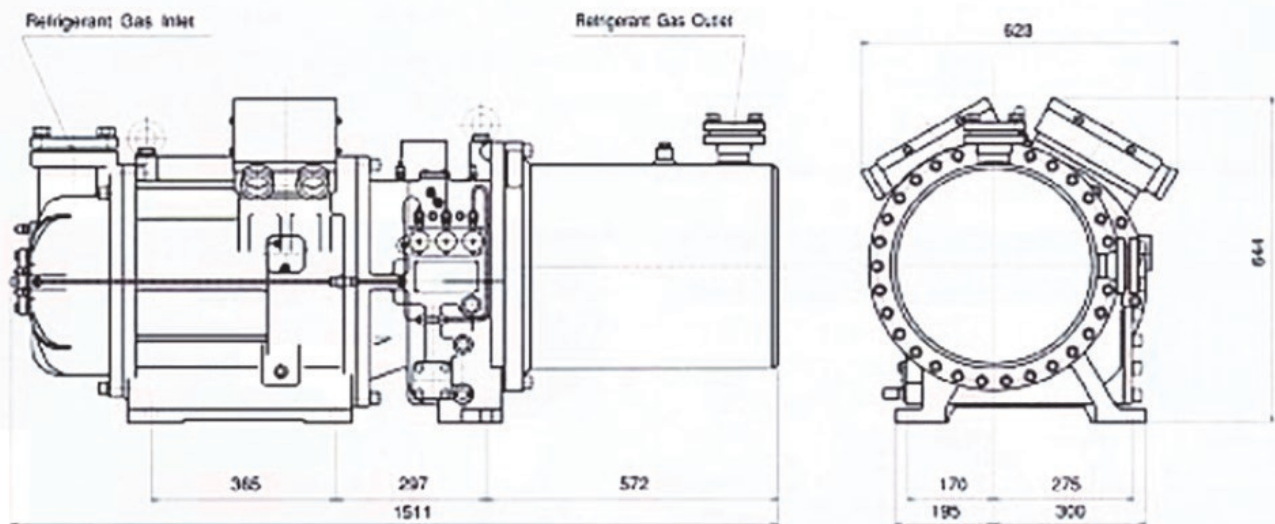

11 Hitachi SC Series

11.8 Compressor Conversion Examples

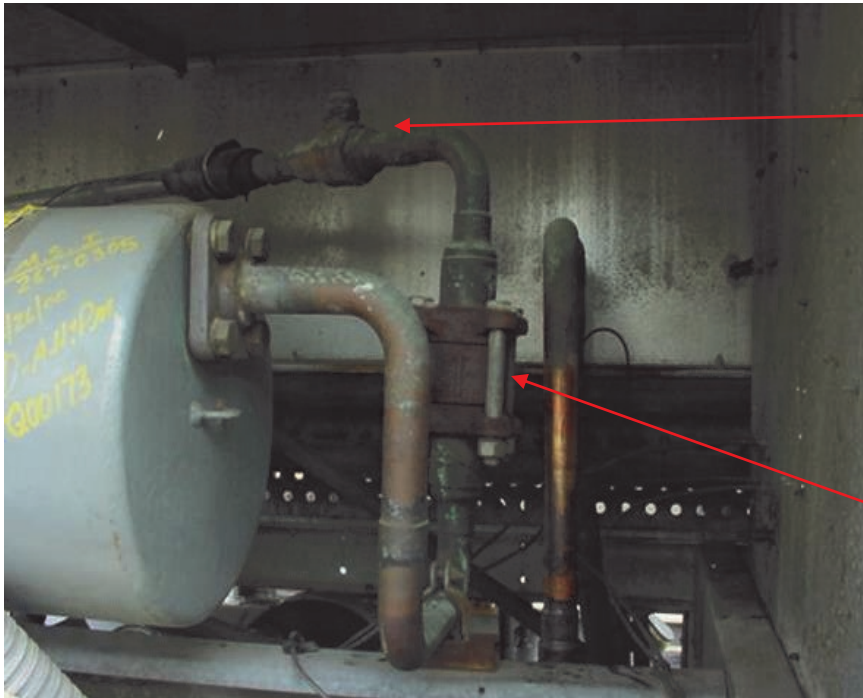

Remove Hitachi External Discharge Valve

Remove Hitachi External Discharge Check Valve



(4) 6002SC-H Screw Compressors (80 Horsepower)



(4) CSH6563-60-4PU Screw Compressors (60 Horsepower)



11.8 Compressor Conversion Examples (Continued)

CSH6553-50-4PU CS Compressors
(50 horsepower)
CSH6563-60-4PU CS Compressors
(60 horsepower)



4002SC-H Screw Compressors
(54 horsepower)
5002SC-H Screw Compressors
(67 Horsepower)

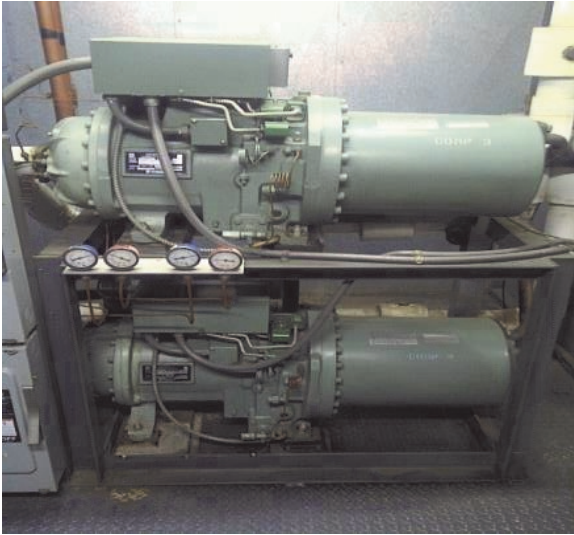

12 RefComp SRC Series

12.1 Overview

Sizing Information:

For replacement compressor selection a CFH comparison of each compressor is given in section 2 and dimensional information is given in section 4.

Mechanical Information:

The suction and discharge connection sizes are different between the RefComp and the BITZER CS compressors.

The RefComp Screw has the suction valve located on the end and the discharge valve located on top. The BITZER CS compressors have the service valves located on the top of the compressor for the CS65, 75 and 85 series.

The suction valve connection is located on the end for the CSH9553-180 through the CSH9573-240.

The suction and discharge isolation valves as well as the discharge check valve can be removed from the existing piping on the RefComp.

The BITZER CS compressors are supplied with suction and discharge service valves and an internal check valve.

The weights of the compressors are similar and listed for comparison.

Wiring Information:

The control wiring for these compressors also has some differences.

The RefComp utilizes an INT69 RCY compressor protection module.

The control circuit is wired through terminals 11 & 14 and module power is connected to L & N.

The BITZER CS utilizes a SE-E1 compressor electronic module.

The control circuit is wired through terminals 11 & 14 and module power is connected to L & N.

There is an additional connection on the BITZER CS protection module at terminal 12.

This can be used to indicate a general compressor failure.

The reverse phase and high discharge temperature protection that was used for the RefComp must be removed as this function is incorporated into the BITZER CS protection module.

The last thing that needs to be checked is starting.

In applications where reduced voltage starting is used, the RefComp will have a Star Delta starter. This is different than the BITZER screw compressor, which uses part winding starting for the CS65, 75 and 85 series. The CS95 series utilize Star Delta reduced voltage starting.

Full voltage or direct on line starting is the same for both compressors.

Operational Information:

The loading and unloading between the compressors is very similar and will be shown in the following pages.

12.2 Scope of Standard Delivery

Scope of Standard Delivery (as supplied by Manufacturer)	Bitzer CSH	RefComp SRC
Capacity control system : 4-Steps or Infinite Continuous (See Below)	No Modification Req	Δ 3 Step
25% to 100% Capacity Control	●	●
Conversion Kit Stepped to Stepless Control	Not Required	Δ
4 Step Capacity Control	●	Δ
Infinite Capacity Control	●	Δ
Solenoid coils for capacity control	●	Δ
Volume ratio Vi, Option Vi=2.2, 2.6, 3.0, 3.5	Built In	Δ
Discharge Check Valve	● Internal	● Internal
Suction Coupling tube and/or Flange	N/A	●
Discharge Coupling tube and/or Flange	N/A	N/A
Suction Service Valve	●	Δ
Discharge Service Valve	●	●
Suction service valve location	Top	End
Discharge service valve location	Top	Top
Oil Charge	●	●
Electronic Module (Rotation)	●	Δ
Electronic Module (Temperature)	●	●
PTC100 type temperature sensor	N/A	
PTC120 type temperature sensor	●	
PT100 type motor temperature sensor	PTC Sensors	
PTC110 type temperature sensor	N/A	
Screw in Discharge temperature sensor	● (251F)	● (230F)
IP-54 Terminal box	●	●
Crankcase oil heater	●	Δ
Compress chamber (Middle side) liquid inject port	●	Not Required
Motor side (Low side) liquid inject port	Not Required	Not Required
Economizer port	●	●
Oil cooling connection	●	●
Liquid injection oil cooling port	●	●
Oil drain valve	●	●
Oil level switch	Δ	Δ
Oil filter different pressure (ΔP) protector switch	Not Required	Not Required
Liquid injection expansion valve	N/A	Δ
Liquid injection solenoid valve	N/A	Δ
Safety Valve	● Internal	● Internal
Position sensor (Capacity control)	N/A	N/A
Slide fit motor	●	●
Starting type PWS	●	●
Starting type Start Delta	Δ	Δ
Jumper bars for DOL starting	●	Δ
Rubber mounting pads	●	●
Oil Separator	Intregal	Intregal
● (Standard) Δ (Option) N/A Not Applicable		

12 RefComp SRC Series

12.3 Model Number Nomenclature and Oil Type

See section 1 for the BITZER CS series model number nomenclature.

RefComp SRC-S-183-L-"4" or "Z" (Original Model Number)

SRC = Semi Hermetic Refrigerant Screw Compressor

S = S Series

183 = kW

L = Electrical Devices

L = 220 volt / **M** = 110 volt / **Y** = 24 volt

U = 220 volt UL / **V** = 110 volt UL

1 = 2 Step Capacity Control Model (134-XS-040 / SRC-XS)

2 = 2 Step Capacity Control Model (134-XS-050/060)

4 = 4 Step Capacity Control Model (134-S / SRC-S)

Z = Infinite Capacity Control Model (SRC-S)

RefComp 134-S-300-L-4 (New Model Number / 13 Models)

134 = R134A Semi Hermetic Refrigerant Screw Compressor

S = S Series

300 = Nominal Horsepower

L = Electrical Devices

L = 220 volt / **M** = 110 volt / **Y** = 24 volt

U = 220 volt UL / **V** = 110 volt UL

1 = 2 Step Capacity Control Model (134-XS-040 / SRC-XS)

2 = 2 Step Capacity Control Model (134-XS-050/060)

4 = 4 Step Capacity Control Model (134-S / SRC-S)

Z = Infinite Capacity Control Model (SRC-S)



Oil Types			
RefComp	SRC Series	R22 Oil	CPI4214-320
Bitzer	CSH Series	R22 Oil	CPI4214-320

12.4 Capacity Control

Capacity Control			
For the RefComp Screw Compressor 50%-100% Infinite Control			
Operation	Solenoid 14	Solenoid 15	Solenoid 16/19
Capacity Variation	De-energized	De-energized	Energized
Stationary	De-energized	De-energized	De-energized
50%	De-energized	Energized	De-energized
Start/stop	Energized	De-energized	De-energized

For the RefComp Screw Compressor-100% Minimum Step			
Operation	Solenoid 14	Solenoid 15	Solenoid 16/19
Capacity Variation	De-energized	De-energized	Energized
Stationary	De-energized	De-energized	De-energized
Minimum Capacity	Energized	De-energized	De-energized
Start/stop	Energized	De-energized	De-energized

For the Bitzer Screw Compressor-4-Step Capacity Control				
Operation	Solenoid 1	Solenoid 2	Solenoid 3	Solenoid 4
Start/stop	De-energized	De-energized	Energized	Pulsing
Capacity 25%	De-energized	De-energized	Energized	Pulsing
Capacity 50%	De-energized	Energized	De-energized	Pulsing
Capacity 75%	Energized	De-energized	De-energized	Pulsing
Capacity 100%	De-energized	De-energized	De-energized	Energized

For the Bitzer Screw Compressor-Infinite Capacity Control 25-100%		
Operation	Solenoid 3	Solenoid 4
Start/stop	Energized	De-energized
Loading	De-energized	Pulsing
Unloading	Pulsing	De-energized

12 RefComp SRC Series

12.4 Capacity Control (Continued)

See section 5 for additional information for the BITZER CS Capacity Control.

SRC-S-113/133/163/183/213/253/
303/353/413/463/503/553/603

SRC-S-255/285/305/755

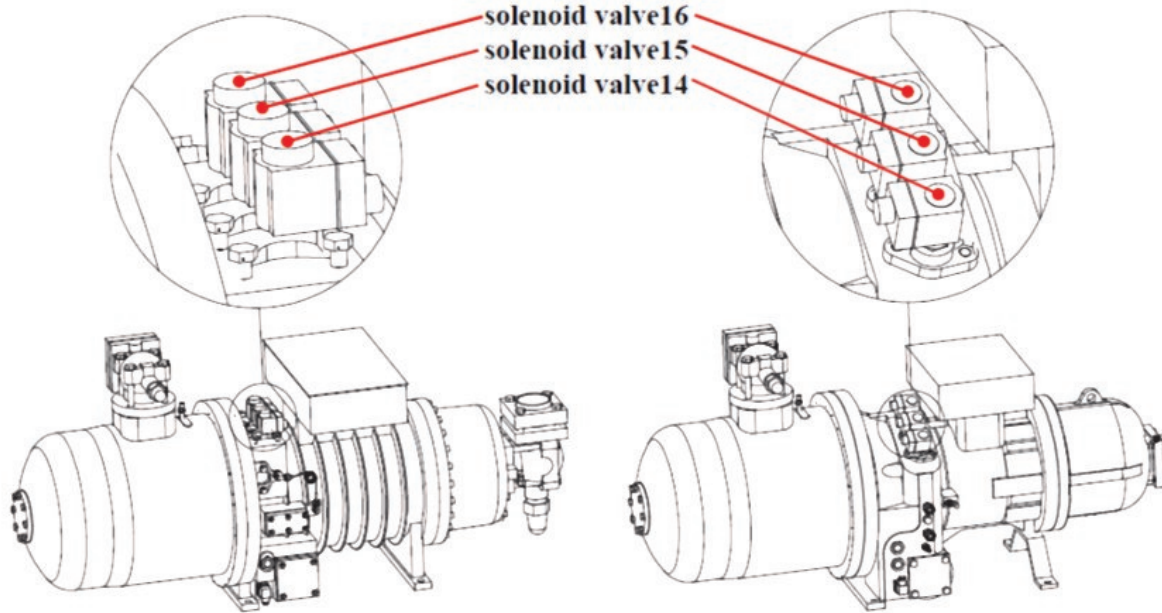

Stepped Control Solenoid Valves			
Load (capacity steps)	16	15	14
100%	Off	Off	Off
75%	On	Off	Off
50%	Off	On	Off
Minimum	Off	Off	On

Stepless Control 50-100%				
Phase	Regulation	16	15	14
1	Start-up	On	Off	Off
2	Loading >50%	Off	Off	On
3	Unloading to 50%	Off	On	Off
4	Modulation	Off	On/Off	On/Off
5	Unloading to 25%	On	Off	Off
6	Stop	On	Off	Off

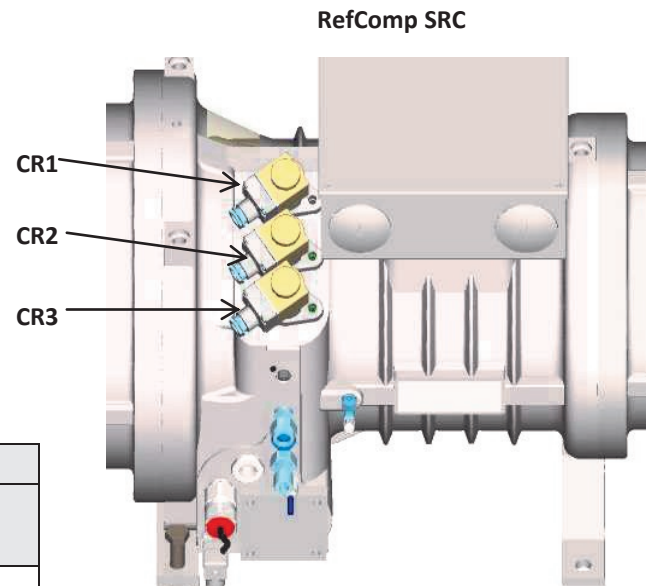

12.5 Module Types and Wiring

The control wiring for these compressors also has some differences.

The standard module included with the RefComp series is the INT69.

This module does not have phase protection.

Optional modules include the INT69Y and INT69HBY which have phase protection.

All three modules have power connected to L and N.

The INT69 has the control circuit connected to 11 and 14 where the optional modules have the control circuit wired thru M1 and M2.

The INT69 has the motor winding sensors and discharge gas temperature sensor wired in series to 1 and 2.

The optional modules have these wired via S1 and S2.

The Bitzer CSH and CSW series utilizes a SE-E1 electronic module as standard.

See section 6 for an overview of the SE-E1 module.

SRC Series Typical Terminal Box Wiring

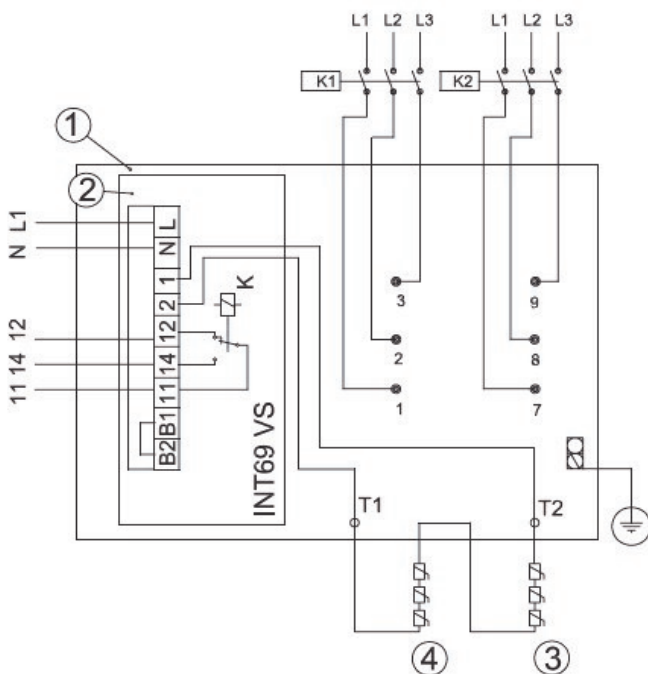

INT69 VS

KEY

- 1) Terminal box
- 2) Motor protection device INT 69 VS
- 3-4) Motor thermistors PTC
- L1-L2-L3) Power supply
- PW motor: K1 PW contactor 50%
- K2 PW contactor 50%, delay 0,6 sec.
- Y/Δ motor: K1-K3 start contactors (Y)
- K1-K2 run contactors (Δ)
- L1/N) Phase + neutral 230V-50/60Hz
- 11/14) Control circuit
- 1/2) Connection cables to thermistors
- K) Relay AC 250V, max. 5A, 300VA
- 12) Signal lamp (Temperature)
- B1/B2) Link for automatic reset

12 RefComp SRC Series

12.6 Dimensions, Weights and Connections

The RefComp SRC-S and SRC-XS have similar connection sizes

RefComp						
Model Number	Dimensions L x W x H (in)			Disch. Conn. (in)	Suction Conn. (in)	Shipping Weight (lb)
SRC-S-113 / SRC-XS-40	48	17	25	1 5/8	2 1/8	716
SRC-S-133 / SRC-XS-50	48	17	25	1 5/8	2 1/8	728
SRC-S-163 / SRC-XS-60	48	17	25	1 5/8	2 1/8	739
SRC-S-183	56	18	25	2 1/8	2 1/8	1124
SRC-S-213	56	18	25	2 1/8	2 1/8	1135
SRC-S-255	60	20	26	2 1/8	3 1/8	1290
SRC-S-285	60	20	26	2 1/8	3 1/8	1301
SRC-S-305	60	20	26	2 1/8	3 1/8	1378
SRC-S-353	64	21	30	3 1/8	3 5/8	1312
SRC-S-413	64	21	30	3 1/8	3 5/8	1609
SRC-S-463	64	21	30	3 1/8	3 5/8	1631
SRC-S-503	68	23	32	3 1/8	4 1/8	1709
SRC-S-553	68	23	32	3 1/8	4 1/8	2359
SRC-S-603	68	23	32	3 1/8	4 1/8	2403
Length of the RefComp Compressor is with the Suction and Discharge Service Valves						

Bitzer CSH						
Model Number	Dimensions L x W x H (in)			Disch. Conn. (in)	Suction Conn. (in)	Shipping Weight (lb)
CSH6553-50	43	22	22	1 5/8	2 1/8	671
CSH6563-60	43	22	22	1 5/8	2 1/8	693
CSH7553-70	53	22	24	2 1/8	3 1/8	1058
CSH7563-80	53	22	24	2 1/8	3 1/8	1076
CSH7573-90	53	22	24	2 1/8	3 1/8	1091
CSH8553-110	61	28	29	3 1/8	4 1/8	1749
CSH8563-125	61	28	29	3 1/8	4 1/8	1762
CSH8573-140	61	28	29	3 1/8	4 1/8	1784
CSH9553-180	72	28	33	3 1/8	4 1/8	2734
CSH9561-210	72	28	33	3 1/8	4 1/8	2778
CSH9573-240	72	28	33	3 1/8	4 1/8	2800
CSH9583-280	73	28	34	4 1/8	5.00	3043
CSH9593-300	73	28	34	4 1/8	5.00	3087
Compressor is with the Suction and Discharge Service Valves						

12.7 Outline Drawings

SRC-S-113/133/163

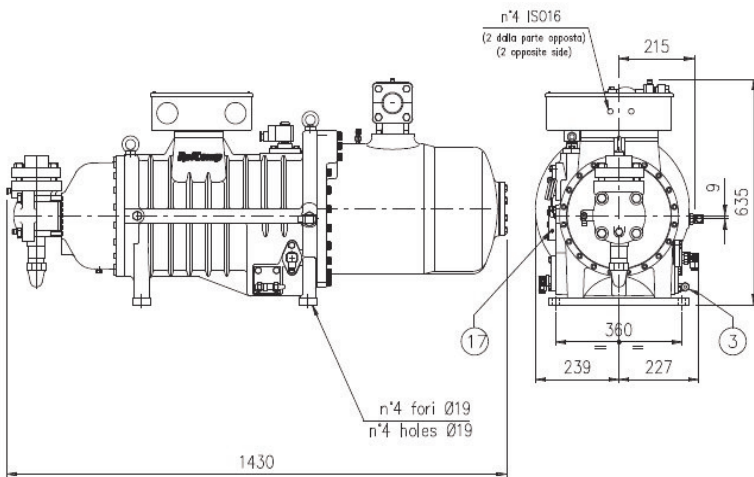
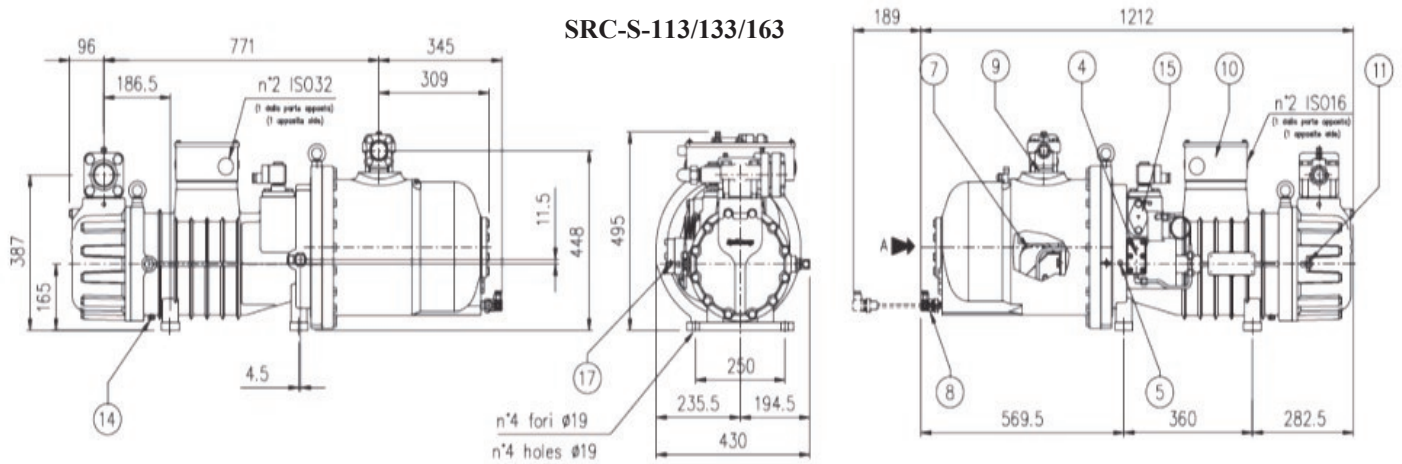

SRC-S-183/213

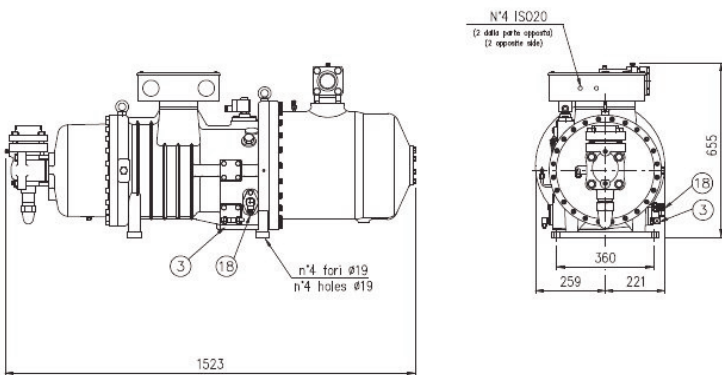
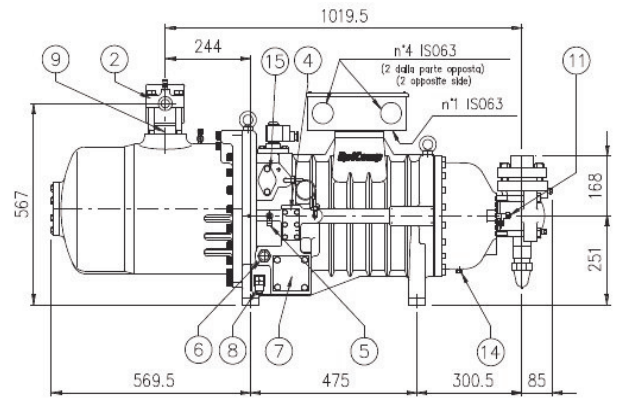

SRC-S-253/303

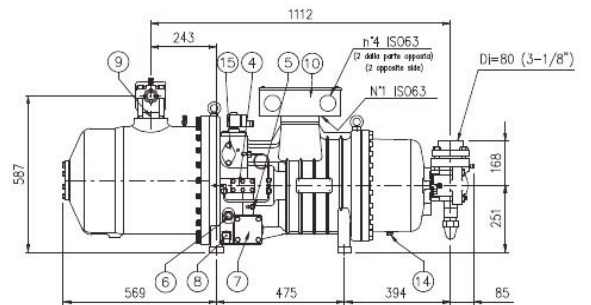

12 RefComp SRC Series

12.7 Outline Drawings (Continued)

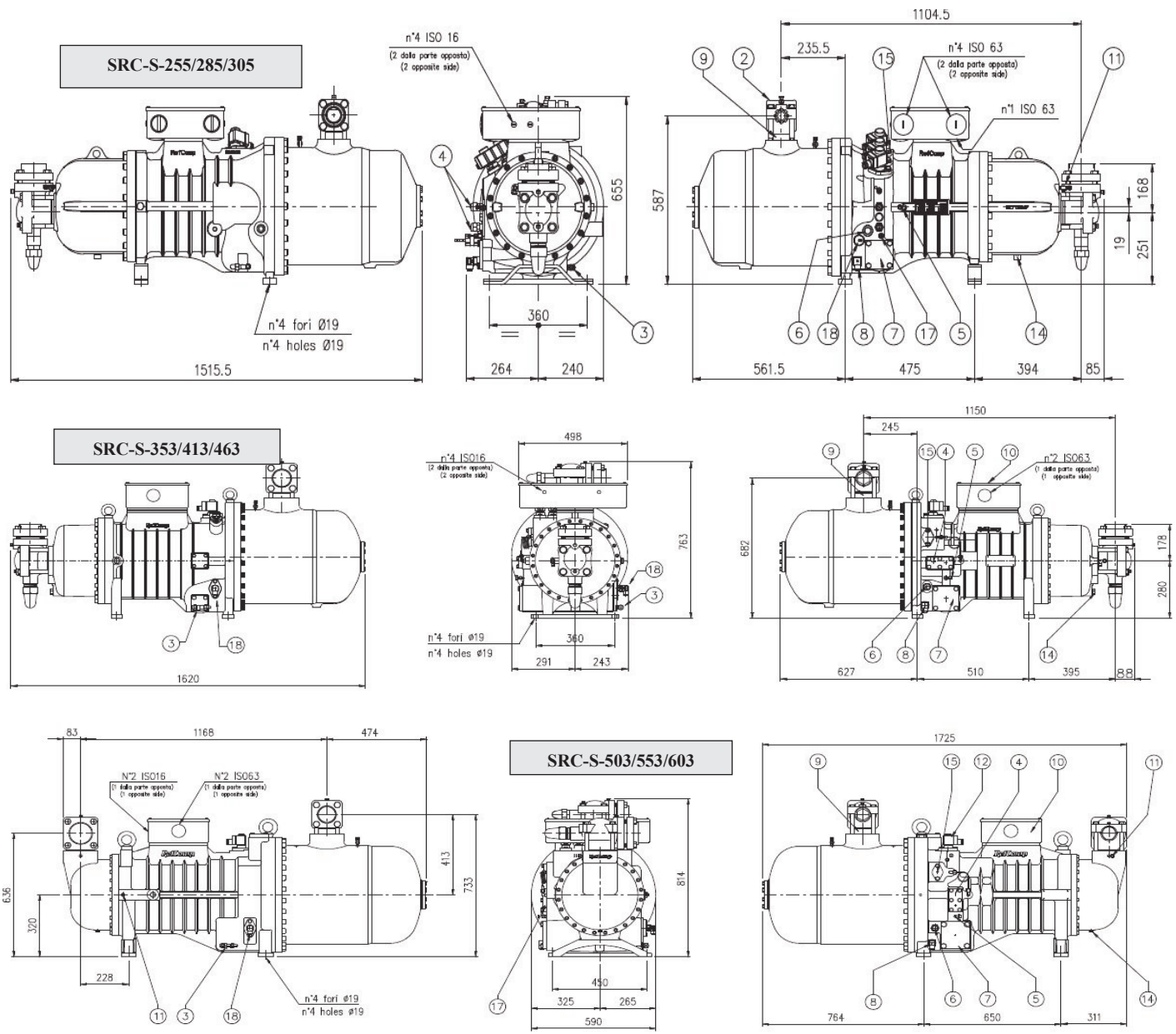

- 1 - Suction shut-off valve (optional)
- 2 - Discharge shut-off valve
- 3 - Oil fill / drain valve 3/8" SAE-Flare
- 4 - Oil cooler connections (optional)
- 5 - Oil pressure 1/4" SAE-Flare
- 6 - Oil sight glass
- 7 - Oil filter
- 8 - Crankcase heater
- 9 - Non return valve

- 10 - Electrical box
- 11 - Low pressure gas 1/4" SAE-Flare
- 12 - Solenoid valves for part-load operation
- 13 - High pressure gas 1/4" SAE-Flare
- 14 - Oil drain motor housing 1/4"-18 NPT
- 15 - Solenoid valve connection (step-less capacity control)
- 16 - Liquid injection/economizer connection (optional)
- 17 - Discharge temperature sensor 1/8" NPT (optional)
- 18 - Oil level control (optional)

13.1 Overview

Due to the various vintages with the ALS or PFS chillers, not all chillers may be the same. The below guidelines serve a general recommendation of what may have to be accomplished to remove a McQuay screw compressor and install a BITZER screw compressor.

Sizing Information:

For replacement compressor selection a capacity comparison of each compressor is given in section 3 ALS Chiller model numbers with respective compressor sizes can be found in the following pages.

Mechanical Information:

The suction and discharge connections are different between the McQuay and the BITZER compressors. The McQuay screw has the valves located on the top for the suction and on the side for the discharge.

The BITZER screw compressors have the valves located on the top for the CS65 thru CS85.

The suction valve connection is located on the end for the CS95.

The suction and discharge isolation valves as well as the discharge check valve can be removed from the existing piping, the BITZER compressors are supplied with suction and discharge service valves and an internal check valve.

It is recommended that a suction core drier be installed.

A small amount of new piping and various elbows will be required when converting to the BITZER compressor.

McQuay compressors utilized liquid motor cooling whereas the BITZER compressors do not. The liquid circuit piping which supplies motor cooling can be removed.

McQuay compressors also require an external oil separator, oil filter, solenoid valve, etc. BITZER compressors do not as the oil separator is integral to the compressor.

The existing oil separator and all associated components can be removed.

Wiring Information:

The control wiring for these compressors also has some differences.

The McQuay has a "safety chain" which is controlled by the PLC.

The BITZER screw compressor features the SE-E1 electronic module which provides oil-discharge gas temperature protection, motor winding temperature protection as well as phase protection.

This module must be incorporated into the safety chain.

There is an additional connection on the protection module at terminal 12. This can be used to indicate a general compressor failure.

The external reverse phase protection that was used for the McQuay must be removed as this function is incorporated into the BITZER screw protection module.

The last thing that needs to be checked is starting. In applications where reduced voltage starting is used the McQuay will have a Star Delta starter which is different than the BITZER screw compressor, which uses part winding starting for the CS65, 75 and 85 series. The CS95 series utilize Star Delta reduced voltage starting. Full voltage or direct on line starting is the same for both compressors.

The overload relay and the contactors must be checked for proper sizing.

Operational Information:

Capacity control slightly differs between the two compressors as the McQuay has (3) solenoids for capacity control while the BITZER has (4). Depending on the type or degree of capacity control required, the BITZER screw compressor can be controlled for 4 Step capacity control, 3 Step capacity control or infinite capacity control where only (2) of the solenoids are used. The different means of capacity control can be achieved without any modification to the compressor required.

13 McQuay ALS Series

13.2 Scope of Standard Delivery

Scope of Standard Delivery (as supplied by Manufacturer)	Bitzer CSH	McQuay ALS Series
Capacity control system : 4-Steps or Infinite Continuous (See Below)	No Modification Required	Δ 3 Step
25% to 100% Capacity Control	●	●
4 Step Capacity Control	●	N/A
Infinite Capacity Control	●	N/A
Solenoid coils for capacity control	●	●
Discharge Check Valve	● Internal	● External
Suction Coupling tube and/or Flange	N/A	N/A
Discharge Coupling tube and/or Flange	N/A	N/A
Suction Service Valve	●	Sys ●
Discharge Service Valve	●	Sys ●
Suction service valve location	Top	Top
Discharge service valve location	Top	End on Side
Oil Charge	●	Sep ●
Electronic Module (Rotation)	●	Δ
Electronic Module (Temperature)	●	●
PTC100 type temperature sensor	N/A	N/A
PTC120 type temperature sensor	●	●
PT100 type motor temperature sensor	PTC Sensors	N/A
PTC110 type temperature sensor	N/A	●
Screw in Discharge temperature sensor	● (251F)	
IP-54 Terminal box	●	●
Crankcase oil heater	●	Sep ●
Compress chamber (Middle side) liquid inject port	●	
Motor side (Low side) liquid inject port	Not Required	●
Economizer port	●	●
Oil cooling connection	●	
Liquid injection oil cooling port	●	
Oil drain valve	●	Sep ●
Oil level switch	Δ	Sep ●
Oil filter different pressure (ΔP) protector switch	Not Required	Sys ●
Liquid injection expansion valve	N/A	Sys ●
Liquid injection solenoid valve	N/A	Sys ●
Safety Valve	● Internal	Sys ●
Slide fit motor	●	No
Starting type PWS	●	Δ
Starting type Start Delta	Δ	Δ
Jumper bars for DOL starting	●	N/A
Rubber mounting pads	●	Sys ●
Oil Separator	Integral	External

● (Standard) Δ (Option) N/A Not Applicable Sys ● (System Supplied) Sep ● (Separator Supplied)

13.3 McQuay Model Numbers and Oil Type

McQuay Compressor Part Numbers				
Description	Volt	Part No #1	Part No #2	Part No #3
Size 155	208/230	74166501	74165501	MR350310516
Size 155	460	74166503	74165503	MR350310517
Size 155	575	74166504	74165504	MR350310519
Size 167	208/230	74166601	74165601	MR350310623
Size 167	460	74166603	74165603	MR350310624
Size 167	575	74166604	74165604	MR350310626
Size 175	208/230	74166701	74165701	MR350310730
Size 175	460	74166703	74165703	MR350310731
Size 175	575	74166704	74165704	MR350310733

McQuay Model	Oil Charge (Separator)	Oil Type R22
Size 155	3 gallons	Planetelf ACD68AW or ICI RL68
Size 167	3 gallons	
Size 175	3 gallons	

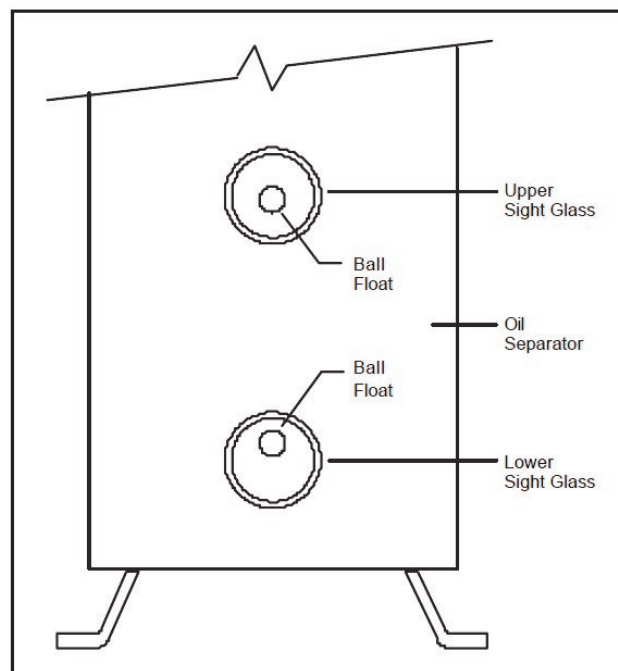

The oil level while operating under any condition, the bottom sight glass should be full of oil.

13 McQuay ALS Series

13.3 Model Numbers (Continued)

Unit Model Vintage "A"	Comp 1	Comp 2	Comp 3	Comp 4
ALS070A	Size 155			
ALS080A	Size 167			
ALS090A	Size 175			
ALS100A	Size 175			
ALS125A	Size 155	Size 155		
ALS140A	Size 155	Size 167		
ALS141A	Size 155	Size 155		
ALS150A	Size 155	Size 167		
ALS155A	Size 167	Size 167		
ALS170A	Size 167	Size 175		
ALS171A	Size 167	Size 167		
ALS175A	Size 167	Size 175		
ALS185A	Size 175	Size 175		
ALS186A	Size 167	Size 175		
ALS190A	Size 167	Size 175		
ALS195A	Size 175	Size 175		
ALS204A	Size 175	Size 175		
ALS205A	Size 155	Size 155	Size 167	
ALS206A	Size 175	Size 175		
ALS218A	Size 175	Size 175		
ALS220A	Size 155	Size 167	Size 167	
ALS235A	Size 167	Size 167	Size 167	
ALS250A	Size 167	Size 167	Size 167	
ALS265A	Size 167	Size 175	Size 175	
ALS280A	Size 175	Size 175	Size 175	
ALS300A	Size 155	Size 155	Size 167	Size 167
ALS315A	Size 155	Size 167	Size 167	Size 167
ALS330A	Size 167	Size 167	Size 167	Size 167
ALS340A	Size 167	Size 167	Size 167	Size 175
ALS360A	Size 167	Size 167	Size 175	Size 175
ALS370A	Size 167	Size 175	Size 175	Size 175
ALS380A	Size 175	Size 175	Size 175	Size 175
ALS425A	Size 175	Size 175	Size 175	Size 175

13.3 Model Numbers (Continued)

Unit Model Vintage "B"	Comp 1	Comp 2	Comp 3	Comp 4
ALS125B	Size 155	Size 155		
ALS140B	Size 155	Size 167		
ALS155B	Size 167	Size 167		
ALS170B	Size 167	Size 175		
ALS175B	Size 167	Size 175		
ALS185B	Size 175	Size 175		
ALS195B	Size 175	Size 175		
ALS204B	Size 175	Size 175		
ALS220B	Size 155	Size 167	Size 167	
ALS235B	Size 167	Size 167	Size 167	
ALS250B	Size 167	Size 167	Size 175	
ALS265B	Size 167	Size 175	Size 175	
ALS280B	Size 175	Size 175	Size 175	
ALS300B	Size 155	Size 155	Size 167	Size 167
ALS315B	Size 155	Size 167	Size 167	Size 167
ALS330B	Size 167	Size 167	Size 167	Size 167
ALS340B	Size 167	Size 167	Size 167	Size 175
ALS360B	Size 167	Size 167	Size 175	Size 175
ALS370B	Size 167	Size 175	Size 175	Size 175
ALS380B	Size 175	Size 175	Size 175	Size 175
ALS425B	Size 175	Size 175	Size 175	Size 175

Unit Model Vintage "C"	Comp 1	Comp 2	Comp 3	Comp 4
ALS141C	Size 155	Size 155		
ALS150C	Size 155	Size 167		
ALS171C	Size 167	Size 167		
ALS186C	Size 167	Size 175		
ALS190C	Size 167	Size 175		
ALS200C	Size 175	Size 175		
ALS206C	Size 175	Size 175		
ALS218C	Size 175	Size 175		
ALS245C	Size 155	Size 167	Size 167	
ALS260C	Size 167	Size 167	Size 167	
ALS270C	Size 167	Size 167	Size 175	
ALS275C	Size 167	Size 175	Size 175	
ALS295C	Size 175	Size 175	Size 175	
ALS325C	Size 155	Size 155	Size 167	Size 167
ALS335C	Size 155	Size 167	Size 167	Size 167
ALS350C	Size 167	Size 167	Size 167	Size 167
ALS365C	Size 167	Size 167	Size 167	Size 175
ALS375C	Size 167	Size 167	Size 175	Size 175
ALS385C	Size 167	Size 175	Size 175	Size 175
ALS400C	Size 175	Size 175	Size 175	Size 175
ALS420C	Size 175	Size 175	Size 175	Size 175

13 McQuay ALS Series

13.4 Dimensions and Connection Sizes

McQuay Dimensions			
Model	Length	Height	Width
Size 155	33"	21"	23"
Size 167	33"	21"	23"
Size 175	33"	21"	23"
Without Service Valves			

Bitzer CSH Dimensions			
Model	Length	Height	Width
CSH7563-80	53"	23"	22"
CSH7573-90	53"	23"	22"
CSH7583-100	53"	23"	22"
CSH7593-110	54"	23"	22"
CSH8553-110	60"	28"	27"
CSH8563-125	60"	28"	27"
With Service Valves			

McQuay Model	Suction Connection	Discharge Connection
Size 155	2-5/8"	
Size 167	2-5/8"	
Size 175	2-5/8"	

CSH Model	Suction Valve	Discharge Valve
7563-80	3-1/8"	2-1/8"
7573-90	3-1/8"	2-1/8"
7583-100	3-1/8"	2-1/8"
7593-110	3-1/8"	2-1/8"
8553-110	4-1/8"	3-1/8"
8563-125	4-1/8"	3-1/8"

13.5 Capacity Control

See section 5 for the capacity solenoid layout for the BITZER CS screw compressor.

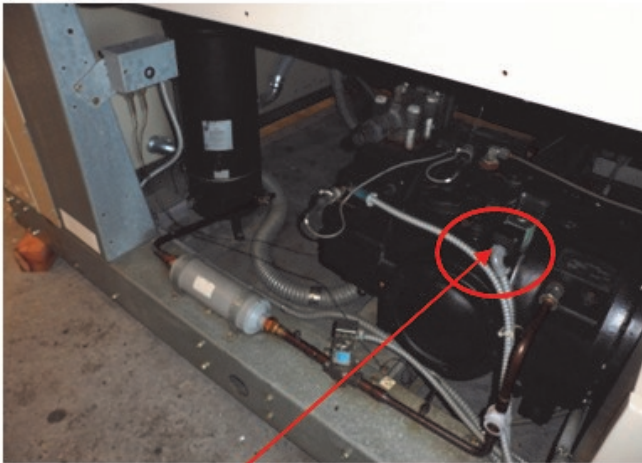

Top Solenoid = Feed

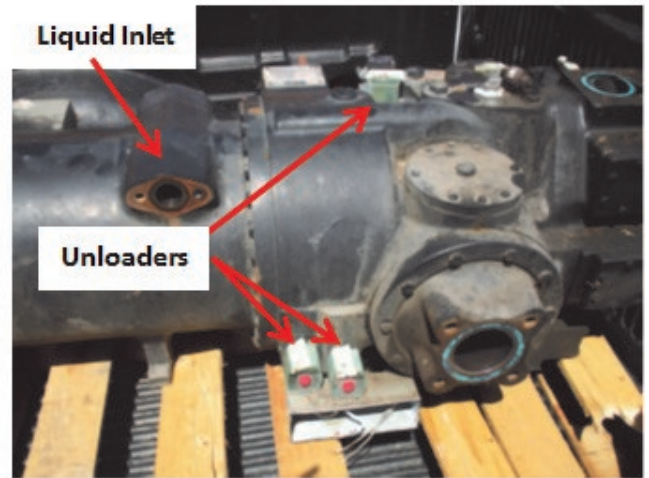

Bottom Rear Solenoid = Vent

Bottom Front Solenoid = Vent

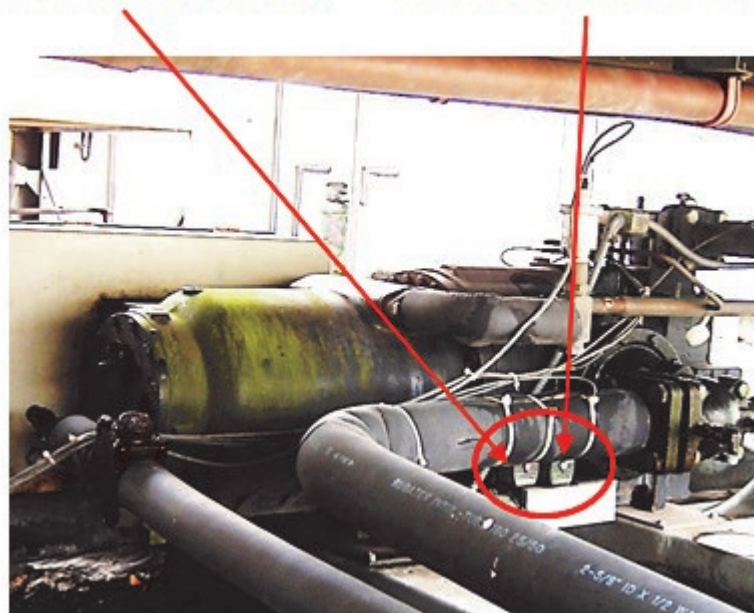

COMPRESSOR LOADING %	COMPRESSOR UNLOADING SOLENOID STATUS		
	Top Solenoid	Bottom Front Solenoid	Bottom Rear Solenoid
100%	Energized	Off	Energized
75%	Energized	Energized	Off
50%	Off	Off	Energized
25%	Off	Energized	Off

13 McQuay ALS Series

13.5 Capacity Control (Continued)

McQuay Solenoid Coils:

The ALS unit screw compressors are equipped with 3 solenoids to control compressor unloading. The solenoids are controlled by the Micro Tech outputs. See unit wiring diagrams. The solenoids are energized at various compressor load conditions as indicated in the table above on the previous page.

Location of the solenoids is as follows:

The top solenoid is on top of the compressor near the discharge end.

The bottom solenoids are on the lower side of the compressor on the opposite side from the terminal box.

The bottom front solenoid is the one closest to the discharge end of the compressor.

The bottom rear solenoid is the one closest to the motor end of the compressor.

If the compressor is not loading properly, check the solenoids to see if they are energized per the chart shown on previous page.

BITZER Solenoid Coils:

The #4 unloading coil was connected to wires 183 and 184 (fully load the compressor).

The #1 unloading coil was connected to wires 185 and 143 (load the compressor to 75%).

Depending on the chiller vintage, the wire identifications may change.

Typically, the McQuay unloaded two coils at a time while the BITZER only needs one.

For the Bitzer Screw Compressor-4-Step Capacity Control				
Operation	Solenoid 1	Solenoid 2	Solenoid 3	Solenoid 4
Start/stop	De-energized	De-energized	Energized	Pulsing
Capacity 25%	De-energized	De-energized	Energized	Pulsing
Capacity 50%	De-energized	Energized	De-energized	Pulsing
Capacity 75%	Energized	De-energized	De-energized	Pulsing
Capacity 100%	De-energized	De-energized	De-energized	Energized

For the Bitzer Screw Compressor-Infinite Capacity Control 25-100%		
Operation	Solenoid 3	Solenoid 4
Start/stop	Energized	De-energized
Loading	De-energized	Pulsing
Unloading	Pulsing	De-energized

13.5 Capacity Control (Continued)

With the New Wiring:

When the McQuay needs 100%, it will energize #4 only and fully load the BITZER CS compressor.

When the McQuay needs 75%, it will energize # 4 and # 1 which will actually keep the BITZER at the same load it was at.

When the McQuay needs 50%, neither of the coils will energize and the compressor will slowly unload itself.

When the McQuay needs 25%, # 1 will energize which will energize # 1 and the compressor will slowly un-load itself.

An option for capacity control would be to install a “stand alone” capacity controller. See BITZER US Technical Bulletin TB-0039 for further information.

Below is a standard diagram of the wiring for McQuay capacity control:

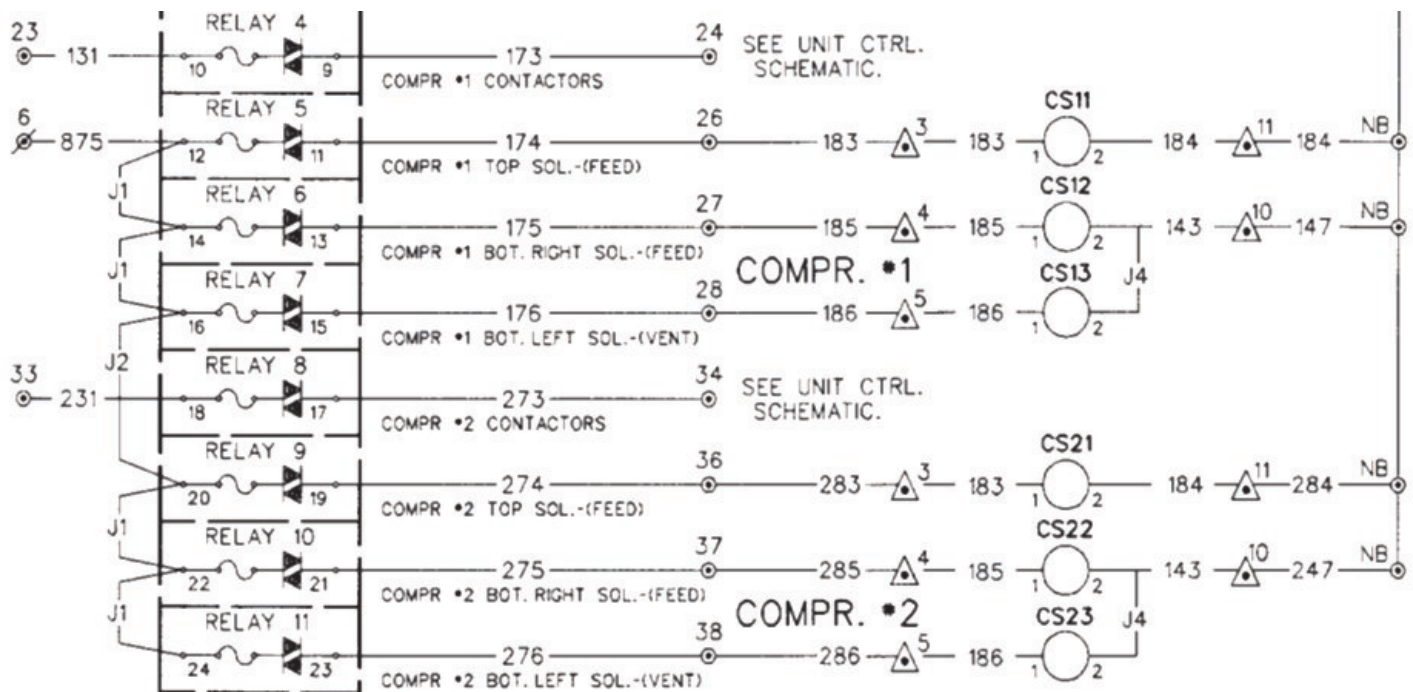

For Infinite Capacity control on the BITZER CS compressor, 2 solenoids will be used. # 4 solenoid is for 100% while # 3 is for 25% capacity control.

Depending on actual operating conditions, the BITZER CS screw compressor may be limited to 50% capacity control where # 2 coil would be used as the minimum capacity.

Consult the BITZER software to determine the minimum capacity at the desired operating parameters.

13 McQuay ALS Series

13.6 Oil Separator and Piping Components

The oil separator and components used on the McQuay compressor can be removed and discarded. BITZER CS series screw compressors feature an integral flanged on oil separator. When the McQuay external oil separator and components are removed, this will free up space for the installation of the BITZER.

After removal, the wires used on the oil solenoid, oil pressure and oil sensor (OLS) can be jumper'ed together.

Wire terminals 807, 808 and 839.

The existing crankcase heater wires can be used to power the BITZER crankcase heater.

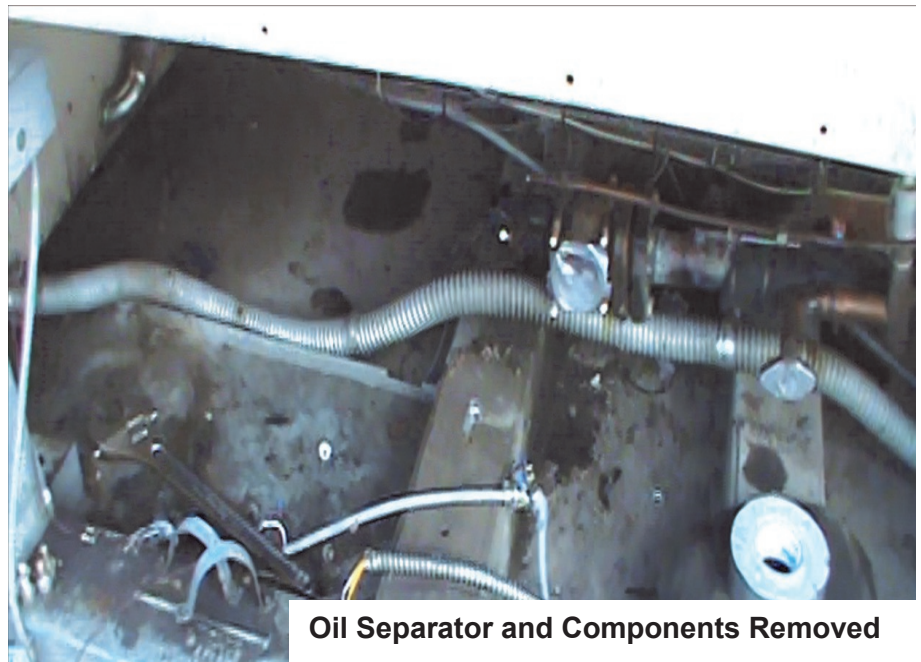
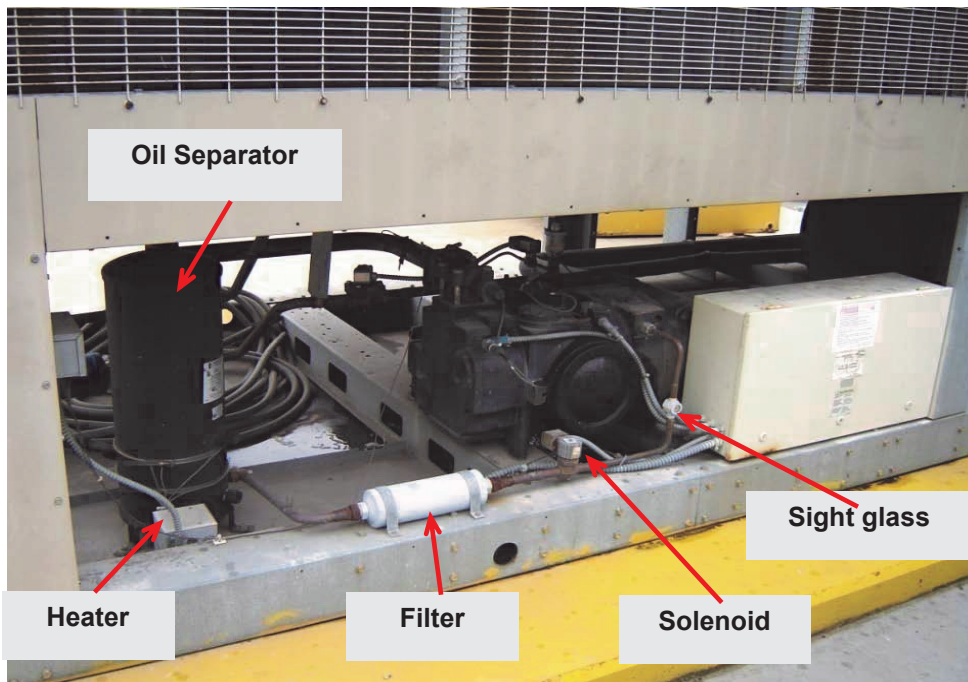

13.7 High Pressure Switch

The existing high pressure switch used on the McQuay compressor can be installed onto the BITZER CS compressor.

There are two HP connections on the BITZER CS compressor.

The top fitting is for “system” pressure (2-HP) while the bottom or lower fitting is for the “compressor” pressure (1-HP).

The internal discharge check valve is located between these two ports.

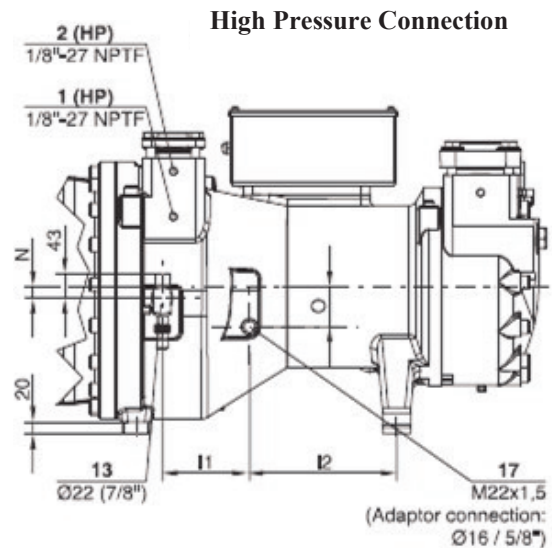
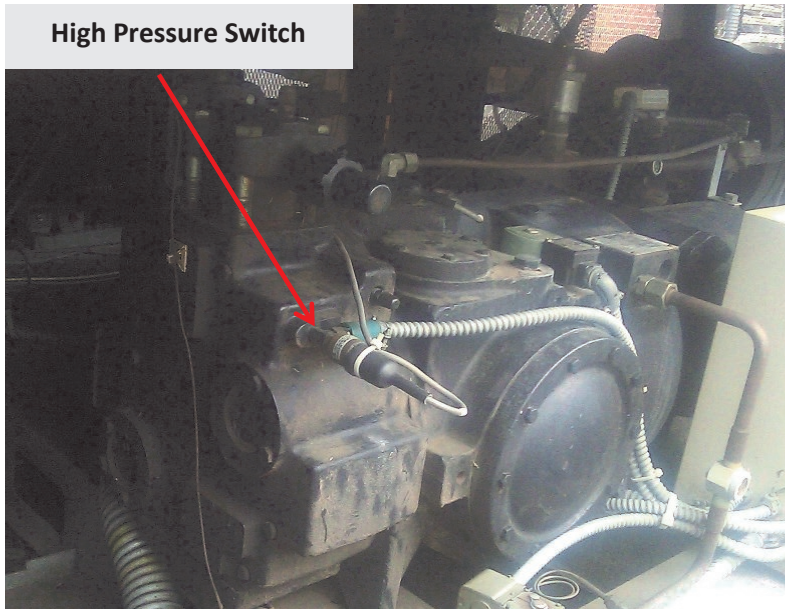

Existing Controls:

The wiring used for the oil solenoid, oil pressure and oil sensor were removed.

These wires were jumper'ed together.

On the above retrofit example, these wires were identified as 807, 808 and 809 on the wiring schematics.

Old Existing Overload:

A resistor of 2,000 Ohms was added between the thermistor / overload wires that were used with the McQuay to simulate that the compressor was still in place.

The new SE-E1 electronic module used on the BITZER CS compressor will replace the safety that the McQuay PLC was performing in terms of functionality.

13 McQuay ALS Series

13.8 Installation Example

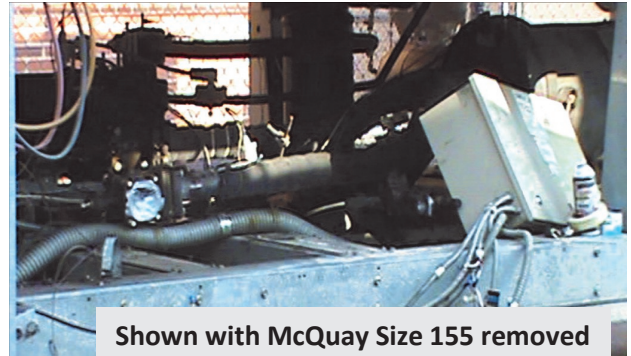

Shown with McQuay Size 155 removed

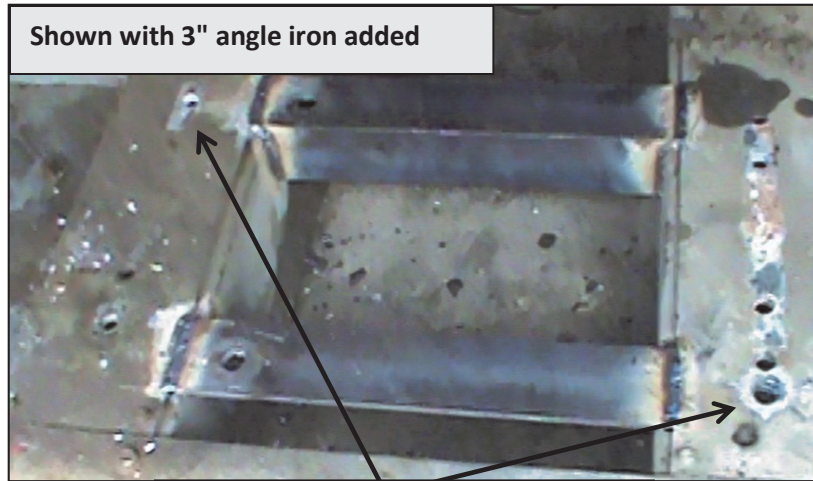

Shown with 3" angle iron added

Existing mounting holes from McQuay

Re-used (2) existing mounting holes from McQuay and (2) New holes

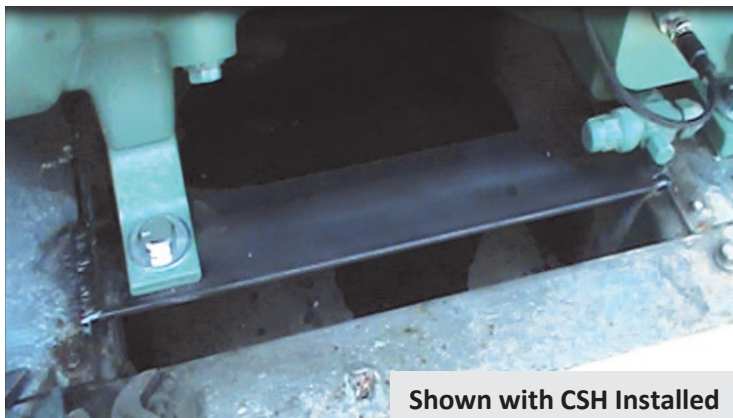
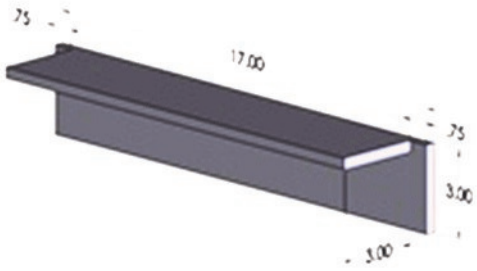

Shown with CSH Installed

13.9 Piping Example

After the McQuay compressor, oil separator and components have been removed and additional supports have been added to mount the BITZER compressor, piping modifications will have to be accomplished. There will actually be less piping resulting in lower possibility of refrigerant leakage once the BITZER is installed and piped in.

The suction piping needed (2) elbows to come up from the evaporator outlet piping that was already in place and a suction core filter drier was installed into the piping which required an additional elbow.

The discharge piping needed (2) elbows before it then led slightly down as it came towards the condenser inlet. (2) elbows were required to pipe into the condenser inlet which was originally the oil separator outlet line which had been removed. This was accomplished so that any condensed refrigerant in the discharge line would be trapped rather than be allowed to migrate back to the compressor.

The following pictures show a replacement. Note, not all applications may require the same type of mounting and piping layout.

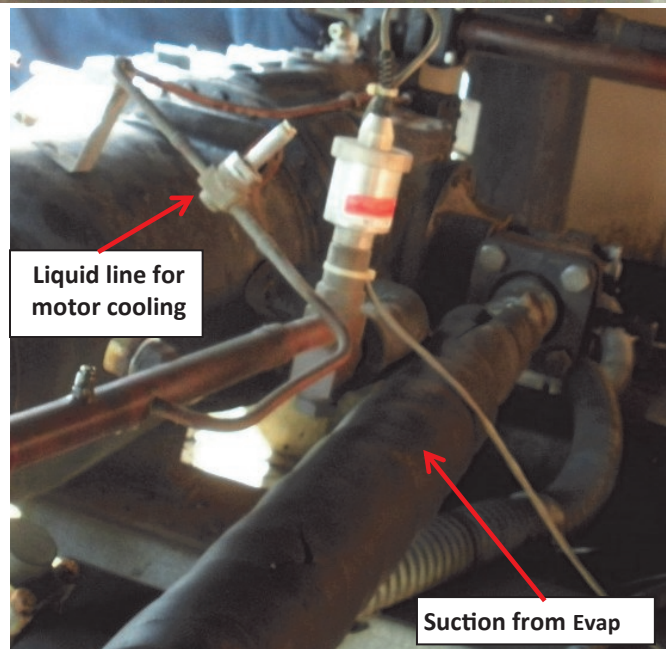
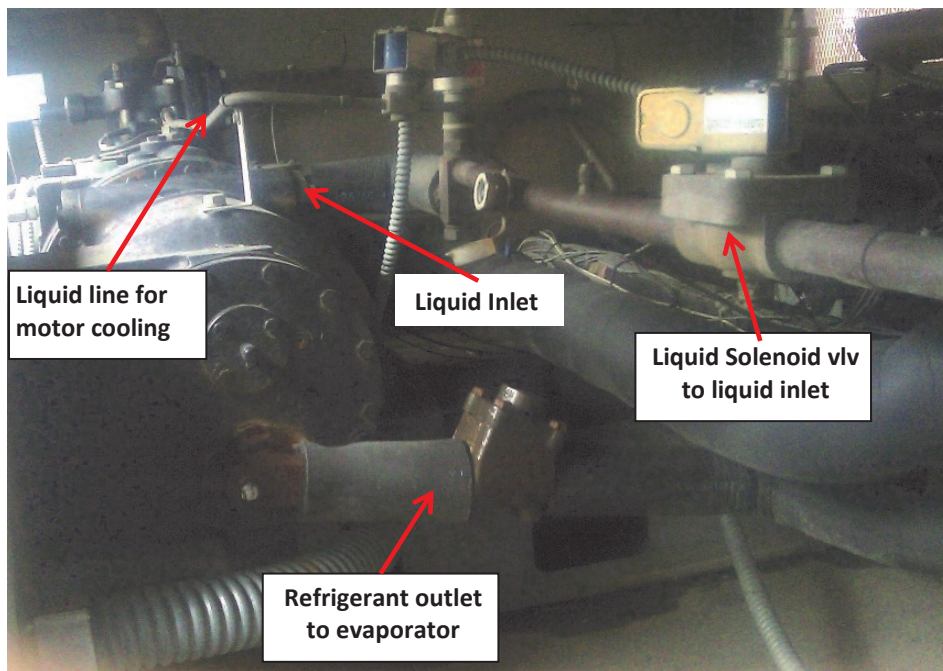

13 McQuay ALS Series

13.9 Piping Example (Continued)

Because the BITZER compressor does not require liquid injection motor cooling, the liquid line and TXV were reconnected before setting the new compressor in place by brazing two elbows together and a straight run into the evaporator



Suction connection shown
with two new elbows
Discharge connection
similar to suction

13.9 Piping Example (Continued)

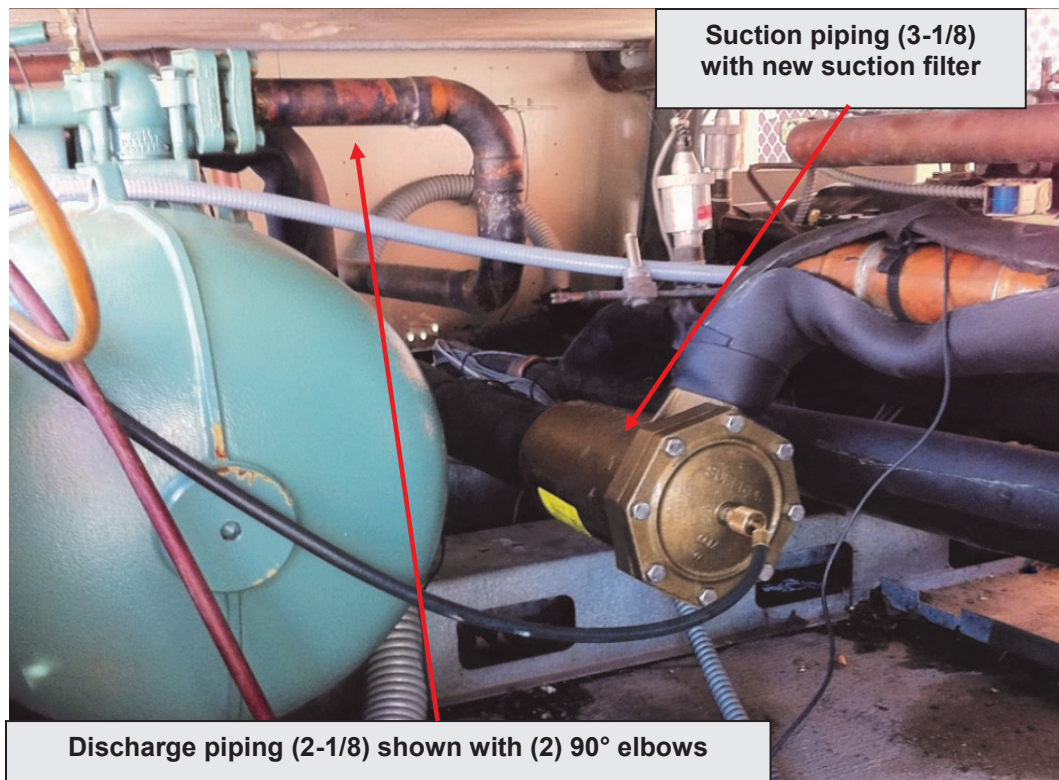

If the existing has had a check valve installed in the piping to prevent liquid refrigerant from draining back to the compressor due to a power issue, the check valve can be removed.

The purpose of this check valve is to prevent liquid back flow to the compressor motor in the event of a power failure. Units without this check valve on a power failure will fill the motor and compressor with liquid refrigerant as the compressor is below the evaporator level.

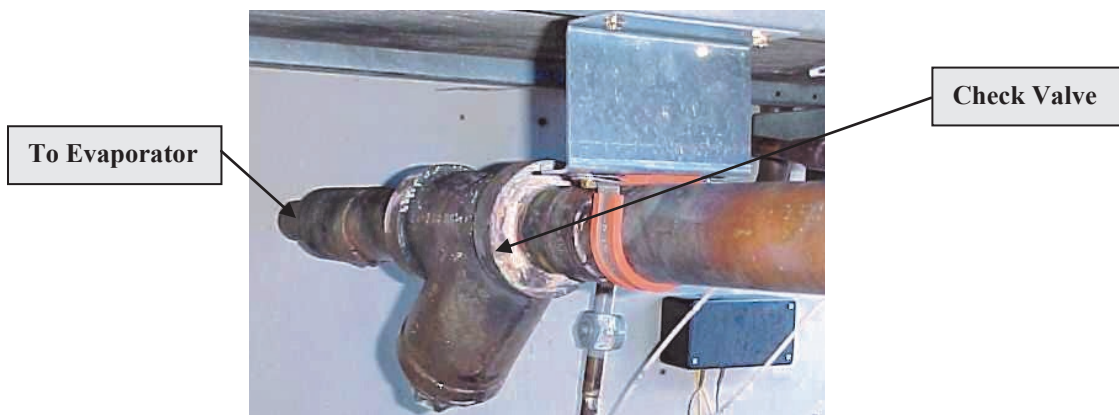

If the existing ALS chiller has had gate failures, the possibility exists that some of the broken pieces may end up in the evaporator on the suction baffle in a PFS unit and in the suction line and possibly the suction end of the evaporator on an ALS unit. On the ALS units, as a minimum, the suction pipe must be removed and cleaned before installing a new compressor. (This can be accomplished very easily.) In addition, if there was ever a motor failure, seizure or gate failure, a suction core filter housing was required to be installed.

It is recommended to install a suction core filter drier or to re-use an existing drier when installing a BITZER CS compressor which aids in cleaning a circuit and also preventing system debris from entering the new compressor.

13 McQuay ALS Series

13.10 Electrical Information

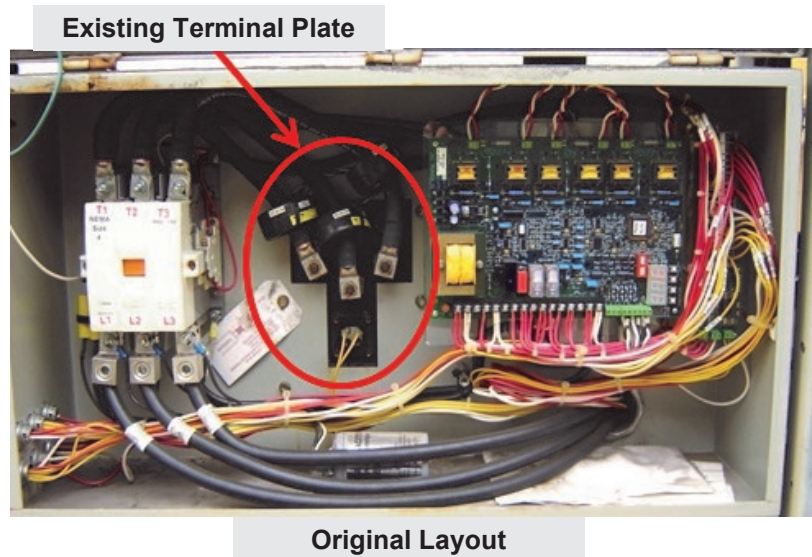

A 7" x 9" mounting plate with a gasket was used to cover over the existing access in the terminal box when the McQuay compressor was removed

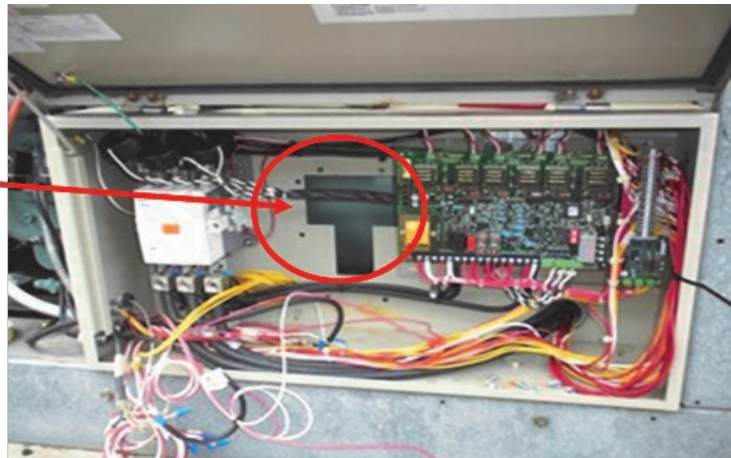

Power Leads:

The power wire was run through the conduit up to the terminal box. (6) cables were used. (2) for each leg so thicker cable was not required.

Compressor Motor Protection:

The McQuay compressors are supplied with two types of motor protection. Solid state electronic overloads mounted in the control box sense motor current within 2% of the operating amps. The "must trip" amps are equal to 140% of the unit nameplate compressor RLA. The "most hold" amps equal to 125% of the unit nameplate. A trip of these overloads can result from the unit operating outside of normal conditions. Repeat overloads are manual reset and must be reset at the overload as well as through the Micro Tech.

The compressors also have a solid state Guard circuit that provides motor over temperature protection. This circuit has an automatic reset but must be reset through the Micro Tech.

13.10 Electrical Information (Continued)

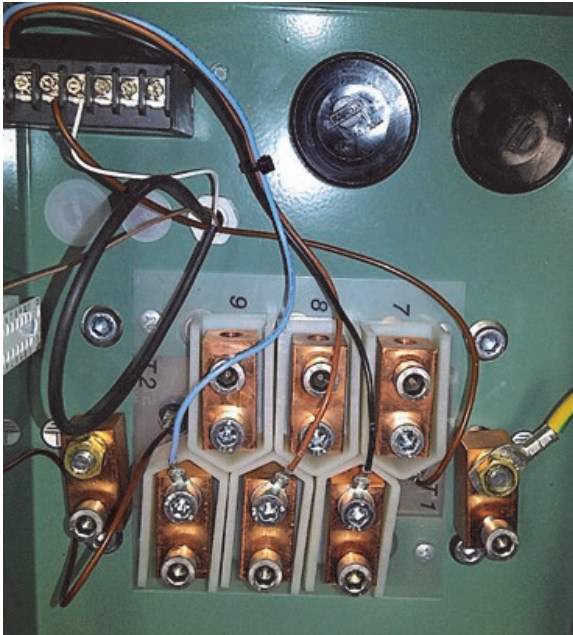

CS75 Series Terminal Box

BITZER CS series screw compressors utilize Standard Part Winding or Direct On Line starting on 35 thru 140 horsepower compressors which is the same as the McQuay screw compressors. BITZER 160 thru 320 horsepower utilize Star Delta type starting. See section 6 for additional information of the SE-E1 module.



SE-E1 Electronic Module

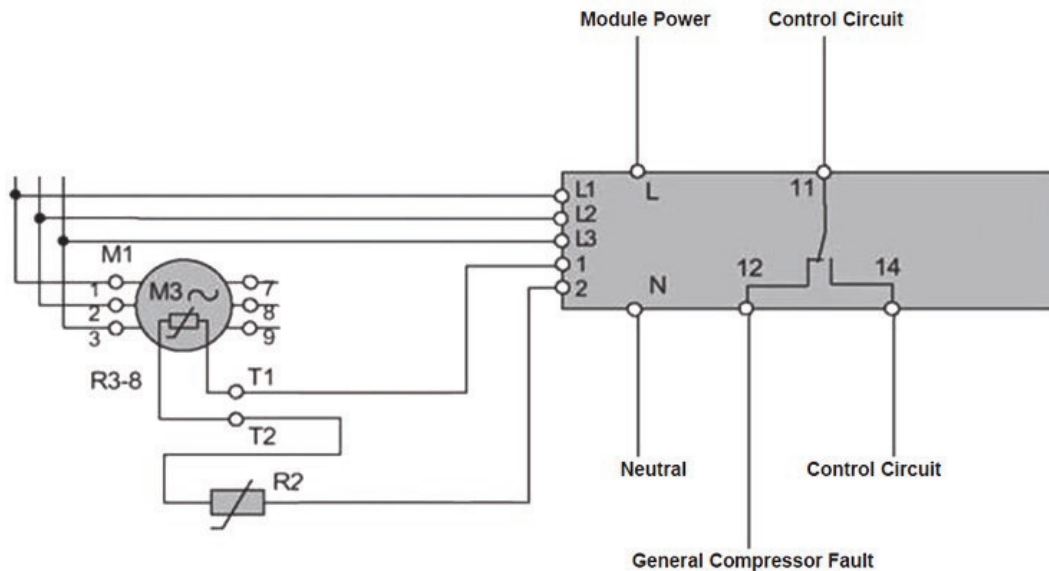

13 McQuay ALS Series

13.11 Component Operation

Compressor Short Cycling Protection:

The Micro Tech contains logic to prevent rapid compressor restarting. Excessive compressor starts can be hard on starting components and create excessive motor winding temperatures. The anti-cycle timers are set for a 5 minute stop to start cycle and a 15 minute start to start cycle. Both of these parameters are adjustable through the Micro Tech, however, BITZER CS screw compressors are recommended with the same type of timing sequence. Power wire was run through the conduit up to the terminal box. (6) cables were used. (2) for each leg so thicker cable was not required.

Description of the McQuay Electronic Expansion Valve:

The electronic expansion valve is located adjacent to the compressor. The refrigerant is piped to first pass through the electronic expansion valve, then through the motor housing cooling the motor before going to the evaporator. Refer to figure 32, ALS piping schematic.

All ALS chillers are factory set between 8°F (4.5°C) and 12°F (6.6°C) superheat at 75% to 100% load and between 6°F (3.3°C) and 10°F (5.6°C) below 75% load. The superheat is controlled by the microprocessor and is not adjustable.

A feature of the electronic expansion valve is maximum pressure setting (MOP). This setting limits the load on the compressor during start-up periods where high return evaporator water temperature may be present. The valve will limit the maximum suction pressure at start-up to approximately 85 psig. The valve will maintain evaporator pressure close to 85 psig until the evaporator water temperature decreases to approximately 55°F to 60°F (12.7°C to 15.6°C).

When the circuit starts, the valve opens as soon as the evaporator pressure decreases to 40 psig. At the end of the cooling cycle, the valve closes causing the system to pumpdown. The valve closes at the rate of approximately 55 steps per second from full open to full closed in approximately 14 seconds. The valve closing pumpdown will occur in approximately 20-30 seconds after the pumpdown switch is moved to the "pumpdown and stop" position.

13.12 McQuay Dimensional Data

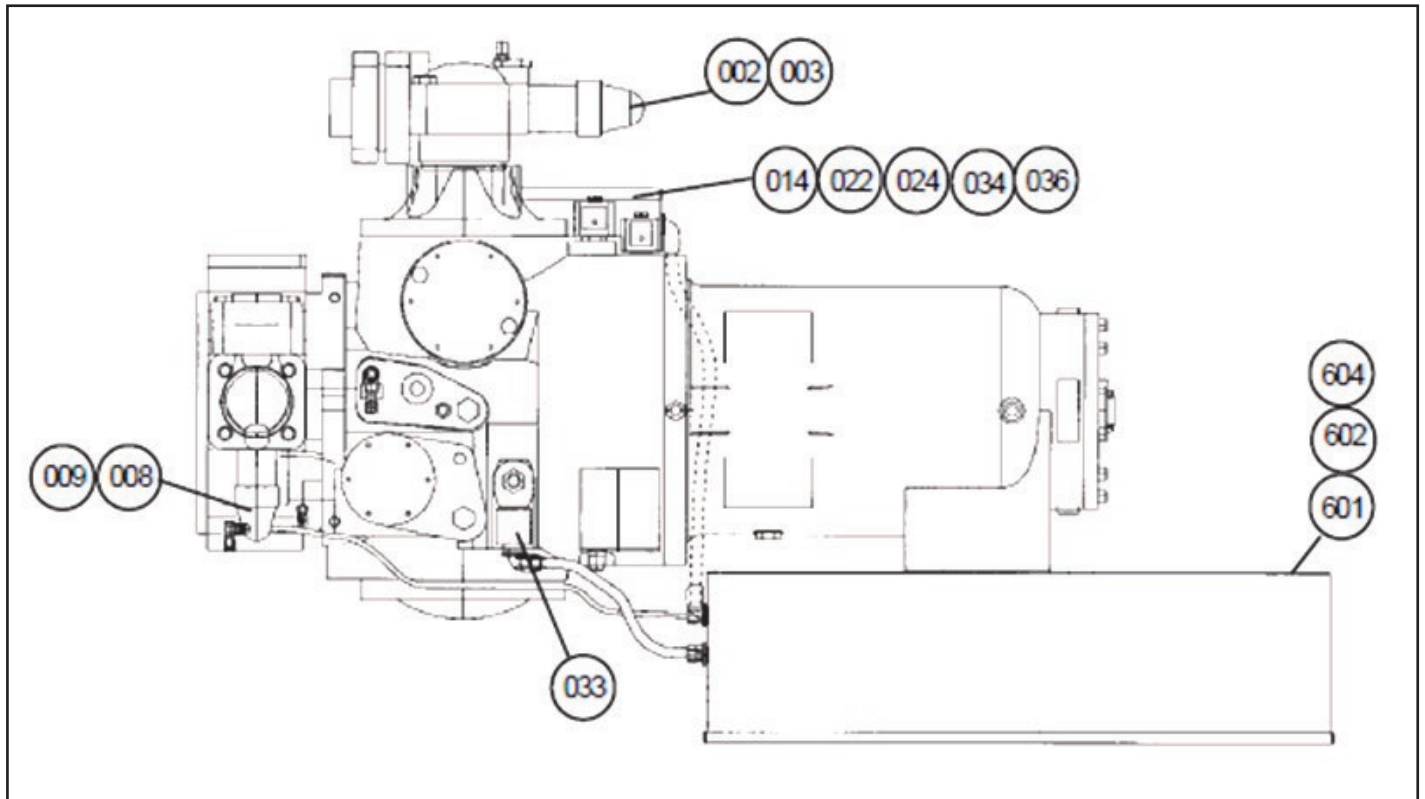

Ref #	Description
2	Shut off valve, OSD Suction
3	Suction Gasket
8	Shut off valve, Discharge
9	Discharge Gasket
14	Crankcase Heater
18	High Pressure Switch. Open 400 / Close 300
22	Junction Box
24	Cover, Junction Box
33	Solenoid Coil with Electrical Box
34	Solenoid Coil with Flag Connection (CS12, CS13)
36	J Box Gasket
601	Solid State Starter SSK (208/230V)
601	Solid State Starter SSK (380, 460 575V)
602	Starter Box Gasket
604	Gasket

14 York YCAS and YCWS Series

14.1 Overview

Due to the various vintages with these chillers, not all chillers may be the same. The below guidelines serve a general recommendation of what may have to be accomplished to remove a York screw compressor and install a BITZER CS screw compressor.

Sizing Information:

For replacement compressor selection a capacity comparison of each compressor is given in section 3. York YCAS and YCWS Revision "F" Chiller model numbers with respective compressor sizes can be found on the pages to follow.

Mechanical Information:

The suction and discharge connections are different between the DXS series and the BITZER compressors. The York screw has the valves located on the ends of the compressor for both the suction and discharge. The BITZER screw compressors have the valves located on the top for the CS65 thru CS85. The suction valve connection is located on the end for the CS95. The suction and discharge isolation valves as well as the external discharge check valve can be removed from the existing piping, the BITZER compressors are supplied with suction and discharge service valves and an internal check valve.

It is recommended that a suction core drier be installed.

A small amount of new piping and various elbows will be required when converting to the BITZER compressor.

York DXS series compressors require two identical external oil separators which will also be required to be removed. BITZER CS series compressors feature an integral flanged on oil separator.

York YCAS and YCWS chillers may also have economizer circuits on each compressor. Depending on the capacity required, when selecting the BITZER replacement compressor, these economizer circuits including the heat exchangers can also be removed.

Wiring Information:

The control wiring for these compressors also has some differences.

The York DXS compressors feature a motor protection module which provides temperature protection as well as phase to phase current imbalance, overcurrent, under current and phase rotation. The module is mounted in the control panel.

The BITZER screw compressor features the SE-E1 electronic module which provides oil-discharge gas temperature protection, motor winding temperature protection as well as phase protection.

This module must be incorporated into the safety chain.

There is an additional connection on the protection module at terminal 12. This can be used to indicate a general compressor failure.

The SE-E1 electronic module installed inside of the terminal box is pre-wired. Module power and control circuit will need to be hooked into the module.

The last thing that needs to be checked is starting. In applications where reduced voltage starting is used the York chillers will have a Star Delta starter which is different than the BITZER screw compressor, which uses part winding starting for the CS65, 75 and 85 series. The CS95 series utilize Star Delta reduced voltage starting. Full voltage or direct on line starting is the same for both compressors.

The overload relay and the contactors must be checked for proper sizing.

Operational Information:

Capacity control differs slightly between the two compressors as the York DXS compressors feature a 3 way proportional capacity control valve regulated via pressure control while the BITZER has (4) flanged solenoid coils for capacity control.

Depending on the type or degree of capacity control required, the BITZER screw compressor can be controlled for 4 Step capacity control, 3 Step capacity control or infinite capacity control where only (2) of the solenoids are used. The different means of capacity control can be achieved without any modification to the compressor required.

14.2 Scope of Standard Delivery

Scope of Standard Delivery (as supplied by Manufacturer)	Bitzer CSH	York DXS
Capacity control system : 4-Steps or Infinite Continuous (See Below)	No Modification Req	2 Step
25% to 100% Capacity Control	●	●
Conversion Kit Stepped to Stepless Control	Not Required	No
4 Step Capacity Control	●	No
Infinite Capacity Control	●	●
Solenoid coils for capacity control	●	Δ
Volume ratio Vi, Option Vi=2.2, 2.6, 3.0, 3.5	Built In	Built In
Discharge Check Valve	● Internal	● Internal
Suction Coupling tube and/or Flange	N/A	●
Discharge Coupling tube and/or Flange	N/A	●
Suction Service Valve	●	Δ
Discharge Service Valve	●	Δ
Suction service valve location	Top	End
Discharge service valve location	Top	End
Oil Charge	●	N/A
Electronic Module (Rotation)	●	External
Electronic Module (Temperature)	●	External
PTC100 type temperature sensor	N/A	N/A
PTC120 type temperature sensor	●	N/A
PT100 type motor temperature sensor	PTC Sensors	N/A
PTC110 type temperature sensor	N/A	N/A
Screw in Discharge temperature sensor	● (251F)	Thermistor
IP-54 Terminal box	●	
Crankcase oil heater	●	●
Compress chamber (Middle side) liquid inject port	●	N/A
Motor side (Low side) liquid inject port	Not Required	●
Economizer port	●	●
Oil cooling connection	●	N/A
Liquid injection oil cooling port	●	●
Oil drain valve	●	N/A
Oil level switch	Δ	N/A
Oil filter different pressure (ΔP) protector switch	Not Required	N/A
Liquid injection expansion valve	N/A	N/A
Liquid injection solenoid valve	N/A	N/A
Safety Valve	● Internal	N/A
Position sensor (Capacity control)	N/A	N/A
Slide fit motor	●	●
Starting type PWS	●	No
Starting type Start Delta	Δ	●
Jumper bars for DOL starting	●	
Rubber mounting pads	●	No
Oil Separator	Intregal	Δ Requires External
● (Standard) Δ (Option) N/A Not Applicable		

14 York YCAS and YCWS Series

14.3 Model Number Nomenclature

See section 1 for the BITZER CS series model number nomenclature.

NOMENCLATURE

The Model Number denotes the following characteristics of the unit:

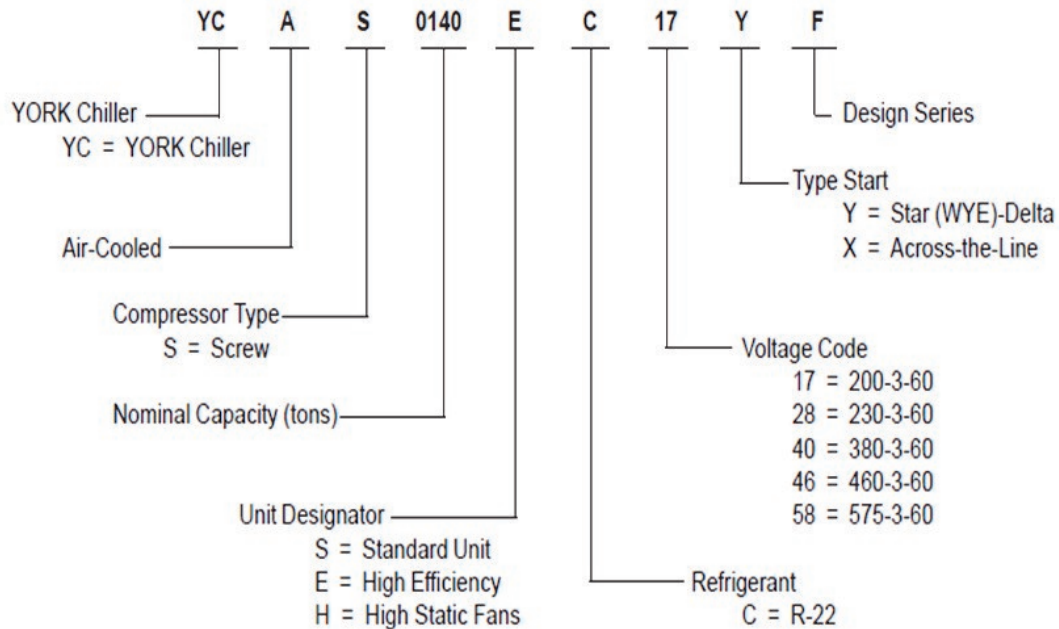

COMPRESSOR MODEL NOMENCLATURE

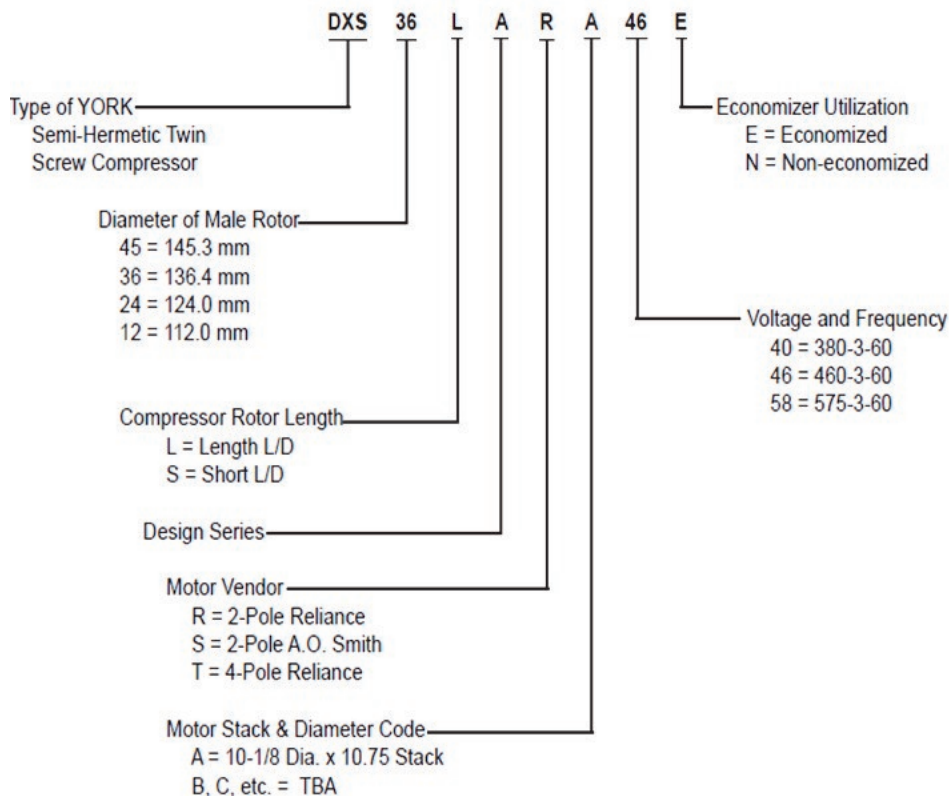

14.4 Millennium Style F Chillers 80-420 Tons

Chiller	Cir 1	Cir 2	Cir 3	Cir 4
0090EC	112	112	-	-
0100EC	112	112		
0110EC	124	112		
0120EC	124	112		
0130EC	124	124		
0140EC	124	124		
0150EC	136	124		
0160EC	136	136		
0170EC	136	136		
0180EC	136	136		
0200EC	145	145		
0210EC	145	145		
0230EC	145	145		
0250EC	136	136	136	
0270EC	136	136	145	
0300EC	145	145	145	
0330EC	145	145	145	
0360EC	145	145	136	136
0400EC	145	145	145	145
0440EC	145	145	145	145

MODEL NUMBER YCAS	0090EC	0100EC	0110EC	0120EC	0130EC	0140EC	0150EC	0160EC	0170EC	0180EC
Unit Capacity at ARI Conditions	82.9	88.9	102.8	108.5	121.1	130.1	145.3	157.1	164.3	171.6
Independent Ref Circuits	2	2	2	2	2	2	2	2	2	2
DXS Semihermetic Twin Screw										
Quantity per Chiller	2	2	2	2	2	2	2	2	2	2
Nominal Ton Size, Ckt.-1/Ckt.-2	42/42	46/46	62/45	68/45	62/62	68/68	78/68	78/78	85/78	85/85
Economizer, Ckt.-1/Ckt.-2	No/No	Yes/Yes	No/Yes	Yes/Yes	No/No	Yes/Yes	No/Yes	No/No	Yes/No	Yes/Yes
DXS Screw Model Ckt.-1/Ckt.-2	112/112	112/112	124/112	124/112	124/124	124/124	136/124	136/136	136/136	136/136

MODEL NUMBER YCAS	0200EC	0210EC	0230EC	0250EC	0270EC	0300EC	0330EC	0360EC	0400EC	0440EC
Unit Capacity at ARI Conditions	186.7	194.8	209.1	243.3	264.5	287.7	314.1	352.2	386.3	419.1
Independent Ref Circuits	2	2	2	3	3	3	3	4	4	4
DXS Semihermetic Twin Screw										
Quantity per Chiller	2	2	2	3	3	3	3	4	4	4
Nominal Ton Size, Ckt.-1/Ckt.-2	95/95	105/95	105/105	78/78	78/78	95/95	105/105	95/95	95/95	105/105
Nominal Ton Size, Ckt.-3/Ckt.-4	-/-	-/-	-/-	78/-	105/-	95/-	105/-	78/78	95/95	105/105
Economizer, Ckt.-1/Ckt.-2	No/No	Yes/No	Yes/Yes	No/No	No/No	No/No	Yes/Yes	No/No	No/No	Yes/Yes
Economizer, Ckt.-3/Ckt.-4	-/-	-/-	-/-	No/-	Yes/-	No/-	Yes/-	No/No	No/No	Yes/Yes
DXS Screw Model Ckt.-1/Ckt.-2	145/145	145/145	145/145	136/136	136/136	145/145	145/145	145/145	145/145	145/145
DXS Screw Model Ckt.-3/Ckt.-4	-/-	-/-	-/-	136/-	145/-	145/-	145/-	136/136	145/145	145/145

14 York YCAS and YCWS Series

14.5 Dimensions and Oil Data

York Dimensions			
Model	Length	Height	Width
DXS112			
DXS124			
DXS136			
DXS145			
Without Service Valves			

Bitzer CSH Dimensions			
Model	Length	Height	Width
CSH6563-50 / CSH6563-60	43"	19"	20"
CSH7553-70 / CSH7563-80	53"	23"	22"
CSH7573-90	53"	23"	22"
CSH7583-100 / CSH7593-110	54"	21"	22"
CSH8553-110 / CSH8563-125	60"	28"	27"
CSW6583-50 / CSW6593-60	47"	22"	22"
CSW7573-70 / CSW7583-80	53"	22"	22"
With Service Valves			

York Model	Oil Charge (Separators)	Oil Type R22
DXS112	2 gallons each	York "L" POE Oil
DXS124	2 gallons each	
DXS136	2 gallons each	
DXS145	2 gallons each	

Model	Suction	Discharge
DXS112	2-5/8"	1-3/8"
DXS124	2-5/8"	2-1/8"
DXS136	3-5/8"	2-5/8"
DXS145	3-5/8"	2-5/8"

Model	Suction	Discharge
CSH6553-50	2-1/8"	1-5/8"
CSH6563-60	2-1/8"	1-5/8"
CSH7553-70	3-1/8"	2-1/8"
CSH7563-80	3-1/8"	2-1/8"
CSH7573-90	3-1/8"	2-1/8"
CSH7583-100	3-1/8"	2-1/8"
CSH7593-110	3-1/8"	2-1/8"
CSW6583-50	2-5/8"	2-1/8"
CSW6593-60	2-5/8"	2-1/8"
CSW7573-70	3-1/8"	2-1/8"
CSW7583-80	3-1/8"	2-1/8"

14.6 Capacity Control

See section 5 for the capacity solenoid layout for the BITZER CS screw compressor.

Capacity Control Solenoid

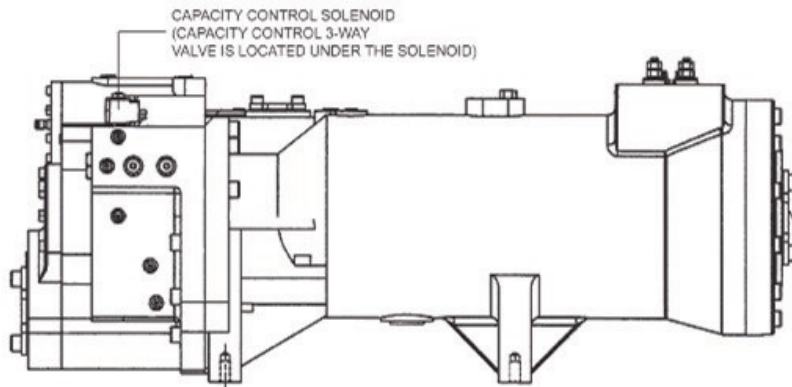

Below is a standard diagram of the wiring for the York DXS capacity control.

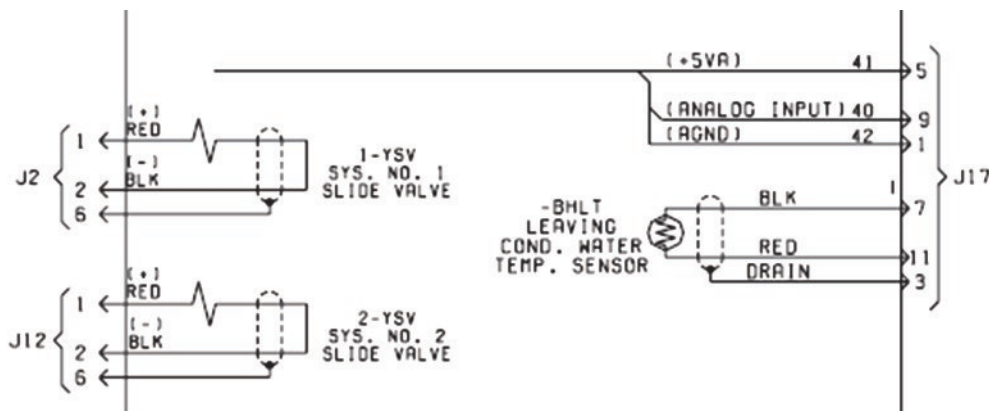

14 York YCAS and YCWS Series

14.7 Component Pictures and Layout

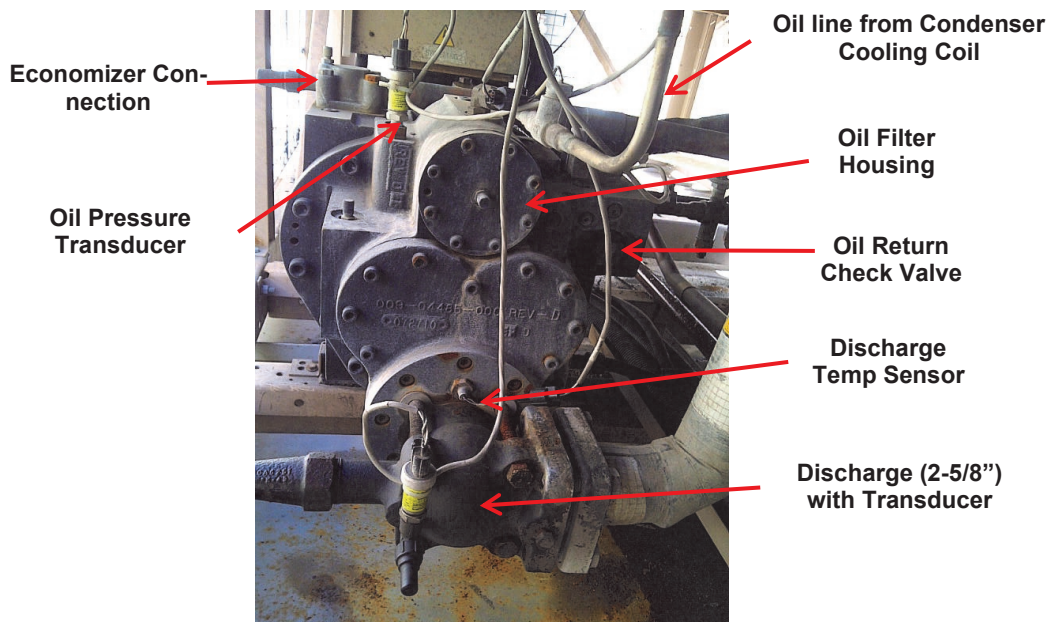
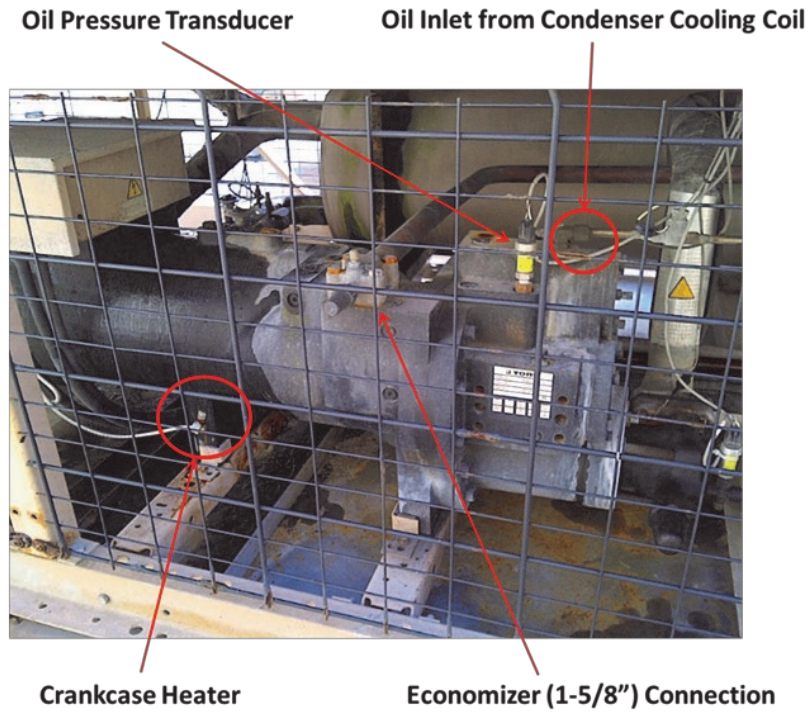

14.6 Component Pictures and Layout (Continued)

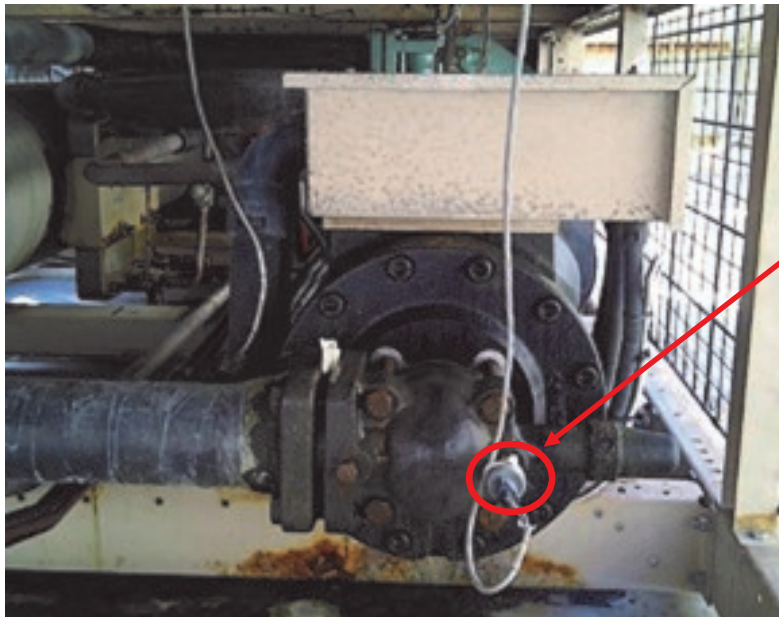

Suction Pressure
Sensor
and Transducer
Valve
Suct Vlv 3-5/8"

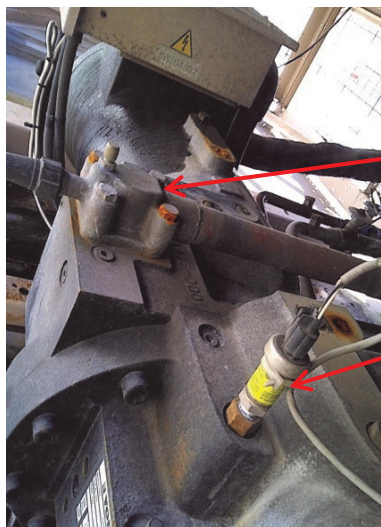

Economizer Connection
(if used)

Oil Pressure
Transducer

14.8 Preparing for Removal



Preparing for External Oil Separator Removal Including removal of the oil line piping and ball valves

Oil Separators Removed

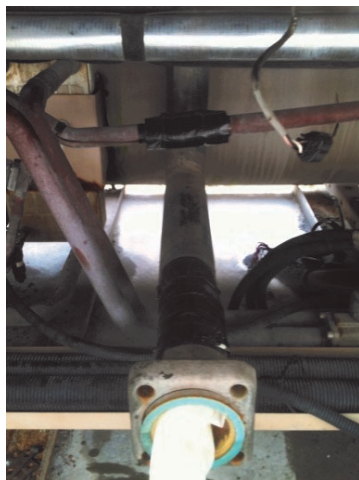

DXS45 compressors removed with existing suction and discharge piping shown

14.8 Preparing the Removal (Continued)



Economizer Heat Exchanger, Thermal Expansion and Solenoid Valve Removal



Base Frame cleaned and prepped for installation of BITZER CSH screws compressors

14 York YCAS and YCWS Series

14.9 Installing the BITZER CS Screw Compressor

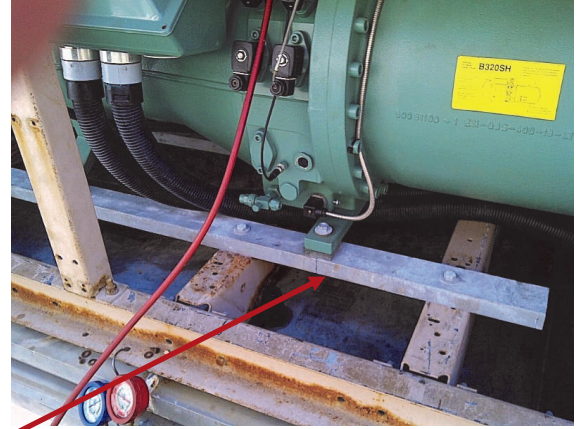

Added "U" Channel for Mounting of the CSH Bitzer Screw Compressor

Connector strip can be used to connect the crankcase heater as well as other connections.

SE-E1 Standard Electronic Module
(110/220 volt Standard)

Oil Temperature Sensor

T1 Motor Sensor
(brown wire)

L1
L2
L3

L7
L8
L9

T2 Motor Sensor
(brown wire)

Terminal Box Cover Ground Strap

CS85 Terminal box shown

14.9 Installing the BITZER CS Screw Compressor (Continued)

Oil pressure safety is monitored as the difference between suction and discharge pressures.

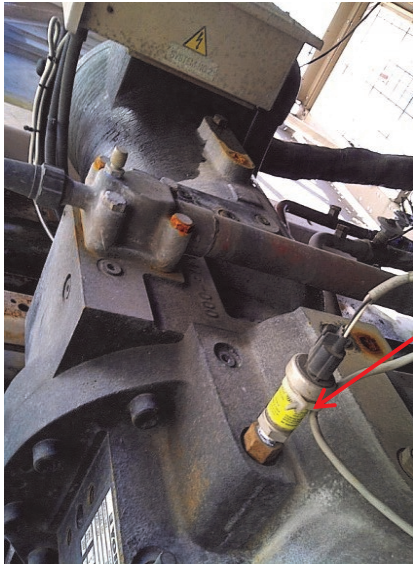

Oil Pressure Transducer



The existing oil pressure transducer was installed into the CS discharge pressure port. This transducer is connected to "J13" on the microprocessor board.

The existing discharge gas temperature sensor was attached to the BITZER discharge piping. The sensor is connected to "J8".



Discharge Temp Sensor

14 York YCAS and YCWS Series

14.9 Installing the BITZER CS Screw Compressor (Continued)

The existing suction and discharge pressure transducers were re-used on the BITZER compressor. These are connected to “J13 and J15”.

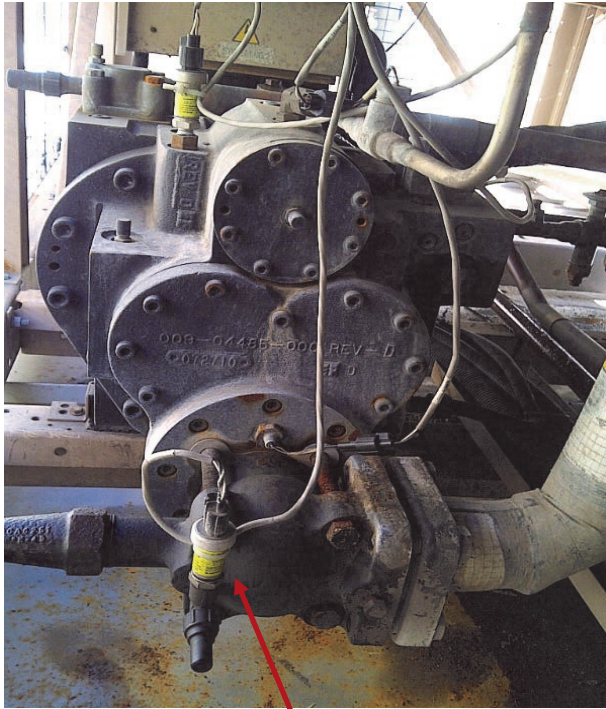

Discharge Pressure Transducer

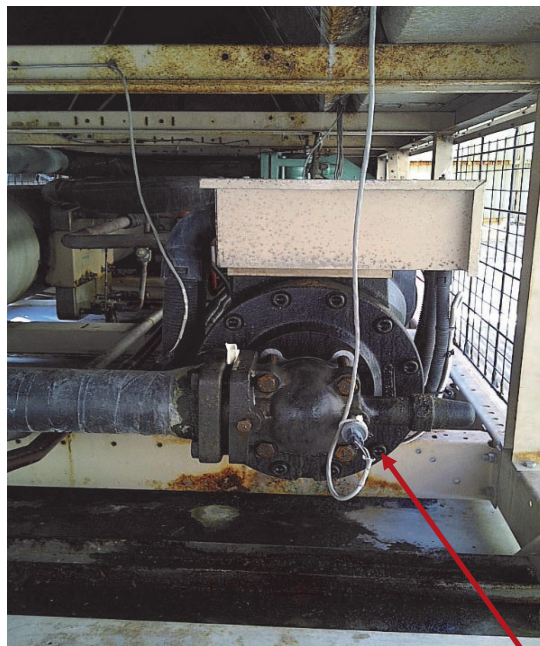

Suction Pressure Transducer

14.10 Modules and Electrical Info

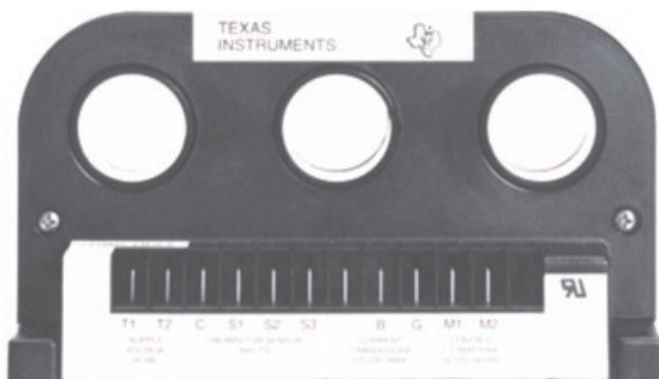
Typical York 2ACE Module

* T1 /T2 = Supply Voltage 24 VAC
* C / S1 / S2 / S3 = Thermistor Sensor Inputs
* B / G = Current Transducer 5.5 VDC Max
* M1 / M2 Control

Removing the 2ACE Module and Installing the BITZER SE-E1 Module:

The SE-E1 will be wired in series with the existing high pressure switch.

One side will be connected to “terminal 11” and the opposite side will be wired to “terminal 14” on the SE-E1.

A separate power supply from the control voltage (115 volt) was brought to “L and N” for module power.

The existing CT’s were reused and installed on “T1, T2 and T3”.

Note: the SE-E1 is prewired inside of the terminal box (motor winding PTC sensors and Oil Temp Sensor). T-1 and T-2 are the motor winding sensors. L1, L2 and L3 are the phase protection. The control circuit connections are “11 and 14”. Module power connections are “L and N”.

The existing York protection module was removed. “T1, T2, M1 and M2” were used to connect the BITZER SE-E1 electronic module.

The normal wiring to the York DXS crankcase heater were re-used to connect the BITZER 110 volt crankcase heater. The connection point was identified as #1 on the relay board.

14 York YCAS and YCWS Series

14.10 Models and Electrical Data (Continued)

The standard starting types used on the CS series (35 thru 140 horsepower) are PWS or DOL starting. The York DXS series standard delivery is Wye-Delta starting.

Typical Wye-Delta Start Set-up on a York DXS Compressor

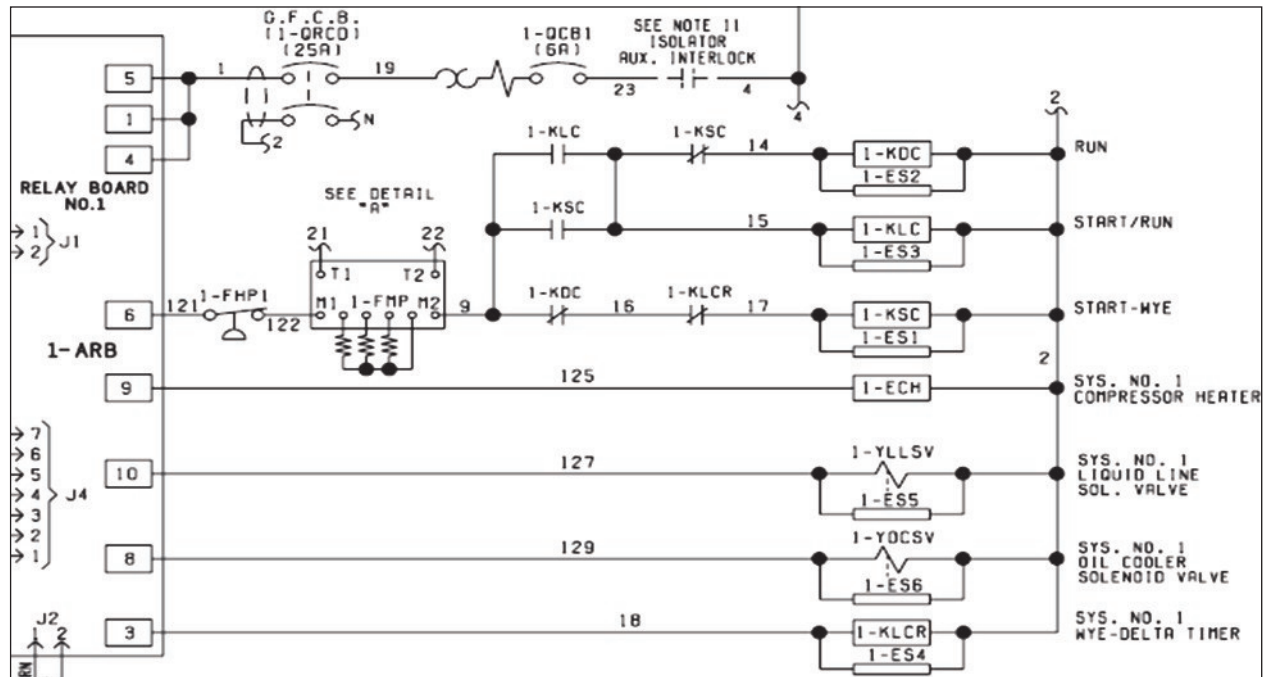

Typical Wye-Delta Start Set-up on a York DXS Compressor Shown with the Start Contactor Disconnect

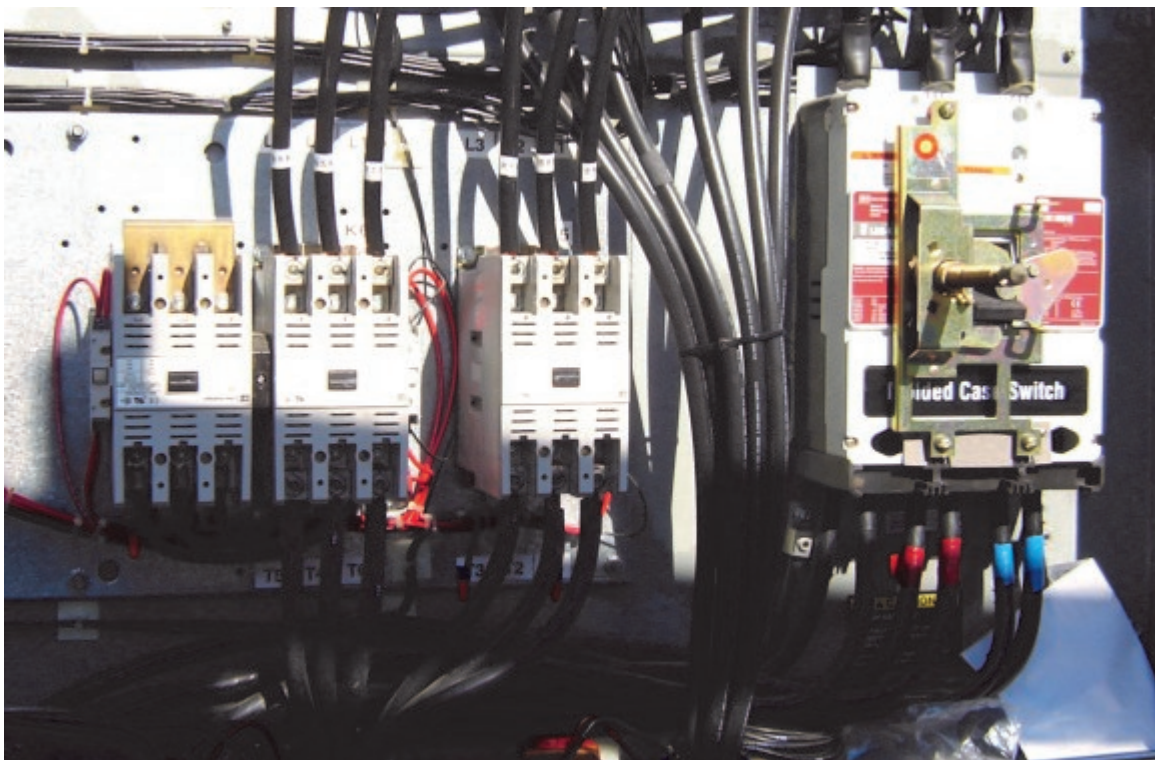

14.11 Piping

After the York compressor, oil separator and components have been removed and additional supports have been added to mount the BITZER compressor, piping modifications will have to be accomplished. There will actually be less piping resulting in lower possibility of refrigerant leakage once the BITZER is installed and piped in.

The suction piping needed (2) elbows to come up from the evaporator outlet piping that was already in place and a suction core filter drier was installed into the piping which required an additional elbow.

The discharge piping needed (2) elbows before it then led slightly down as it came towards the condenser inlet. (2) elbows were required to pipe into the condenser inlet which was originally the oil separator outlet which had been removed. This was accomplished so that any condensed refrigerant in the discharge line would be trapped rather than be allowed to migrate back to the compressor.

The following pictures show a replacement. Note, not all applications may require the same type of mounting and piping layout.

Added "U" Channel for Mounting of the CSH Bitzer Screw Compressor

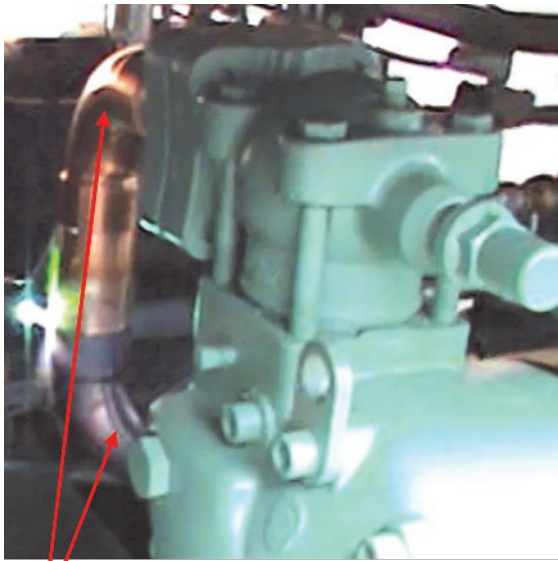

Suction connection shown with two new elbows. Discharge connection similar to suction.

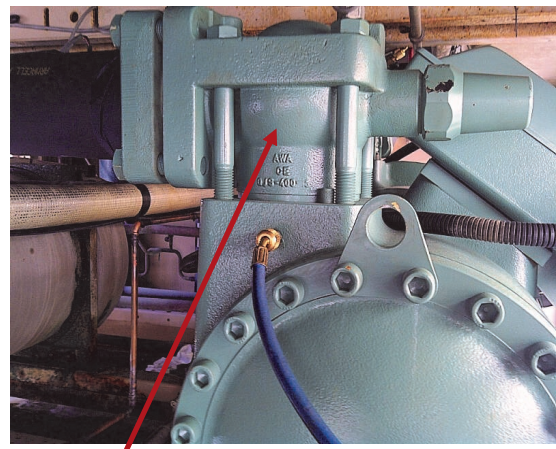

Suction Service Valve located on Top of Compressor

14 York YCAS and YCWS Series

14.11 Piping (Continued)

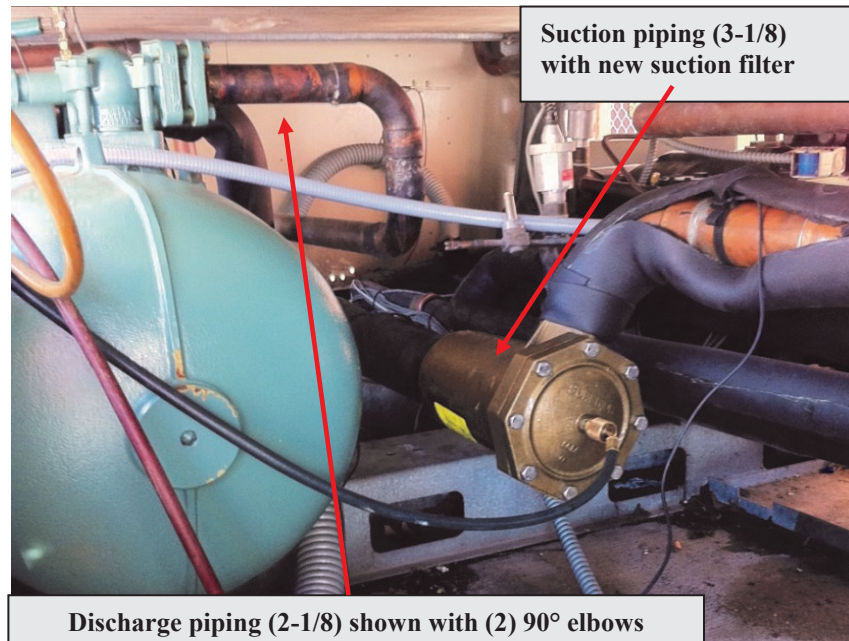

It is recommended to install a suction core filter drier or to re-use an existing drier when installing a BITZER CS compressor which aids in cleaning a circuit and also preventing system debris from entering the new compressor.

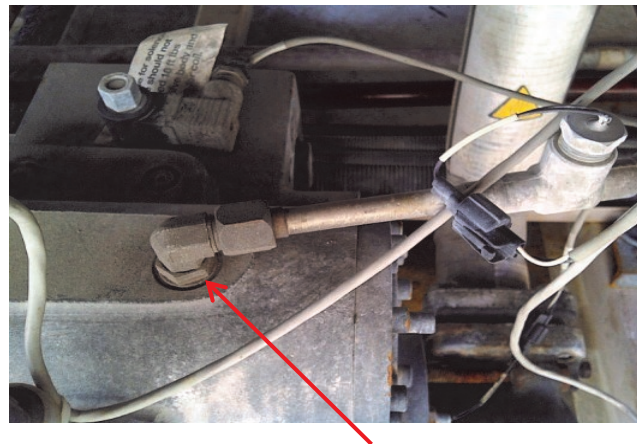

The York DXS compressors have oil cooling which is provided by routing oil from the oil separator through several of the top rows of the condenser coils back to the compressor.

14.12 Liquid Injection Oil Cooling (if required)

If oil cooling is required on the BITZER CS series screw compressors, most applications will apply liquid injection oil cooling. Consult BITZER Application Engineering guidelines to determine if any additional cooling will be required. Also, see section 7.

CSH Liquid Injection Controller Sensor Mounted on Discharge Piping

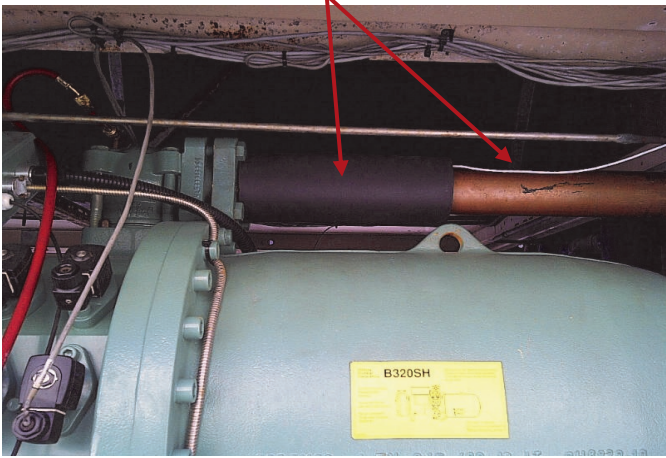

Existing Liquid Injection Supply Piping Re-used

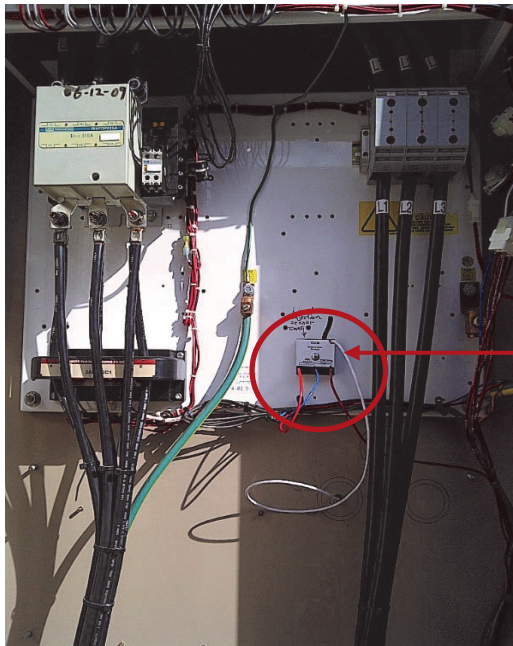
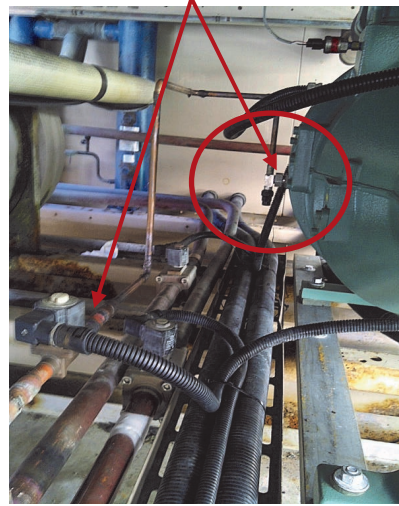

CSH Liquid Injection Controller Mounted in Control Panel

14 York YCAS and YCWS Series

14.13 York DXS Dimensions and Layout

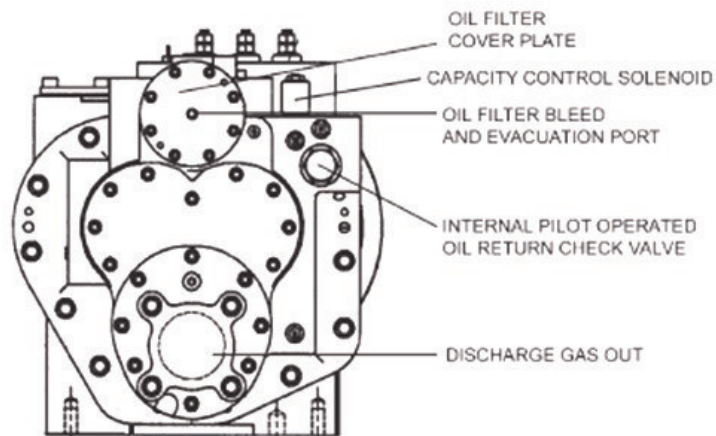
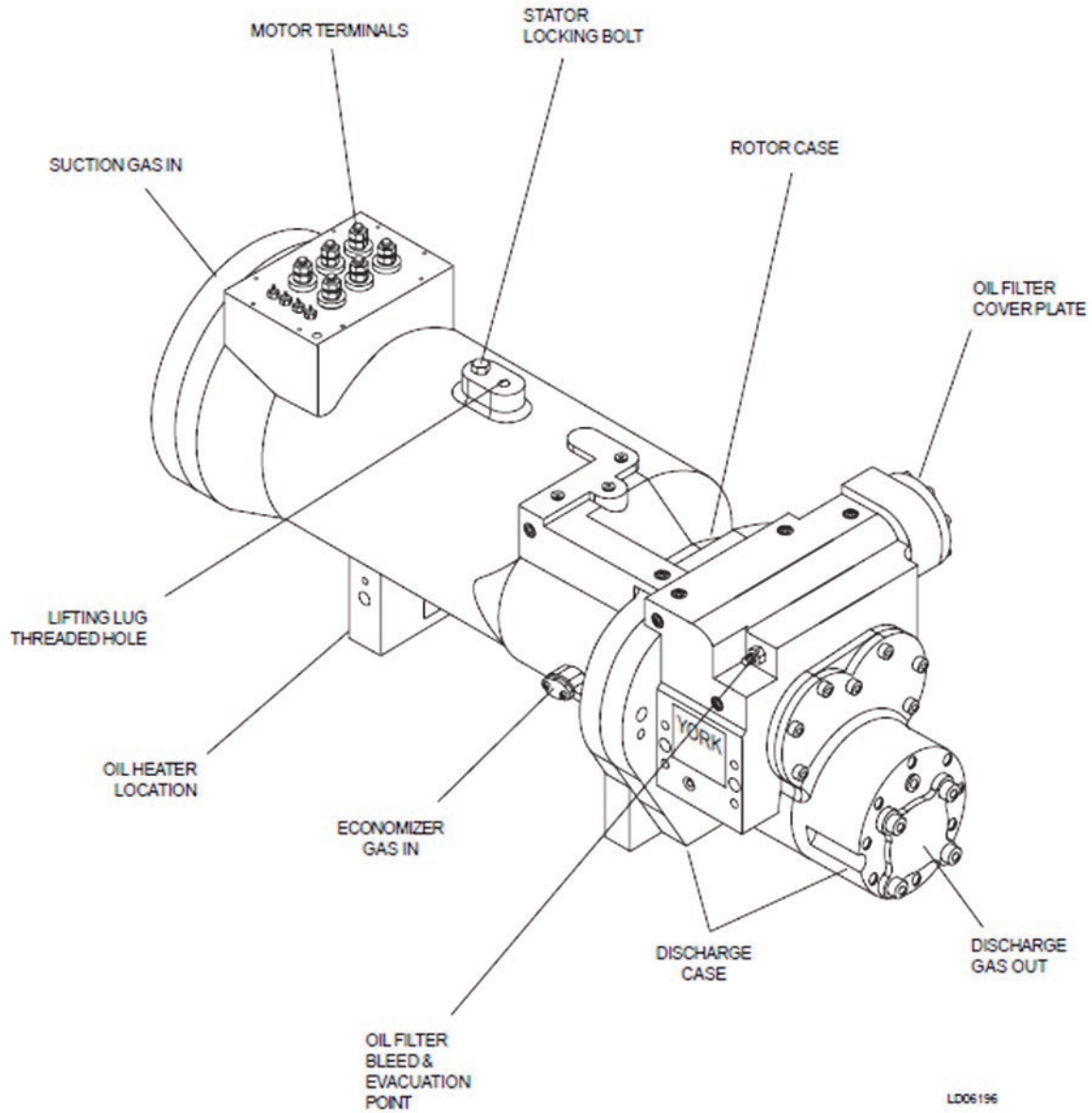

14.13 York DXS Dimensions and Layout (Continued)

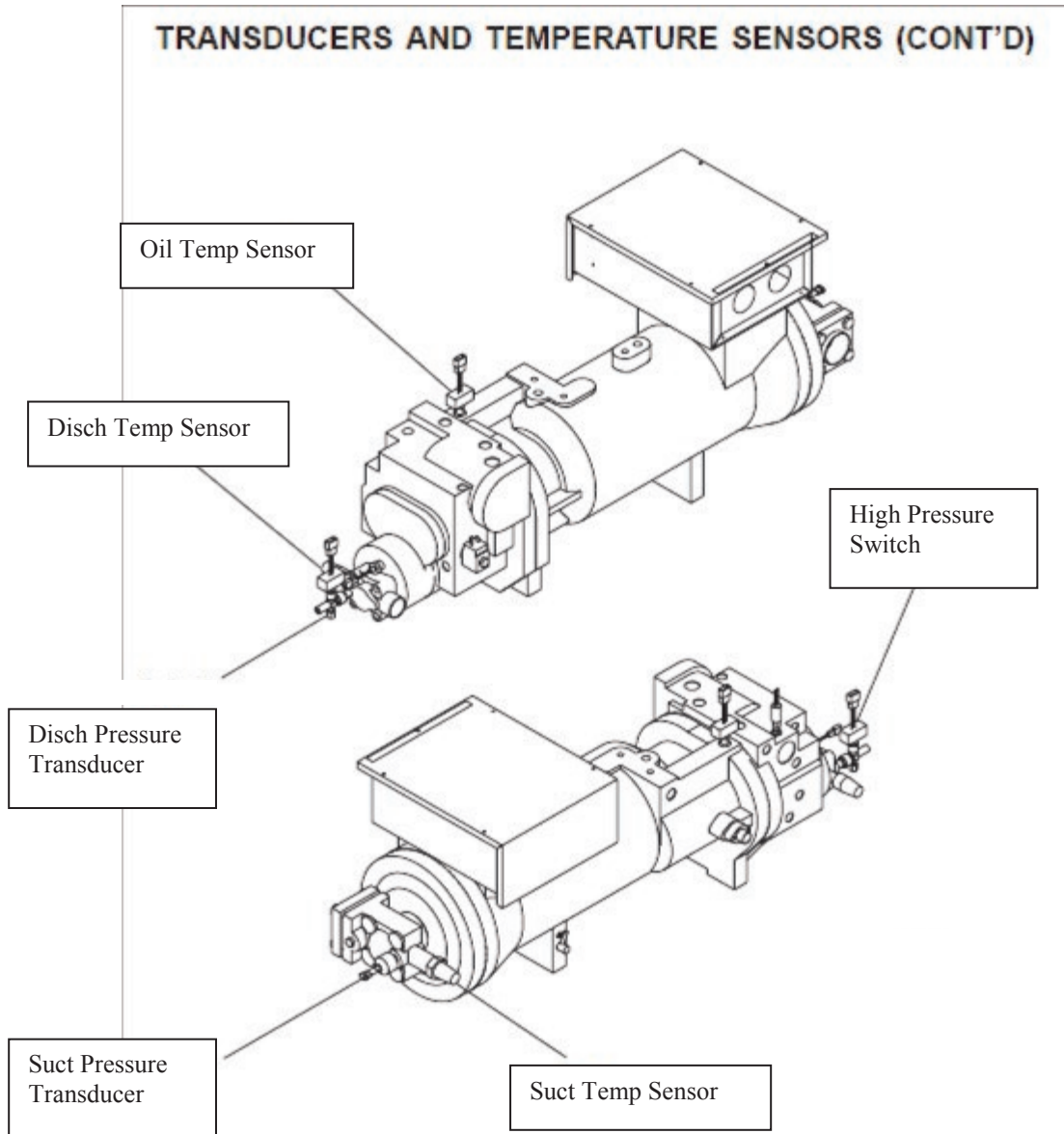

15 Carlyle 5H Reciprocating Series

15.1 Overview



Sizing Information:

For replacement compressor selection a capacity comparison of each compressor is given in section 3.

Mechanical Information:

The suction and discharge connection sizes are different between the Carlyle and the BITZER CS compressors.

The Carlyle 5H series compressors have the suction and discharge connection located on the tops of the compressors with the exception of the 5H40 and 5H46 series where the suction connection is located on the pump end of the compressor.

The 5H120 and 5H126 have require a discharge manifold to mount the service valve onto the compressor.

The 5H60 and 5H66 require a suction valve adapter to mount the service valve.

The BITZER CS compressors have the service valves located on the top of the compressor for the CS65, 75 and 85 series.

The suction connection is located on the ends for the CSW9563-140Y and CSW9573-160Y.

The suction and discharge isolation valves (if used) can be removed from the existing piping on the Carlyle compressor. The BITZER CS compressors are supplied with suction and discharge service valves.

All BITZER CS compressors are supplied with discharge check valves located under the discharge service valve. If external check valves are being utilized on the 5H compressors, these should be removed.

The weights of the compressors are also provided for comparison.

Wiring Information:

The control wiring for these compressors also has some differences.

The Carlyle 5H series do not have “on board” electronic modules. Any protection devices which are optional devices on these compressors should be considered to verify if they can be re-used on the BITZER CS compressors. Low pressure, high pressure cutouts can be re-used providing they are in good working condition and adjusted per actual operating parameters.

The Carlyle 5H compressors may utilize an Automatic Pumpdown Control or a Single Pumpout Control which is used to minimize liquid refrigerant remaining in the compressor’s crankcase during idle periods.

If the existing compressor is using an Automatic pumpdown control, this should not be used on the BITZER CS screw compressor.

If the existing compressor is using a Single Pumpout circuit, this can be re-used on the BITZER CS screw compressor providing the cut out set point is not in a vacuum and is configured for a “one time” pumpdown only.

All BITZER CS screw compressors are supplied with an electronic module pre-wired inside of the terminal box.

The BITZER electronic module provides oil temperature and motor winding temperature protection as well as phase rotation protection. The standard module is a dual voltage 110/220 volt power.

On the BITZER CS compressors the control circuit is wired through terminals 11 & 14 and module power is connected to L & N.

There is an additional connection on the BITZER CS protection module at terminal 12. This can be used to indicate a general compressor failure.

Operational Information:

The capacity control differs between the Carlyle reciprocating and BITZER screw compressors.

15.2 Scope of Standard Delivery

Scope of Standard Delivery (as supplied by Manufacturer)	Bitzer CSH	5H Series
Capacity control system : 4-Steps or Infinite Continuous (See Below)	No Modification Req	Option
25% to 100% Capacity Control	●	●
Conversion Kit Stepped to Stepless Control	Not Required	N/A
4 Step Capacity Control	●	No
Infinite Capacity Control	●	N/A
Solenoid coils for capacity control	●	N/A
Volume ratio Vi, Option Vi=2.2, 2.6, 3.0, 3.5	Built In	N/A
Discharge Check Valve	● Internal	● Internal
Discharge Check Valve 5H120 and 5H126	N/A	Δ Required
Suction-Discharge Manifold to mount service valves (5H60-66/5H120-126)	Not Required	Δ Required
Suction Service Valve	●	Δ
Discharge Service Valve	●	Δ
Suction service valve location (*except 5H40-46 on end)	Top	*Top
Discharge service valve location	Top	Top
Oil Charge	●	Δ (6/98)
Electronic Module (Rotation)	●	N/A
Electronic Module (Temperature)	●	N/A
PTC120 type temperature sensor	●	N/A
Screw in Discharge temperature sensor	● (251F)	N/A
IP-54 Terminal box	●	N/A
Crankcase oil heater	●	Δ
Liquid injection oil cooling port	●	N/A
Economizer port	●	N/A
Oil cooling connection	●	●
Oil drain valve	●	N/A
Oil level switch	Δ	N/A
Lubrication Oil Control	Not Required	Δ
Oil filter different pressure (ΔP) protector switch	Not Required	Δ External
Oil Filter Package	Not Required	Δ
Safety Relief Valve (except 5H120-126 external)	● Internal	● Internal
Slide fit motor	●	No
Starting type PWS	●	N/A
Starting type Start Delta	Δ	N/A
Jumper bars for DOL starting	●	N/A
Rubber mounting pads	●	No
Oil Separator	Intregal	Δ Requires External
● (Standard) Δ (Option) N/A Not Applicable		

15 Carlyle 5H Reciprocating Series

15.3 Model Number Nomenclature and Oil Charge

See section 1 for the BITZER CS series model number nomenclature.

5H120A219AA Nomenclature

5 = Open Drive Compressor

H = 3-1/4" Diameter Bore

12 = 12

Cylinder

8 = 8 Cylinder

6 = 6 Cylinder

4 = 4 Cylinder

0 = Original Design 2-3/4" Stroke

A = Service (reman) Cast Iron

B = Private Brand

C = Standard

Model

S = Service (New)

219 = Three Digits Sequential as Assigned

A = Service Models Only

A = Service Models Only

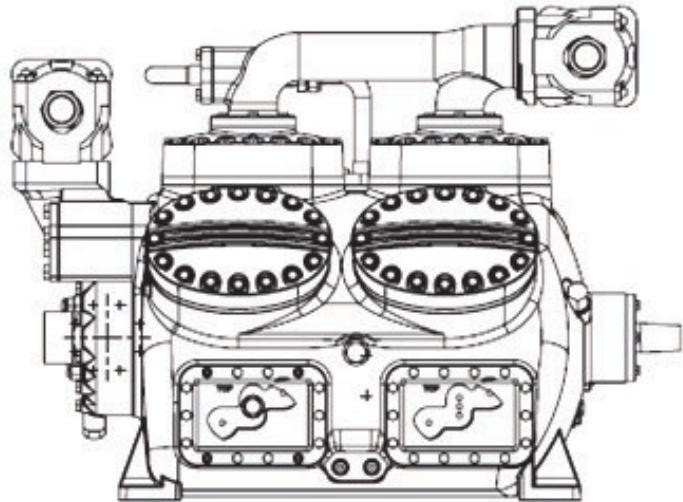

Oil Charge:

5H	Oil Charge
5H40	2.3
5H46	2.3
5H60	2.6
5H66	2.6
5H80	5.13
5H86	5.13
5H120	7.63
5H126	7.63
(gallons)	

CSH	Oil Charge
6553-50	2.6
6563-60	2.6
7553-70	4.1
7563-80	4.1
7573-90	4.1
7583-100	4.1
7593-110	4.1
8553-110	6.0
8563-125	6.0
8573-140	6.0
(gallons)	

CSW	Oil Charge
6583-50	2.8
6593-60	2.8
7573-70	4.1
7583-80	4.1
7593-90	4.1
8573-110	6.0
(gallons)	

15 Carlyle 5H Reciprocating Series

15.4 Capacity Control

Please see section 5 for more BITZER solenoid valve information

The Carlyle 5H series offers a pressure type cylinder unloading. The cylinder unloading mechanism is powered by a compressor force feed lubricating system.

The set point is controlled via an external adjusting stem which is set to the desired suction pressure.

There are 3 major components associated with the capacity control; Capacity control valve, Power elements and Valve lifting mechanism.

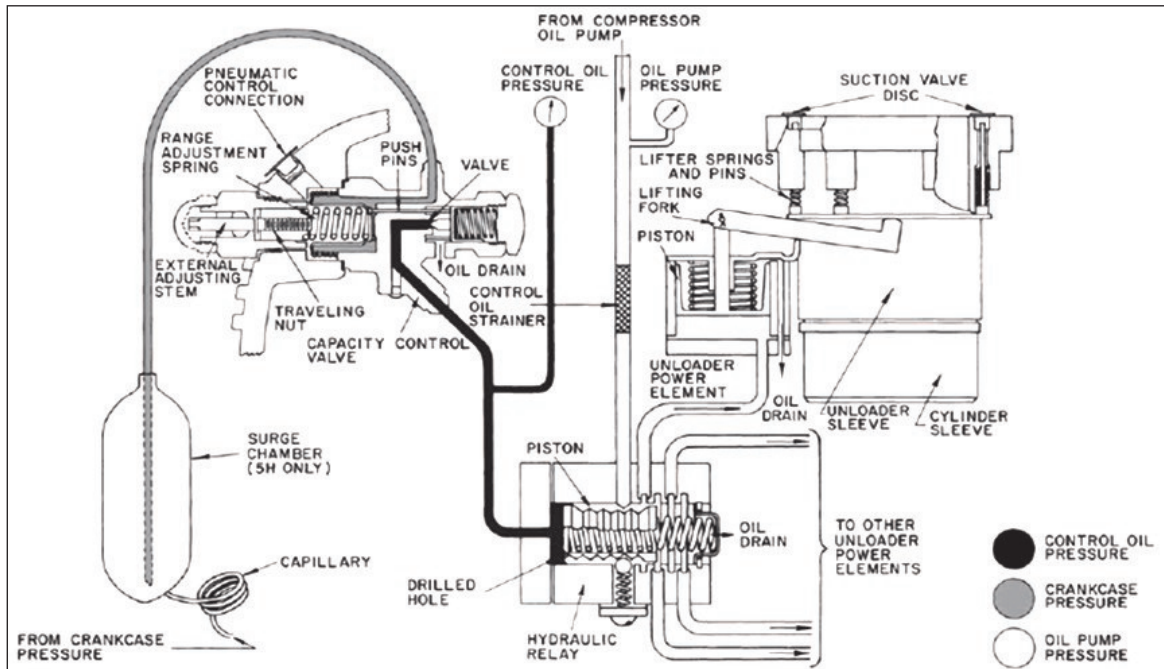

Fig. 7 — Capacity Control — 5F40, 60; 5H40, 46, 60, 66, 80 and 86

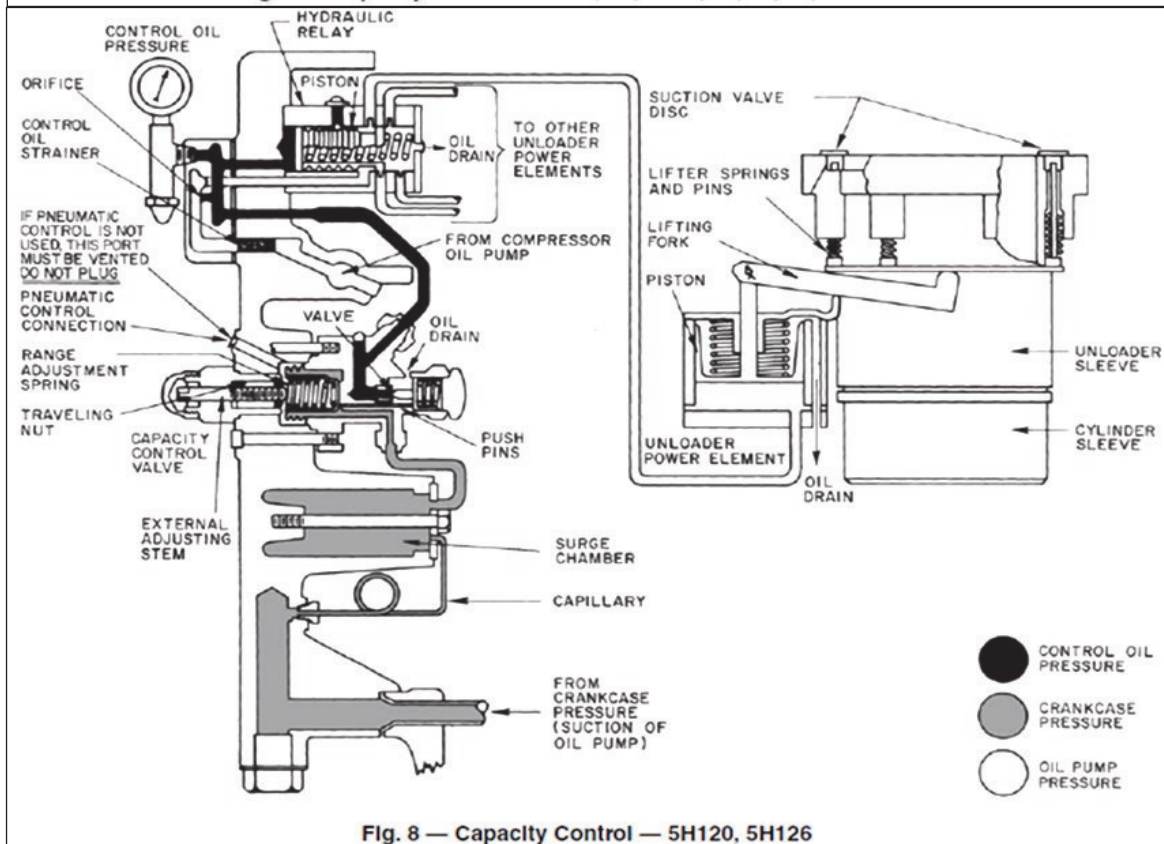

Fig. 8 — Capacity Control — 5H120, 5H126

15.5 Dimensions and Weight Comparison

5H Dimensions (inches)			
5H Model	Length	Height	Width
5H40	31	29	25
5H46	31	29	25
5H60	32	30	27
5H66	32	30	27
5H80	44	32	25
5H86	44	32	25
5H120	47	35	27
5H126	47	35	27
Bare Compressor Only			

Bitzer CSH Dimensions			
Model	Length	Height	Width
6553-50	44	22	20
6563-60	44	22	20
7553-70	53	22	22
7563-80	53	22	22
7573-90	53	22	22
7583-100	54	22	22
7593-110	54	22	22
8553-110	61	28	27
8563-125	61	28	27
8573-140	61	28	27
With Service Valves			

Bitzer CSW Dimensions			
Model	Length	Height	Width
6583-50	44	22	20
6593-60	44	22	20
7573-70	53	23	22
7583-80	53	23	22
7593-90	53	23	22
8573-110	61	28	27
8583-125	61	28	27
8593-140	61	28	27
With Service Valves			

Carlyle Model	Weight
5H40	610
5H46	610
5H60	795
5H66	795
5H80	1115
5H86	1115
5H120	1580
5H126	1580
Bare Compressor	

Bitzer CSH Model	Bitzer Weight
6553-50	717
6563-60	717
7553-70	1147
7563-80	1158
7573-90	1180
7583-100	1191
7593-110	1224
8553-110	1874
8563-125	1896
8573-140	1918

Bitzer CSW Model	Bitzer Weight
6583-50	805
6593-60	805
7573-70	1147
7583-80	1169
7593-90	1180
8573-110	1874

15 Carlyle 5H Reciprocating Series

15.6 Connection Size Comparison and Oil Types

5H Model	Suction Valve	Discharge Valve
5H40	2-5/8"	2-1/8"
5H46	2-5/8"	2-1/8"
5H60	3-1/8"	3-1/8"
5H66	3-1/8"	3-1/8"
5H80	3-1/8"	3-1/8"
5H86	3-1/8"	3-1/8"
5H120	4-1/8"	4-1/8"
5H126	4-1/8"	4-1/8"

CSH Model	Suction Valve	Discharge Valve
6553-50	2-1/8"	1-5/8"
6563-60	2-1/8"	1-5/8"
7553-70	3-1/8"	2-1/8"
7563-80	3-1/8"	2-1/8"
7573-90	3-1/8"	2-1/8"
7583-100	3-1/8"	2-1/8"
7593-110	3-1/8"	2-1/8"
8553-110	4-1/8"	3-1/8"
8563-125	4-1/8"	3-1/8"
8573-140	4-1/8"	3-1/8"

CSW Model	Suction Valve	Discharge Valve
6583-50	2-5/8"	2-1/8"
6593-60	2-5/8"	2-1/8"
7573-70	3-1/8"	2-1/8"
7583-80	3-1/8"	2-1/8"
7593-90	3-1/8"	2-1/8"
8573-110	4-1/8"	3-1/8"

Compressor Oil Types

Carlyle 5H Oil Types
Cryol 150
Cryol 150 with oil additives
Suniso 3GS
Suniso 4GS
Texaco WF32-150
Zerol 150

B320SH Polyolester Oil (R22)	
Unit of Measurement	Part #
1 gallon	793-3320-01
5 gallon	793-3320-34

BSE170 Polyolester Oil (HFC)	
Unit of Measurement	Part #
1 gallon	793-1170-34
5 gallon	793-3170-34

BSE170L Polyolester Oil (CSW R134A)	
Unit of Measurement	Part #
1 liter	915118-06
5 liter	915118-01
10 liter	915118-02

15.7 5H Series Outline Drawings

Carlyle 5H 40/46 Assemblies Drawing

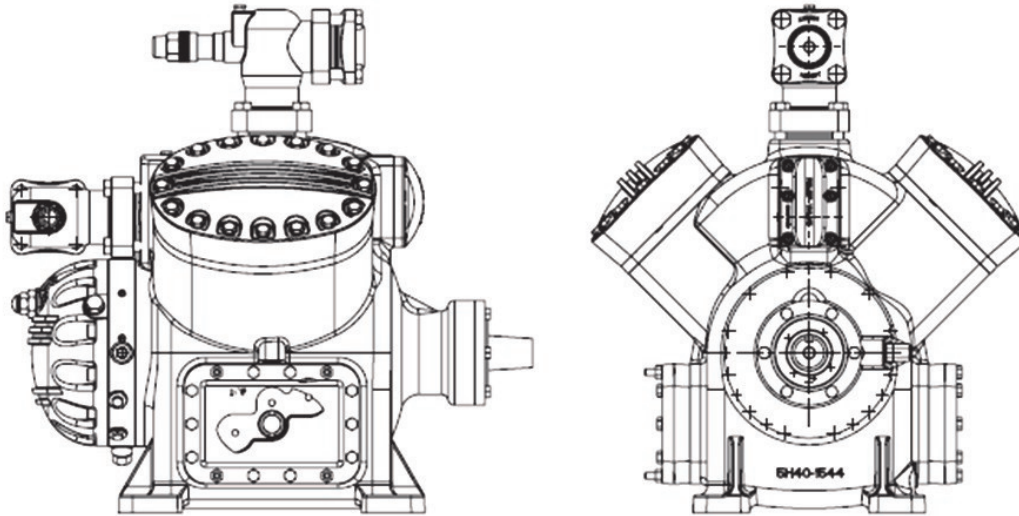

Carlyle 5H 60/66 Assemblies Drawing

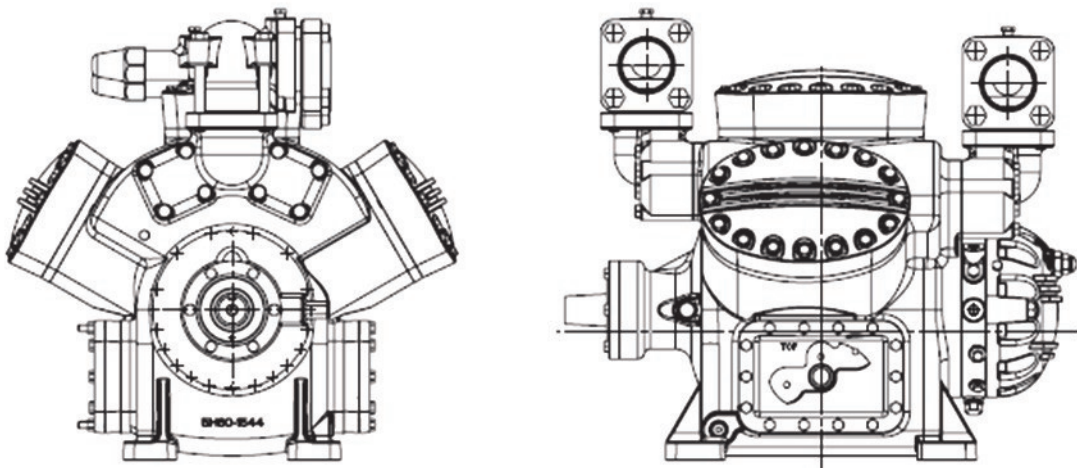

15 Carlyle 5H Reciprocating Series

15.7 5H Series Outline Drawings (Continued)

Carlyle 5H 80/86 Assemblies Drawing

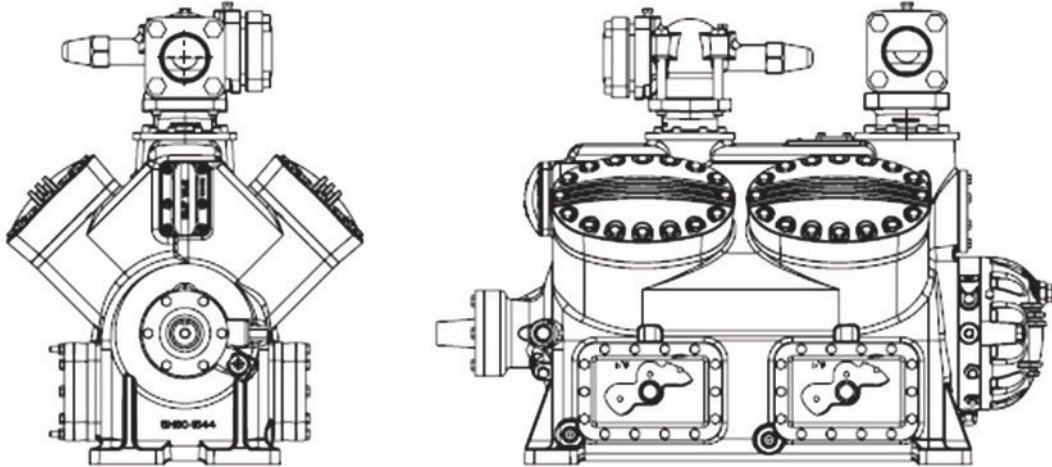

Carlyle 5H 120/126 Assemblies Drawing

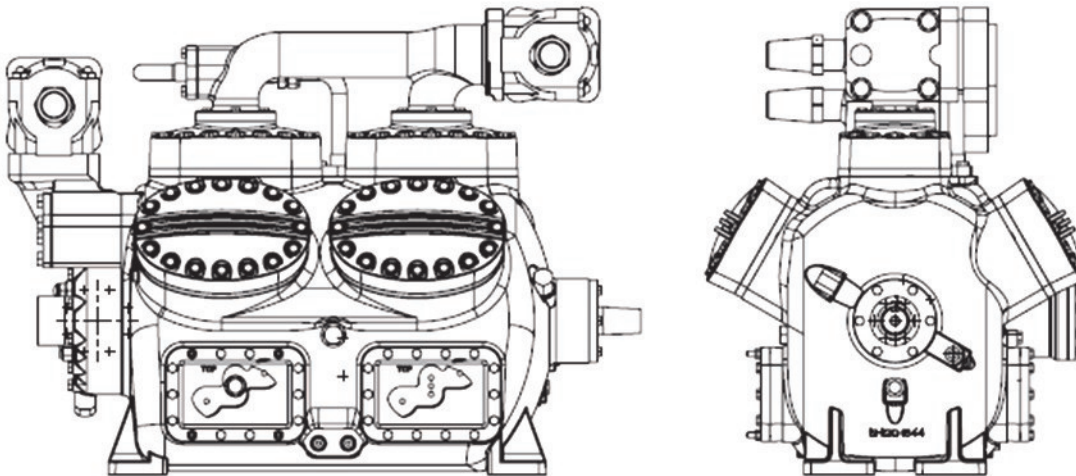

15.8 5H Series to BITZER CS Series Conversion Pictures

Carlyle 5H86 100HP to BITZER CSW7583-80-4PU

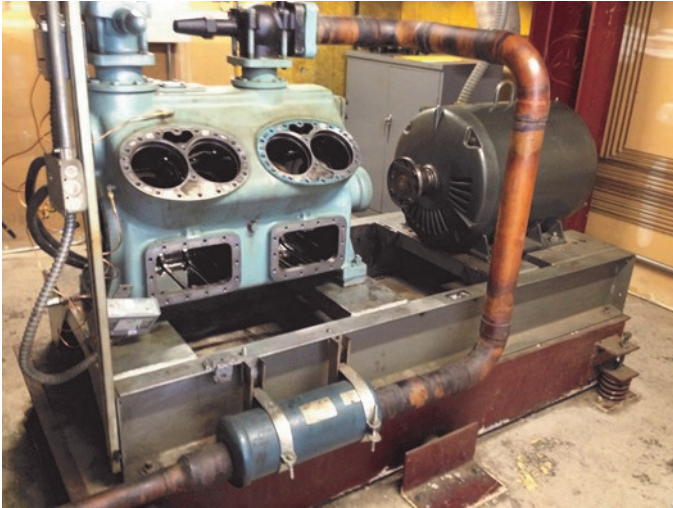

Carlyle 5H60 to BITZER CSW6593-60-4PU



Carlyle 5H66 to BITZER CSW6593-60-4PU

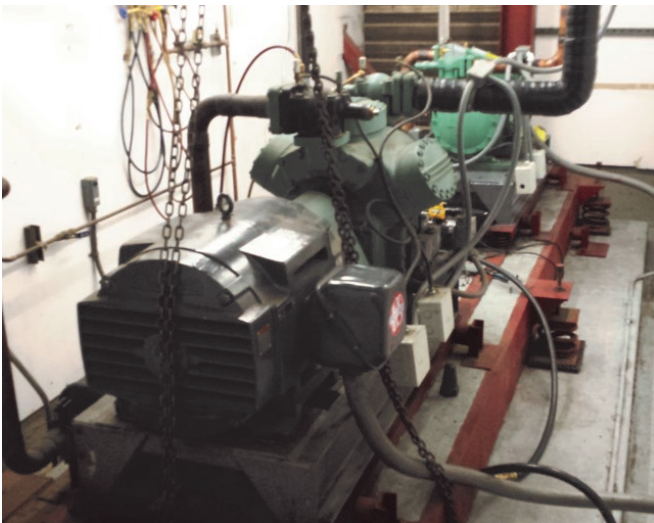

16 Technical Documentation

16.1 Official BITZER Literature

www.bitzerus.com

Spare Parts

SE-161	CS65 SERIES
SE-171	CS75 SERIES
SE-181	CS85 SERIES
SE-191	CS95 SERIES

Performance Data

SP-173	CSW SCREW COMPRESSORS (IP UNITS @ 60Hz)
SP-176	CSH SCREW COMPRESSORS (IP UNITS @ 60Hz)

Operating Instructions

SB-170	CS SCREW COMPRESSORS
--------	----------------------

Application Manual

SH-170	CS3 SCREW COMPRESSORS
--------	-----------------------

Technical Information

ST-120	SE-E1 PROTECTION DEVICES
ST-121	SE-C1 &SE-C2 PROTECTION DEVICES
ST-122	SE-E2 PROTECTION DEVICES
ST-130	OLC-D1-S OIL LEVEL MONITORING
ST-410	MOTOR CODES
ST-500	OIL PROPERTIES
ST-600	PIPING ARRANGEMENT
ST-610	ECONOMIZER OPERATION
ST-620	PARALLEL OPERATION

Maintenance Information

SW-100	TORQUE SPECIFICATION
SW-120	CHECKING AND ADJUSTING AXIAL CLEARANCE
SW-170	INSPECTION AND REPLACEMENT INTERVALS

16.2 Official BITZER US Literature

Available on request

Technical Bulletins

TB-0008	CONTROL MODULES AND APPLICATION KIT FOR SCREWS
TB-0012	CAPACITY CONTROLLER FOR CSH
TB-0014	COMPACT SCREW OILS
TB-0016	LIQUID INJECTION FOR CSH SCREWS
TB-0017	OIL DRAINING FOR CSH SCREWS
TB-0018	HSKC TO CSH CONVERSION GUIDELINES
TB-0020	CS SCREW COMPRESSOR BOLT TORQUE SPECIFICATIONS
TB-0021	INT69 TO SE-E1 FIELD REPLACEMENT INSTRUCTIONS
TB-0022	SE-E1 TROUBLESHOOTING GUIDELINES
TB-0023	OLC-D1-S OPTICAL OIL SENSOR FOR CS SCREWS
TB-0029	SE-E2 MOTOR PROTECTION MODULE
TB-0030	BITZER GUIDELINES FOR CS FIELD MOTOR REPLACEMENT
TB-0035	REPLACING THE DISCHARGE CHECK VALVE FOR CSH
TB-0038	CSH1 TO CSH3 CONVERSION GUIDELINES
TB-0039	ADDITIONAL SLIDE VALVE CAPACITY CONTROLLERS
TB-0041	SYSTEM CONTROL MODULE

Reference Charts

CRC-0012	COMPRESSOR OIL CAPACITIES
CRC-0048	OIL TYPES
CRC-0050	SCREW INFORMATION
CRC-0051	CONTACTORS

Service Guides

SG-0004	CS TROUBLESHOOTING GUIDE
SG-0005	CS SERVICE GUIDE

Customer Forms

CF-0001	RETURN MATERIAL AUTHORIZATION (RMA) FORM
CF-0017	SCREW COMPRESSOR SYSTEM INFORMATION REQUEST

BITZER US, Inc.

4080 Enterprise Way
Flowery Branch, GA 30542
Phone: 770-718-2900
Fax: 770-503-9440
Email: sales@bitzerus.com

24h Emergency Replacement Hotline for US Customers:

1.888.GO BITZER (1.888.462.4893)

BITZER Canada, Inc.

21125 Daoust Street
Sainte-Anne-De-Bellevue, QC, H9X 0A3, Canada
Phone: 514-697-3363
Fax: 514-697-9768
www.bitzer.ca

BITZER Mexico S. de R.L. de C.V.

Av. Adolfo López Mateos 221, Bodega 9, Col. Victoria
67110 Guadalupe, N.L., Mexico
Phone: +52 (81) 1522 4500
Fax: +52 (81) 1522 4505
www.bitzermexico.com

BITZER Latin America

Phone +1 770 718 2914
ecuador@bitzerus.com
colombia@bitzerus.com
venezuela@bitzerus.com
puertorico@bitzerus.com
caribe@bitzerus.com
centroamerica@bitzerus.com