Hartford Dunham Bush NHF Series to BITZER CSH

Competitive
Replacement
Guideline

XR-0019-01 01/13



BITZER Screw Compressors CS High Temp Series

The intention of this document is to serve as general guidelines. The information contained is not intended to replace specific equipment and/or system manufacturer's information or guidelines. BITZER implies no liability for the information contained. It is BITZER's implicit intention that nothing contained in this guide replaces any past, present or future warranty policy of BITZER and/or any other manufacturer's equipment

These guidelines are supplied as a recommended procedure for troubleshooting the CS screw compressor

These guidelines are not a replacement for information specific to that of the manufacturer or the manufacturer's system technical product information.

Each system may vary in design, usage and specifications. This document is intended for use specific to the compressor only and not intended to be a "catch all" for any and every possible application of the compressor.

BITZER's intention is that only qualified and certified (where applicable) individuals specific to the refrigeration industry use the information contained and all standard refrigeration handling and safety practices must be followed at all times.

BITZER's intention is that all electric work is performed by qualified and certified (where applicable) individuals and all standard electrical safety practices must be followed at all times.



WARNING

This icon indicates instructions to avoid personal injury and material damage



CAUTION

This icon indicates instructions to avoid property damage and possible personal injury



HIGH VOLTAGE

This icon indicates operations with a danger of electric shock

Table of Contents

Scope of Delivery BITZER CS and Hartford NHF Series	2
Capacity Comparison	3,4
CFH Ratings	4
Model Number Nomenclature MSC110 and MSC127	5
Model Number Nomenclature BITZER CSH and CSW	6
Overview	7
Capacity Control	8,9
Module Types	10 – 14
Oil Types	14
MSC 110 Dimensions	15
MSC 127 Dimensions	16
Replacement Pictures	17,18
Connection Sizes	19
CSH / CSW Accessories	20
CSH / CSW Oil Part Numbers	21
CSH Drawings	22,23
Competitive Replacement Request Form	24

Scope of Standard Delivery (as supplied by Manufacturer)	Bitzer CSH	Hartford NHF (MSC)
Capacity control system : 4-Steps or Infinite Continuous (See Below)	No Modification Req	2 Step
25% to 100% Capacity Control	●	●
Conversion Kit Stepped to Stepless Control	Not Required	No
4 Step Capacity Control	●	No
Infinite Capacity Control	●	●
Solenoid coils for capacity control	●	Δ
Volume ratio Vi, Option Vi=2.2, 2.6, 3.0, 3.5	Built In	Δ
Discharge Check Valve	● Internal	Suction
Suction Coupling tube and/or Flange	N/A	Δ
Discharge Coupling tube and/or Flange	N/A	Δ
Suction Service Valve	●	Δ
Discharge Service Valve	●	Δ
Suction service valve location	Top	Side
Discharge service valve location	Top	Top or Side
Oil Charge	●	●
Electronic Module (Rotation)	●	Δ
Electronic Module (Temperature)	●	Δ
PTC100 type temperature sensor	N/A	N/A
PTC120 type temperature sensor	●	N/A
PT100 type motor temperature sensor	PTC Sensors	N/A
PTC110 type temperature sensor	N/A	N/A
Screw in Discharge temperature sensor	● (251F)	● (240F)
IP-54 Terminal box	●	
Crankcase oil heater	●	●
Compress chamber (Middle side) liquid inject port	●	
Motor side (Low side) liquid inject port	Not Required	
Economizer port	●	●
Oil cooling connection	●	●
Liquid injection oil cooling port	●	●
Oil drain valve	●	●
Oil level switch	Δ	●
Oil filter different pressure (ΔP) protector switch	Not Required	Not Required
Liquid injection expansion valve	N/A	Δ
Liquid injection solenoid valve	N/A	Δ
Safety Valve	● Internal	Δ
Position sensor (Capacity control)	N/A	N/A
Slide fit motor	●	No
Starting type PWS	●	●
Starting type Start Delta	Δ	Δ
Jumper bars for DOL starting	●	Δ
Rubber mounting pads	●	Δ
Oil Separator	Intregal	Intregal
● (Standard) Δ (Option) N/A Not Applicable		

Hartford Dunham Bush

R22							
BITZER Model	HP	Capacity kBtu	Capacity Tons	Hartford / Dunham Bush Model	HP	Capacity kBtu	Capacity Tons
CSH6553-50	50	429	36	1010NHF6V4*	35	442	37
CSH6553-50	50	429	36	1010NHF6V5*	50	442	37
CSH6563-60	60	538	45	1012NHF6V4*	50	557	46
CSH6563-60	60	538	45	1012NHF6V6*	80	557	46
CSH7553-70	70	632	53	1015NHF6V4*	60	670	56
CSH7553-70	70	632	53	1015NHF6V5*	80	670	56
CSH6563-60	60	538	45	1111NHF6_4	65	536	45
CSH6563-60	60	538	45	1111NHF6_6	75	536	45
CSW6583-50	50	657	55	1113NHF6_4	75	666	56
CSW6583-50	50	657	55	1113NHF6_6	95	666	56
CSH7563-80	80	735	61	1117NHF6_4	85	778	65
CSH7563-80	80	735	61	1117NHF6_6	115	778	65
CSH7573-90	90	885	74	1210NHF6W3	60	859	72
CSH7573-90	90	885	74	1210NHF6W4	80	859	72
CSH7573-90	90	885	74	1210NHF6X6	120	859	72
CSW7593-90	90	1171	97	1212NHF6W3	80	1091	91
CSW7593-90	90	1171	97	1212NHF6W4	100	1091	91
CSW7593-90	90	1171	97	1212NHF6X6	150	1091	91
CSH8573-140	140	1425	118	1215NHF6V4	120	1344	112
CSH8573-140	140	1425	118	1215NHF6X6	150	1344	112
CSH8573-140	140	1425	118	1215NHF6X6K	175	1344	112
CSW8583-125	125	1600	133	1218NHF6X6	200	1602	133
Operating Condition 30/105/10/10							

BITZER CSH Model Data				
Model Number	Rated Nominal Tonnage	CFM DISPL 60Hz	CFH DISPL 60Hz	Motor HP
CSH6553-50	42	97	5830	50
CSH6563-60	53	121	7244	60
CSH7553-70	59	140	8410	70
CSH7563-80	68	161	9682	80
CSH7573-90	83	183	10989	90
CSH8553-110	96	224	13428	110
CSH8563-125	112	255	15300	125
CSH8573-140	134	292	17491	140
CSH9553-180	180	380	22802	180
Rated Nominal Tonnage 45/130/20/15 R22 +/-5%				

D/B Hartford Model Data				
Model Number	Rated Nominal Tonnage	CFM DISPL 60Hz	CFH DISPL 60Hz	Motor HP
1111	52	118	7080	75
1113	67	146	8760	95
1117	80	176	10560	115
1210	83	186	11160	120
1212	106	232	13920	150
1215	131	279	16740	175
1218	156	335	20100	200
Rated Nominal Tonnage 45/130/20/15 R22 +/-5%				

MSC127 Series



MSC110 Series



DB Model Number Nomenclature

MODEL (Example): 1215NHF6W4K0EMBJOC

12	15	N	H	F
Rotor Diameter	Rotor L/D Ratio	Compressor Type	Temp App	Refrigerant
12 = 127mm 11 = 110mm	10 = 1.00 12 = 1.25 15 = 1.50 18 = 1.80	B = Flanged Semi N = Fully Hermetic	H = High L = Commercial U = Low	F = R22,404A,407C,507 L = R134A
6	W	4	K	OEM
Unloading	Injection Type	Motor Sizing	Version	Assembly Level
6 = Auto Start	V = Vapor & Liquid W = Vapor Only X = Vapor & Liquid	3=Undersized by 2 4=Undersized by 1 5=Nominal 6=Oversized by 1	K=w/cast iron J=1215/1216 RMF	OEM = OEM RMF= Remanufactured
BJ	O	C		
Motor Voltage	Start Method	Control Voltage		
AK=200/3/60 AM=220/3/50 BJ=400-460/3/50-60 BK=200-230/3/50-60 CA=500-575/3/50-60 CS=346-400/3/50-60 CU=415-480/3/50-60	O=2 Step Double Delta	C=115/1/50-60 J=230/1/50-60		

CSH7573-70Y-4PU

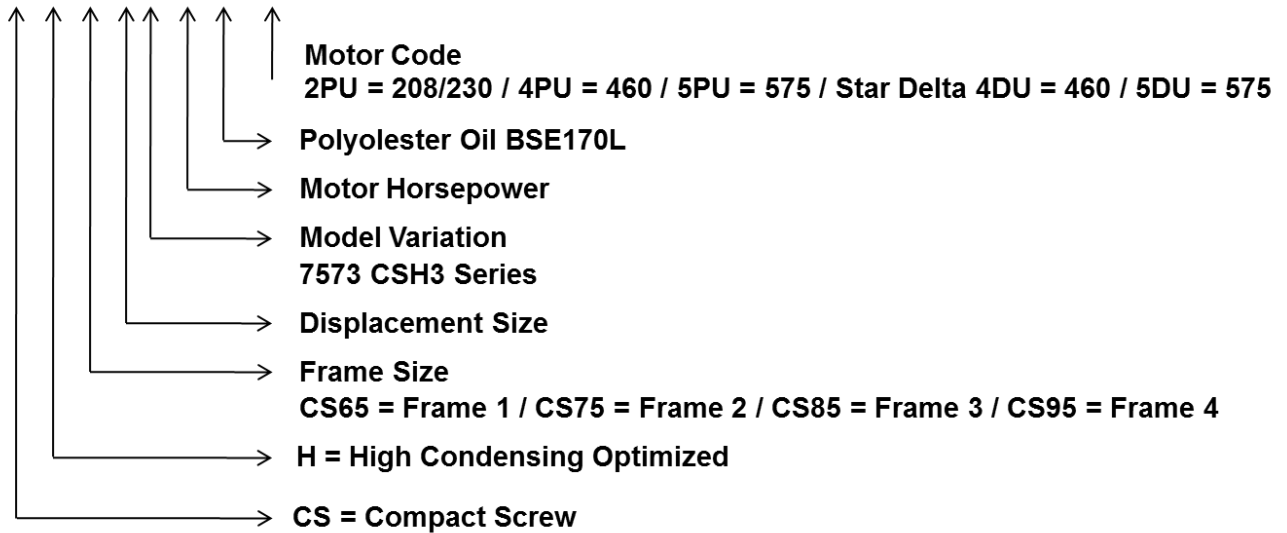

“Y” after the 11th Digit is Oil Type (when required)

“Y” = BSE170 for HFC’s / If no “Y” in Model Number = B320SH for R22

CSW7573-70Y-4PU

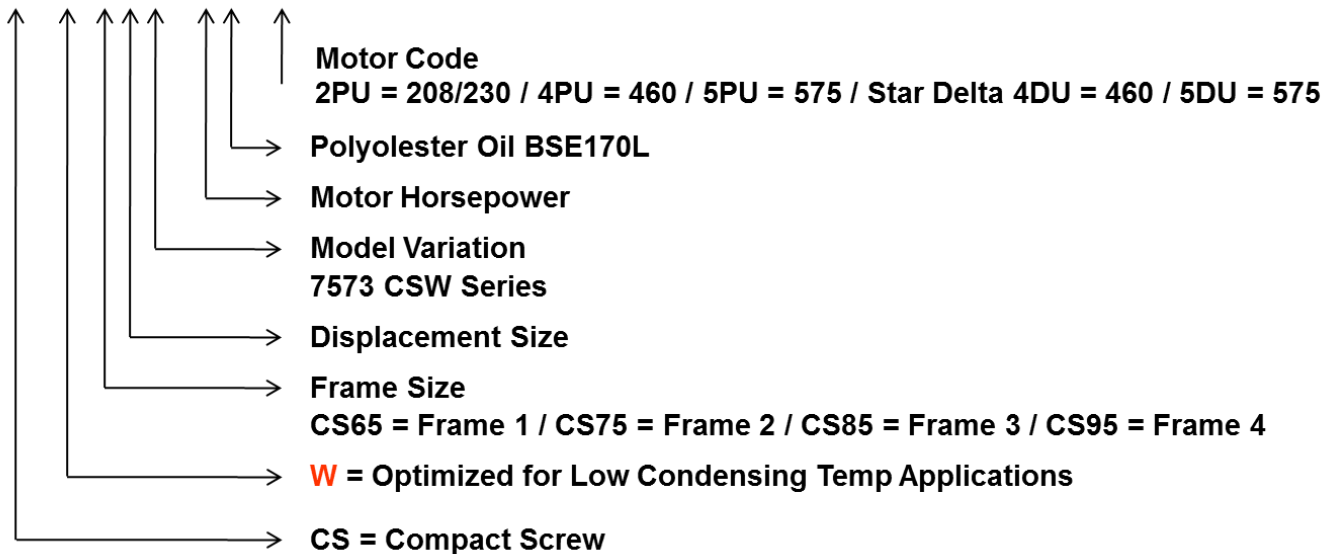

To aid in the conversion from a Dunham-Bush (Hartford Compressor) Vertical Screw Compressor to a Bitzer Screw Compressor the following information has been assembled.

For replacement compressor selection a capacity comparison of each compressor is given for review. Dimensional information is also provided for the Dunham Bush compressors.

The suction and discharge connections are different between the Dunham-Bush and the Bitzer compressors.

The Dunham Bush Screw has the suction valve located on the suction boss on the side of the compressor. The discharge valve is located on top of the compressor at the discharge boss for the Dunham-Bush 127mm J versions, 127mm K versions, 102mm J versions and 110mm L versions. The Dunham-Bush 110mm K version relocated the discharge port to the side of the upper enclosure making the discharge horizontal instead of vertical. The Bitzer compressor service valves are located on the top for the CSH6553-50 through the CSH8573-140. The suction valve connection is located on the end for the CSH9553-180 through the CSH9573-240. The connection sizes are also different and the size information supplied.

The weights of the compressors are similar and listed for comparison.

The control wiring for these compressors also has some differences.

The Dunham-Bush standard module included with new compressors is the Kriwan INT369R compressor protection module where the control circuit is wired through terminals M1 and M2 and module power is connected to L1 & L2.

The Dunham-Bush motor protector has four motor temperature sensors (thermistors) embedded in the motor windings wired in parallel to the controller.

The Bitzer CSH series utilizes a SE-E1 electronic module.

The control circuit is wired through terminals 11 & 14 and module power is connected to L & N.

There is an additional connection on the SE-E1 electronic module at terminal 12. This can be used to indicate a general compressor fault.

The Bitzer temperature sensors (thermistors) are embedded in the motor windings and are wired in series (T1 and T2) with the discharge gas temperature sensor into the SE-E1.

The loading and unloading of the compressors is slightly different. The Dunham-Bush compressor can be loaded or unloaded anywhere from 20% to 100% load. The Dunham-Bush compressor can also be held at any part load condition desired by the controller. The Bitzer CS series of compressors can be applied in various configurations with No modification to the compressor required. Depending on the number of capacity solenoids used, the compressor can be applied either 4 step capacity control (25, 50, 75 and 100% control), 25 to 100% Infinite capacity control where only 2 of the solenoids are used and even 3 Step capacity control where only 3 of the solenoids are used generally with a 50% minimum. By pulsing these solenoids back and forth, any part load condition can be achieved between 25% to 100% load.

In applications where reduced voltage starting is used the Dunham-Bush compressors can utilize Part Wind or Star Delta starting which is different than the Bitzer compressors which use part winding starting for the CSH6553-50 through the CSH8573-140. The CSH9553-180 through CSH9573-240 utilizes Star Delta reduced voltage starting. Full voltage or direct on line starting is the same for both compressors.

The overload relay, wiring size and the contactors must be checked for proper sizing on all replacements.

Piping and re-configuration will have to be completed when installing the BITZER CS compressor.

Capacity Control

For the Dunham Bush Compressor		
Operation	Solenoid A	Solenoid B
Loading	On	On
Unloading	Off	Off
Hold	Off	On

For the Bitzer Screw Compressor-4-Step Capacity Control				
Operation	Solenoid 1	Solenoid 2	Solenoid 3	Solenoid 4
Start/stop	De-energized	De-energized	Energized	De-energized
Capacity 25%	De-energized	De-energized	Energized	De-energized
Capacity 50%	De-energized	Energized	De-energized	De-energized
Capacity 75%	Energized	De-energized	De-energized	De-energized
Capacity 100%	De-energized	De-energized	De-energized	Energized

For the Bitzer Screw Compressor-Infinite Capacity Control 25-100%		
Operation	Solenoid 3	Solenoid 4
Start/stop	Energized	De-energized
Loading	De-energized	Energized
Unloading	Energized	De-energized
Constant Load	Pulsing	Pulsing

Bitzer Screw Compressors Frame 2 Shown

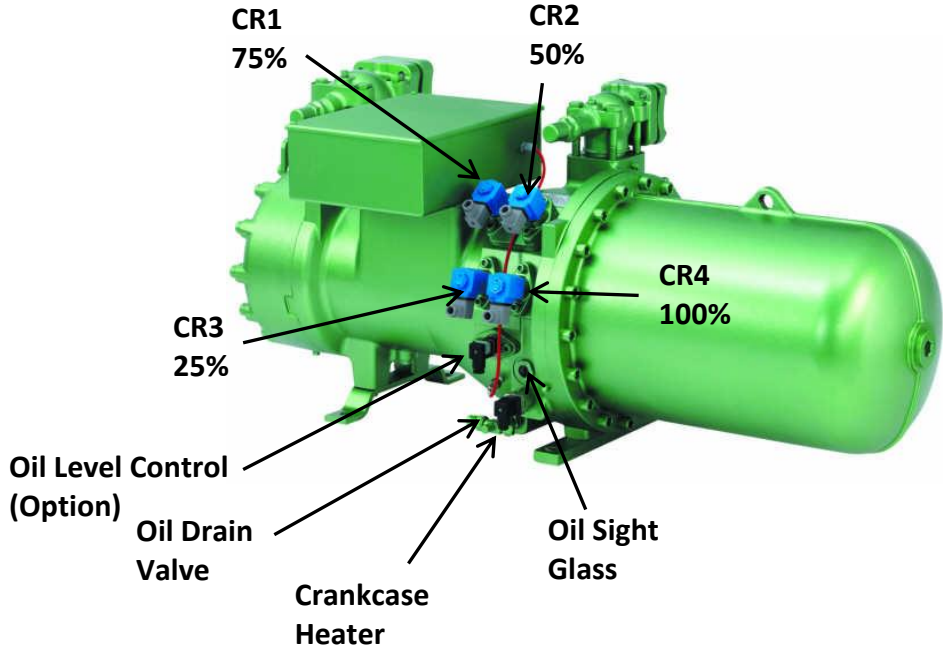

Dunham Bush MSC Series 1210, 1212, 1215, 1218

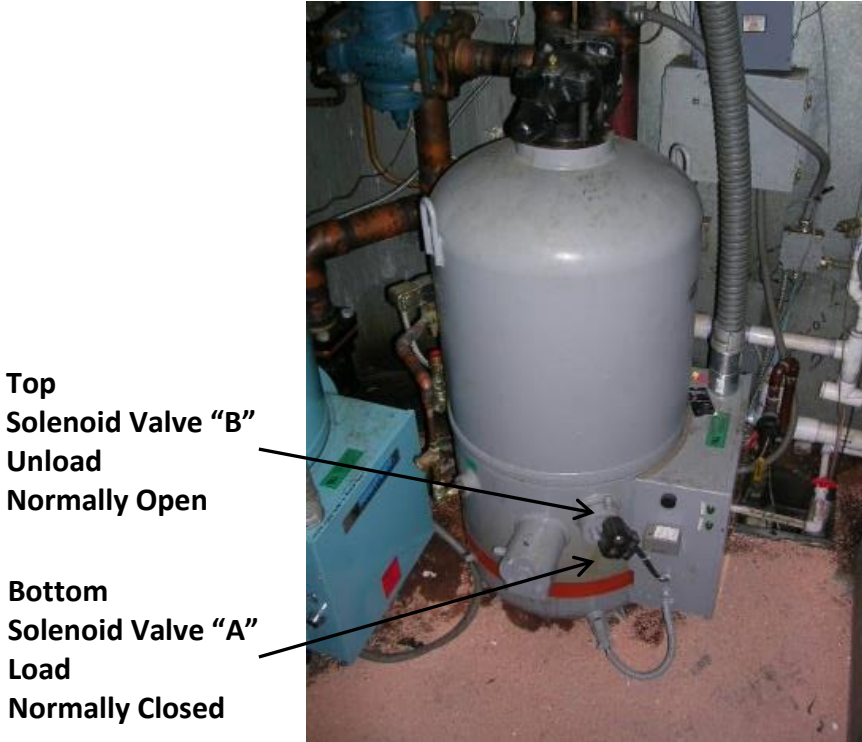

Below are various module schematics that are used on D/B compressors

TI 41AA1500E (replaced by Kriwan INT369R)

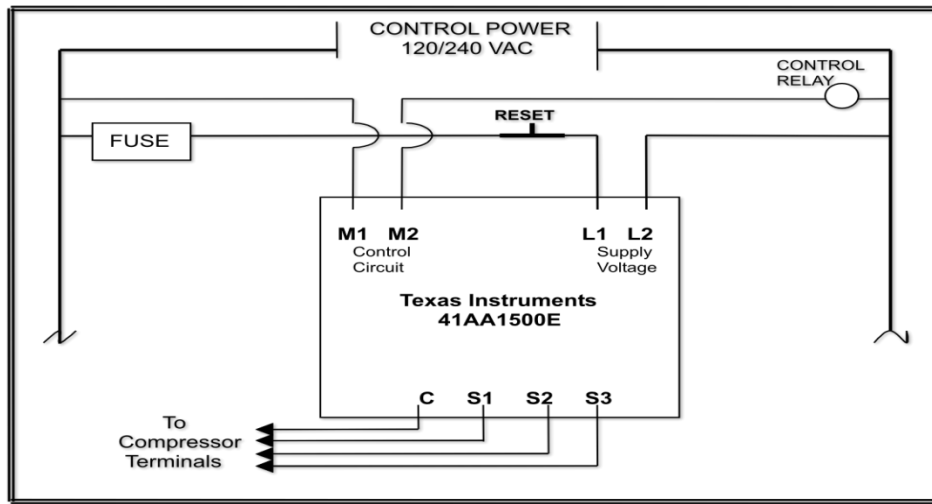

TYPICAL WIRING DIAGRAM (41AA)

TI 2ACE (replaced by Kriwan INT369R)

TI 2ACE Motor Protector Wiring Diagram

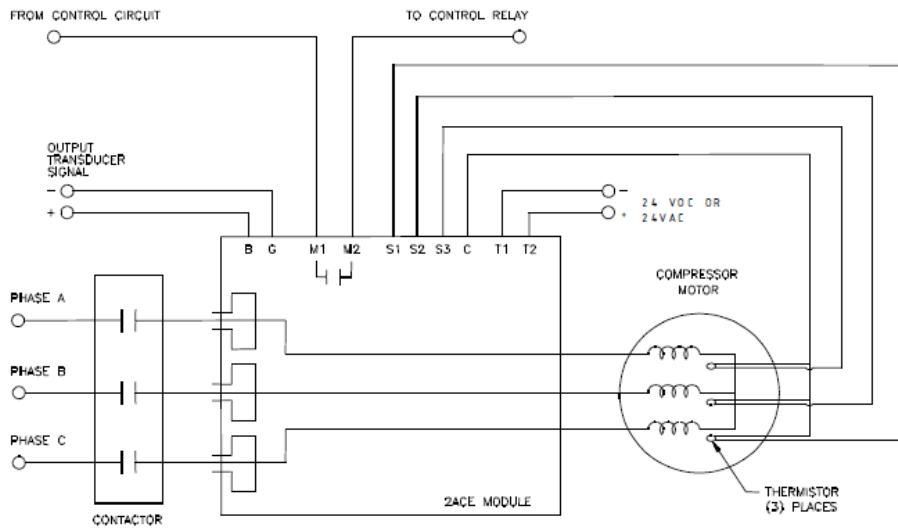

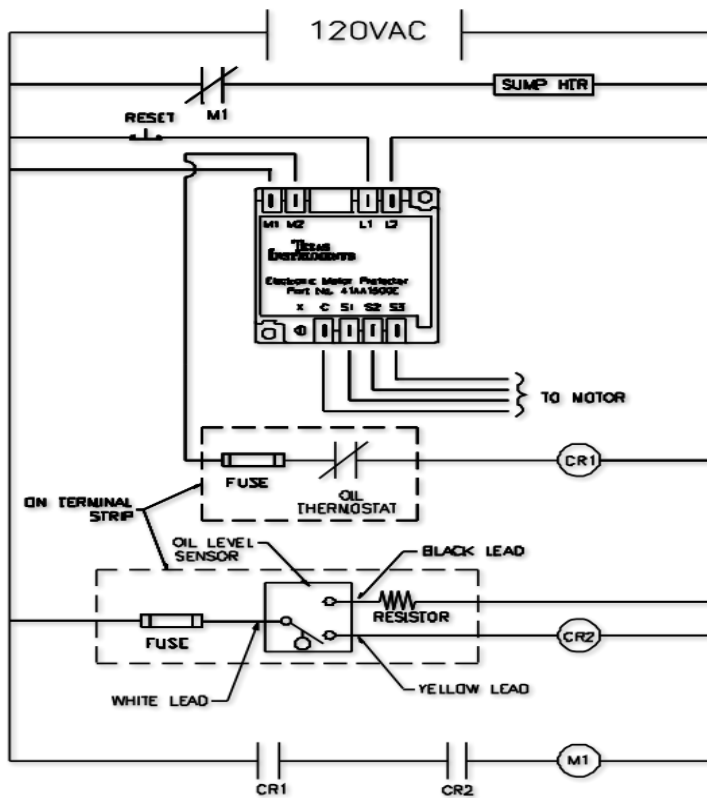

Terminal Box Decal

MEDIUM SCREW TERMINAL CONNECTIONS

ACROSS THE LINE START
ONE CONTACTOR

INCREMENT START
TWO CONTACTORS

FOUR POST TERMINAL WIRING

POWER LEAD TERMINAL TIGHTENING PROCEDURE

- INSTALL POWER LEAD TERMINAL ON STUD AND TORQUE TERMINAL LUG NUT TO VALUE IN TABLE WHILE HOLDING NUT A
- MAKE SURE THAT TERMINAL STUD DOES NOT TURN WHILE TORQUING TERMINAL LUG NUT

TERMINAL POST TORQUE SPECIFICATION

COMP. MODEL	TORQUE	
	LB-FT	Nm
110K	8	11
127J	8	11
1210K	8	11
1212K	8	11
1215K	20	27
1218K	20	27

THERMALLY PROTECTED SYSTEM

DCM 71

MSC-127 Series

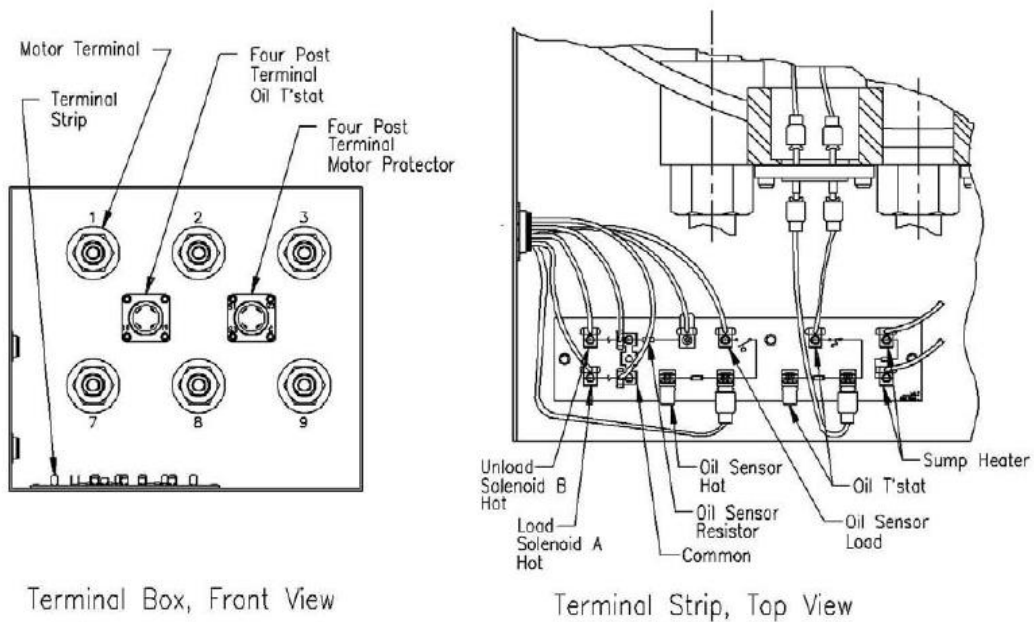

MSC-110 Series Terminal Box

Figure 6. Terminal Box

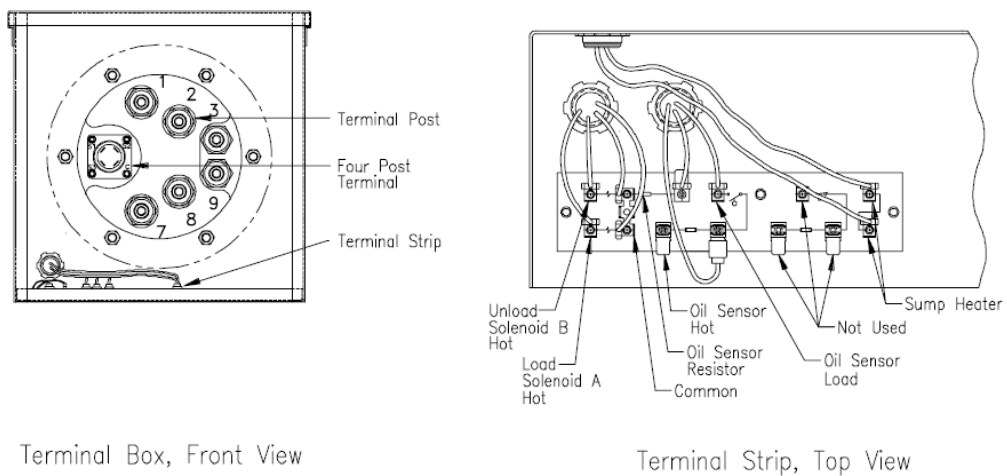

SE-E1 Electronic Module

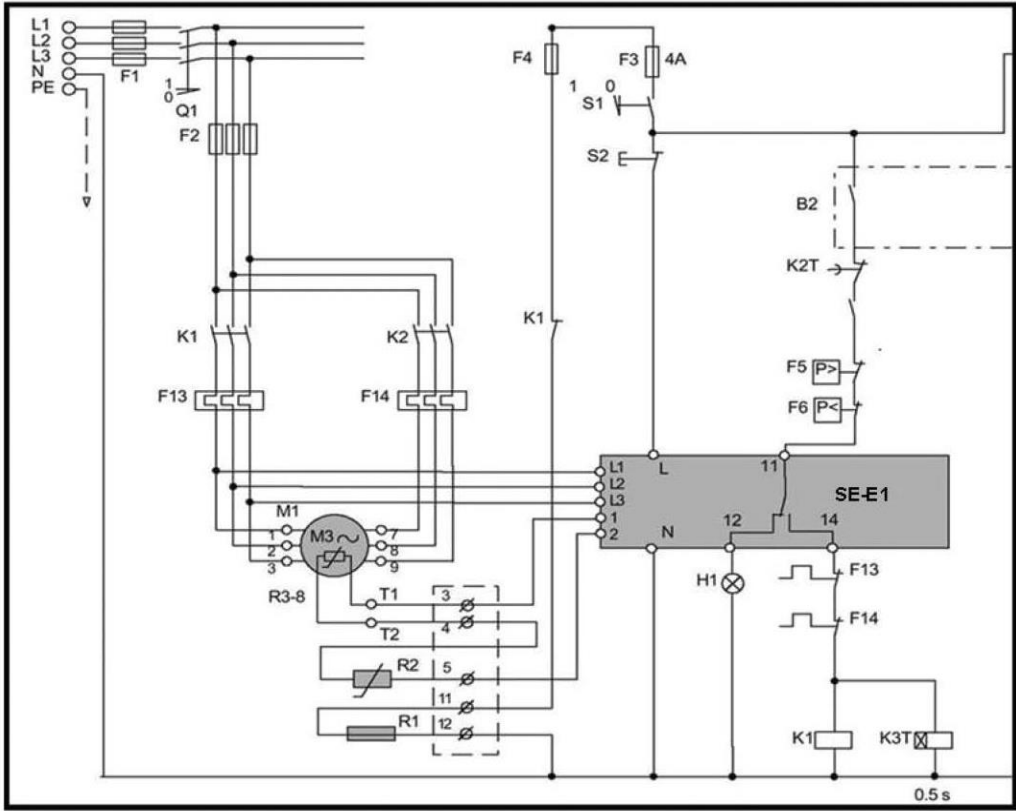
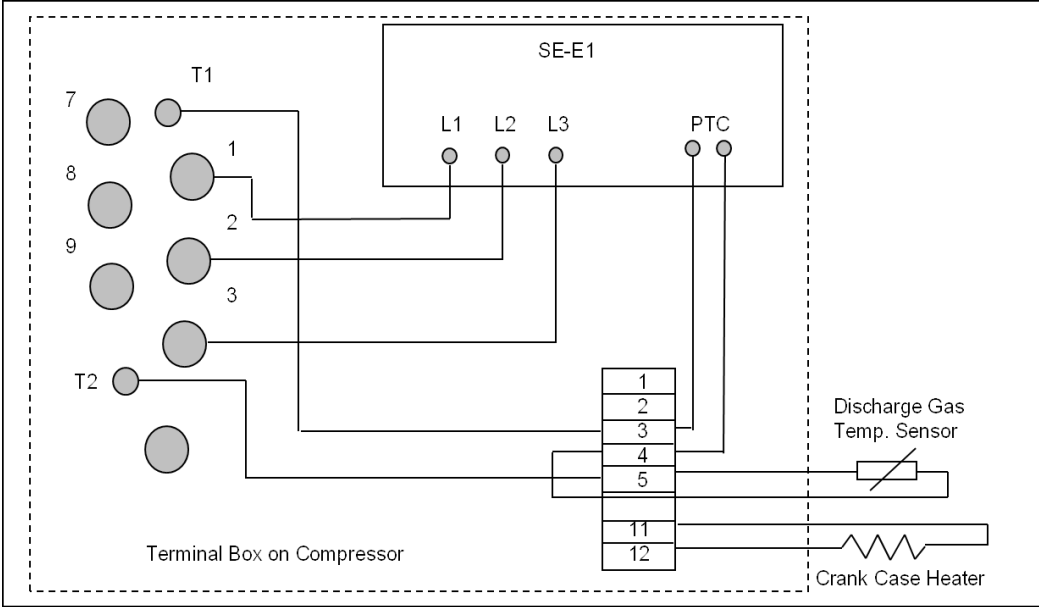

The SE-E1 is a dual voltage 115V / 230V Standard and 24V AC is available as an option.

Each module is pre-wired inside the terminal box. The module monitors discharge gas / oil temperature via a PTC sensor. The module also monitors motor winding temperature via the motor sensors embedded into the motor windings which are wired in series and connected to the module. Phase sequence control for direction of rotation is also monitored.

As mentioned above, each module is pre-wired inside the terminal box. The following connections should be checked for tightness.

Voltage / Phase Connections:

L-1 (black) connected to L-1 spade connection on the terminal plate.

L-2 (brown) connected to L-2 spade connection on the terminal plate.

L-3 (blue) connected to L-3 spade connection on the terminal plate.

Note: Each lead is identified at the plug connector with number markings and can also be found laser etched on the front of the module.

Motor Winding Temperature Connections:

T-1 (brown) connected to number 1 on the module.

T-2 (brown) connected to position 5 on the connector strip.

Discharge Gas / Oil Temperature Sensor PTC120:

The blue wire is connected to the opposite side of position 5 with the T-2 connection.

The brown wire connected to number 2 on the module.

Compressor Control Circuit is wired through terminal 11 and 14.

Terminal 12 can be utilized as a general compressor fault output. It will be powered whenever the module trips.

The last thing that needs to be checked is starting. In applications where reduced voltage starting is used the Hartford D/B use Part Winding Start or have a Star - Delta starter which is different than the BITZER CS compressor.

BITZER CS compressors utilize Part Winding Start or Direct on Line on all CS65, 75 and 85 compressors and Star Delta reduced voltage starting on the CS95 series. Full voltage or direct on line starting is the same for both compressors.

The overload relay and the contactors must be checked for proper sizing.

Oil Types			
D/B - Hartford	All Series	R22 Oil	4GS Mineral
Bitzer	CSH Series	R22 Oil	CPI4214-320

MSC 110mm COMPRESSOR OUTLINE DRAWING

110MM "L" VERSION
DIMENSIONAL OUTLINE

MODEL	A	B
1111	14.38	12.79
1113	15.07	12.82
1117	14.25	11.63

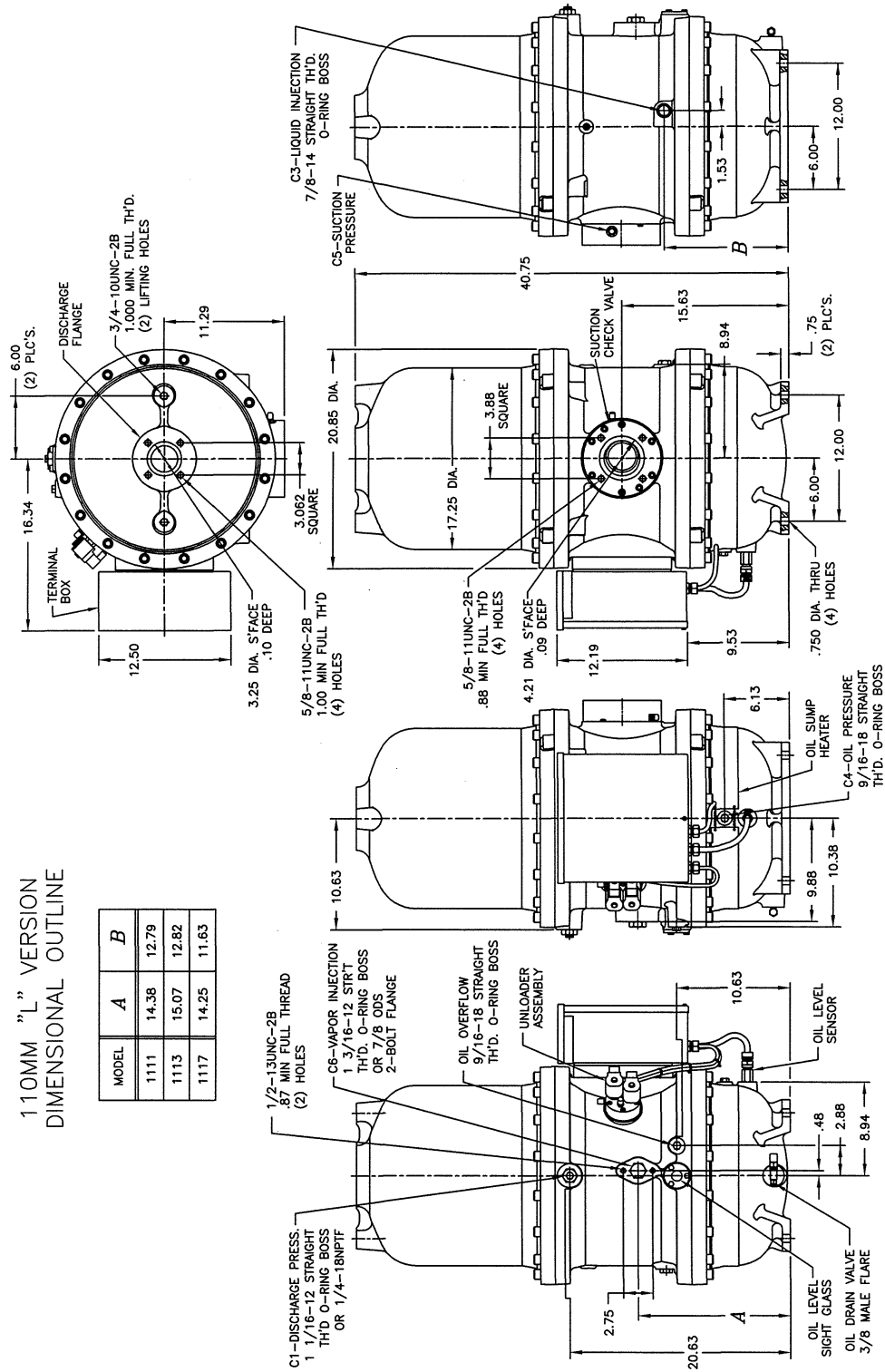

MSC 127mm COMPRESSOR OUTLINE DRAWING

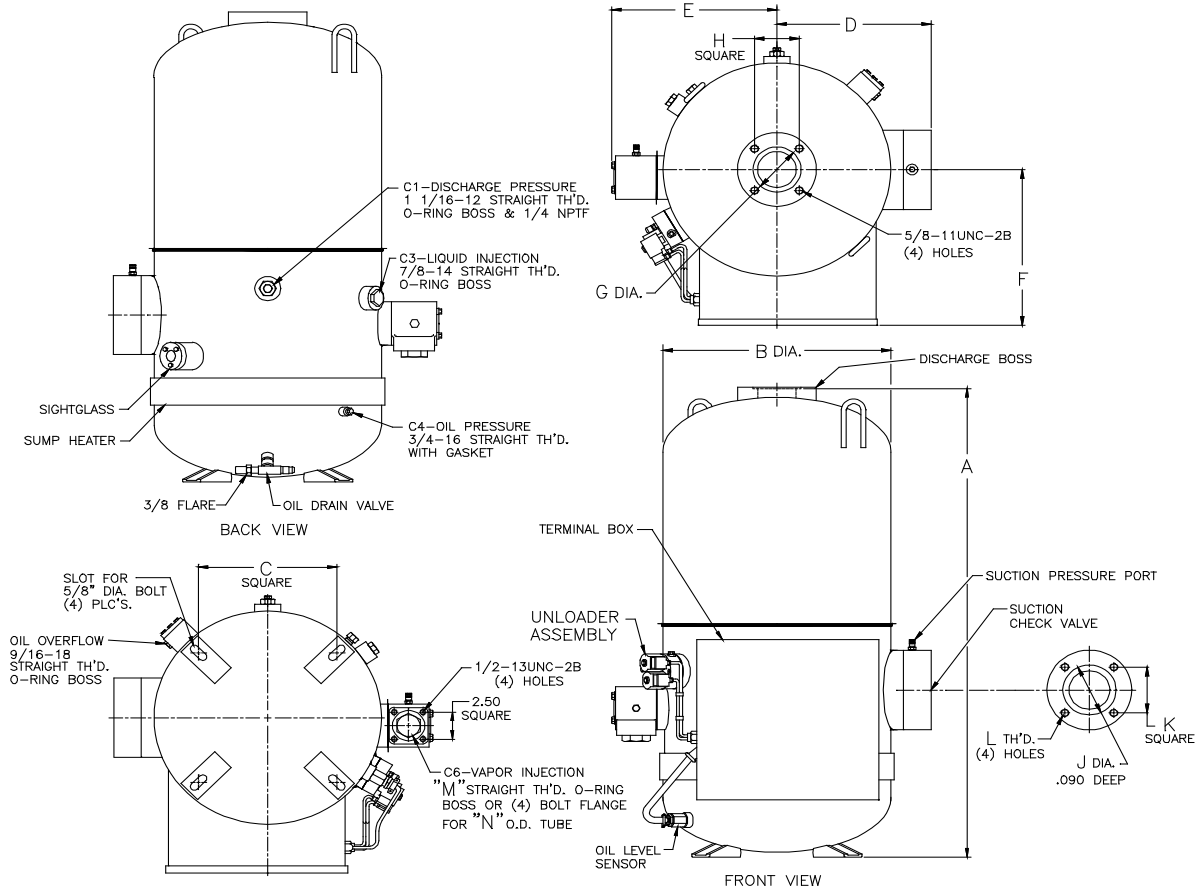



**Post and Pre Pictures of Bitzer CSH7573-90-4PU
Replaced Hartford Dunham Bush
Vertical Screw Compressor 1117NHF6X6K**



1215NHF6W4KBJ to CSH8561-125-4PU



1215NHF6W4JBJOC to BITZER CSH8573-140-4PU



Bitzer CSH						
Model Number	Dimensions L x W x H (in)			Disch. Conn. (in)	Suction Conn. (in)	Shipping Weight (lb)
CSH6553-50	43.57	22.13	22.44	1 5/8	2 1/8	671
CSH6563-60	43.57	22.13	22.44	1 5/8	2 1/8	693
CSH7553-70	52.94	22.25	24.19	2 1/8	3 1/8	1058
CSH7563-80	52.94	22.25	24.19	2 1/8	3 1/8	1076
CSH7573-90	52.94	22.25	24.19	2 1/8	3 1/8	1091
CSH8553-110	60.63	27.8	29.19	3 1/8	4 1/8	1749
CSH8563-125	60.63	27.8	29.19	3 1/8	4 1/8	1762
CSH8573-140	60.63	27.8	29.19	3 1/8	4 1/8	1784
CSH9553-180	72.19	27.63	33.26	3 1/8	4 1/8	2734
CSH9561-210	72.19	27.63	33.26	3 1/8	4 1/8	2778
CSH9573-240	72.19	27.63	33.26	3 1/8	4 1/8	2800
CSH9583-280	72.71	26.73	34.17	4 1/8	5.00	3043
CSH9593-300	72.71	26.73	34.17	4 1/8	5.00	3087
Compressor is with the Suction and Discharge Service Valves						

CSH Model Data			
Model Number	CFM DISPL 60Hz	CFH DISPL 60Hz	Motor HP
CSH6553-50	97	5830	50
CSH6563-60	121	7244	60
CSH7553-70	140	8410	70
CSH7563-80	161	9682	80
CSH7573-90	183	10989	90
CSH8553-110	224	13428	110
CSH8563-125	255	15300	125
CSH8573-140	292	17491	140
CSH9553-180	380	22802	180
CSH9561-210	437	26212	210
CSH9573-240	497	29835	240
CSH9583-280	572	34310	280
CSH9593-300	646	38786	300

CSH / CSW Screw Accessories

Crankcase Heater - Special Voltage Heater		Pressure Controller with 1/4" NPT Transducer Sensor	
Part # (Voltage)	Model	Kit Part #	
343213-07 (230V)(200W)	(CS 65 - CS 75)	999-0005-01	
343213-02 (230V)(300W)	(CS 85 - CS 95)		
Oil Level Control - Mechanical (CSH Series)		Temperature - Strap On Sensor with Capacity Controller	
Part #	Model	Kit Part #	
347403-05	(CSH 65)	999-0003-01	
347403-03	(CSH 75 - CSH 85)		
347403-06	(CSH 95)		
Oil Level Control - Electronic (CSH Series)		Temperature - 1/4" NPT Insert Sensor with Capacity Controller	
Part #	Voltage	Kit Part #	
347962-02	115V	999-0004-01	
347962-01	230V		
347962-03	24VAC		
Liquid Injection Adapter Kit			
Part #			
361332-10			
Liquid Injection Controller			
Part #			
085-0164-17			
Economizer Adapter			
Model:	Part #		
CS65	361329-16		
CS75	361329-16		
CS85	361330-05		
CS95	361330-07		

BITZER Oils for CS Series		
Model	Refrigerant	Oil
CSH	R22	B320SH
	R134a/R407C/R404A/R507A	BSE170
CSW	R22	B320SH
	R134a	BSE170L

B320SH Polyolester Oil	
Unit of Measurement	Part #
1 gallon	793-3320-01
5 gallon	793-3320-34

BSE 170 Polyolester Oil	
Unit of Measurement	Part #
1 gallon	793-1170-34
5 gallon	793-3170-34

BSE 170 L Polyolester Oil	
Unit of Measurement	Part #
1 liter	915118-06
5 liter	915118-01
10 liter	915118-02

BITZER CSH Screw Compressor Dimensional Data

CSH65

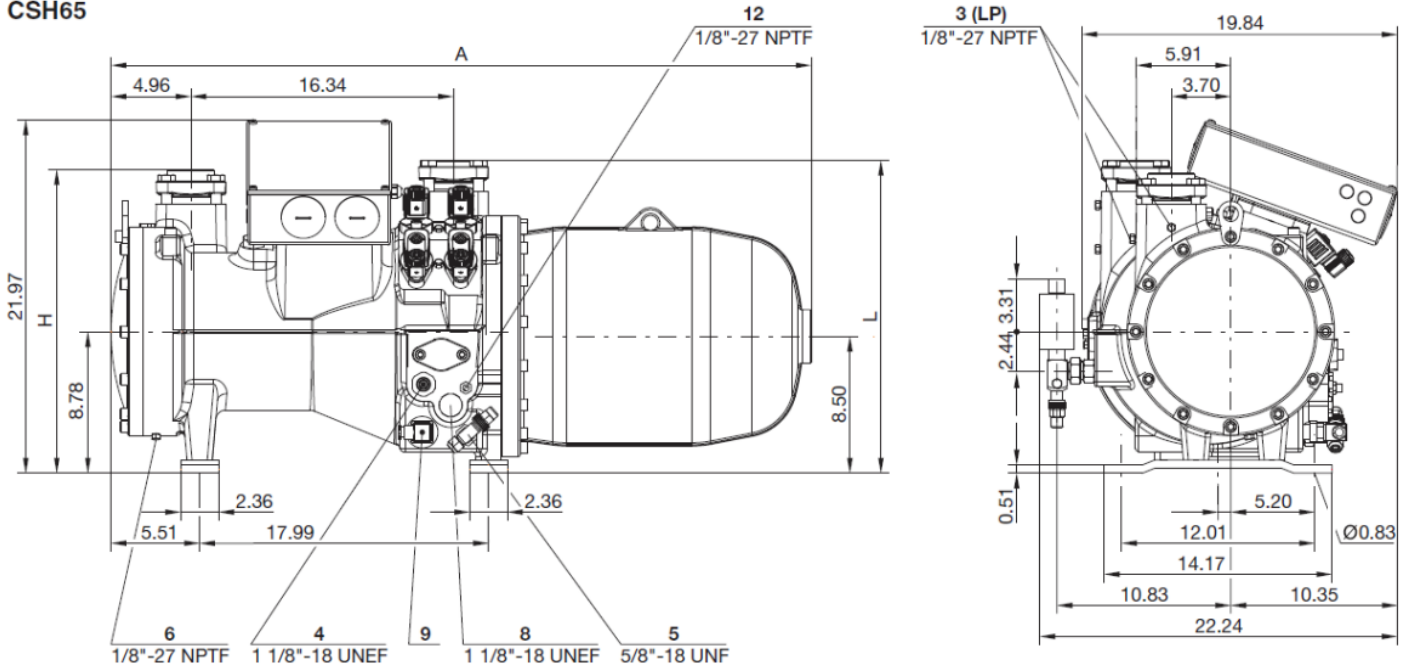

CSH75

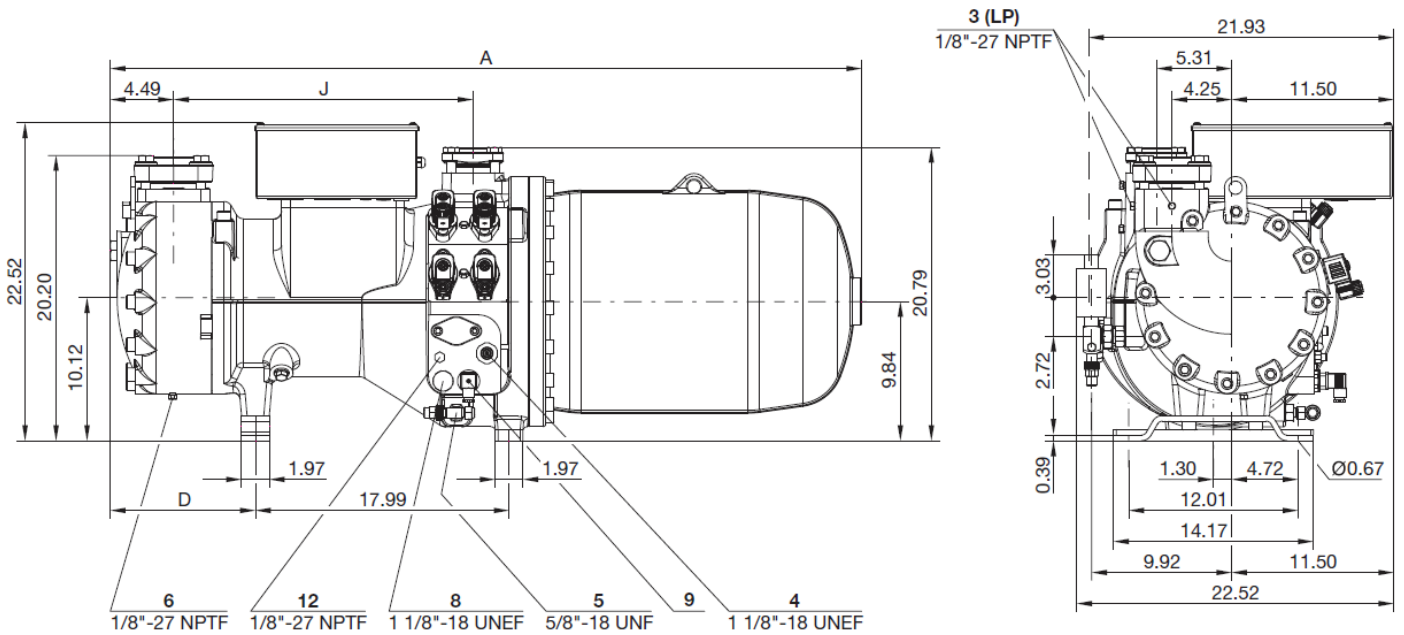

CSH85

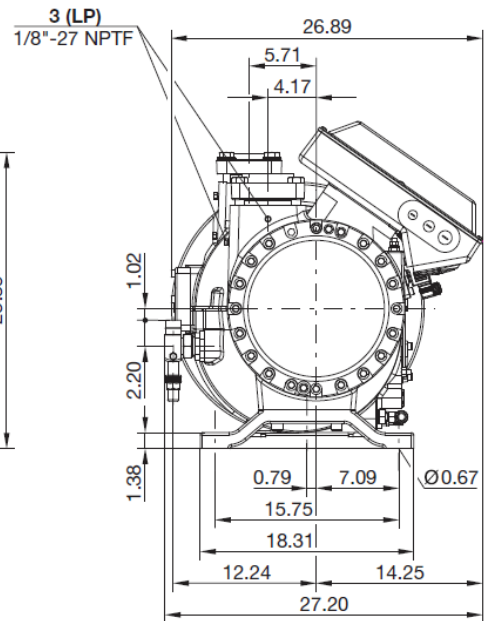
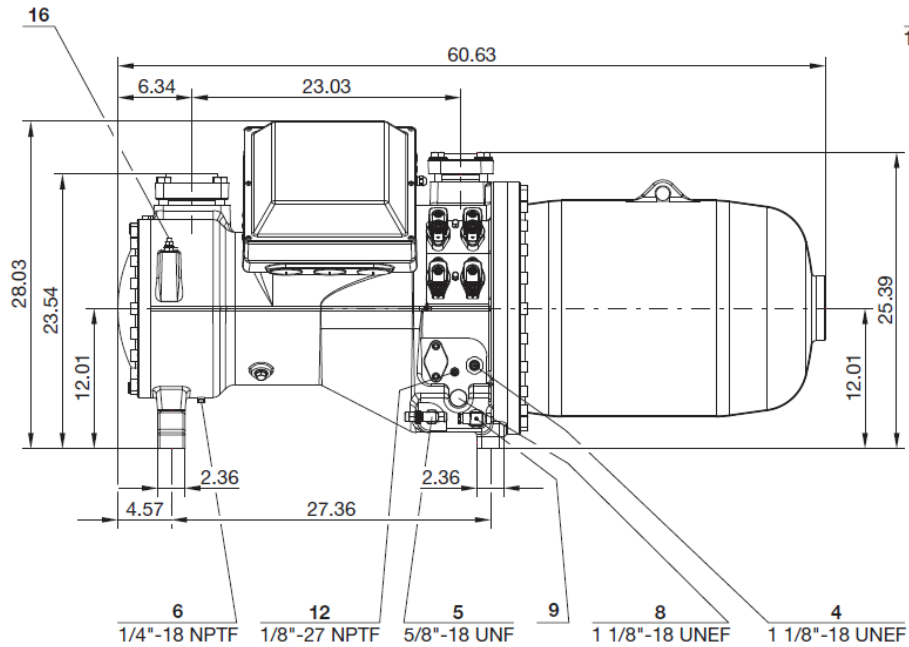

CSH95

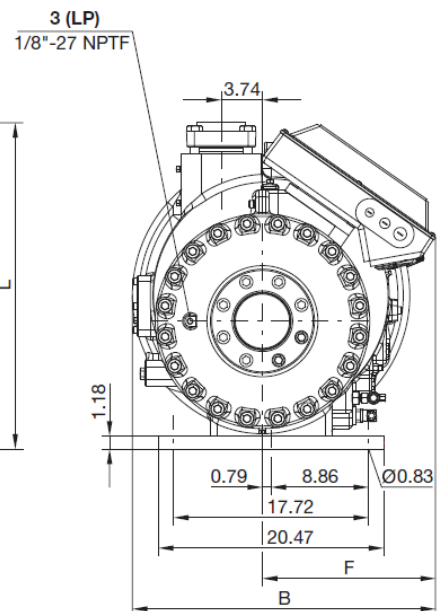
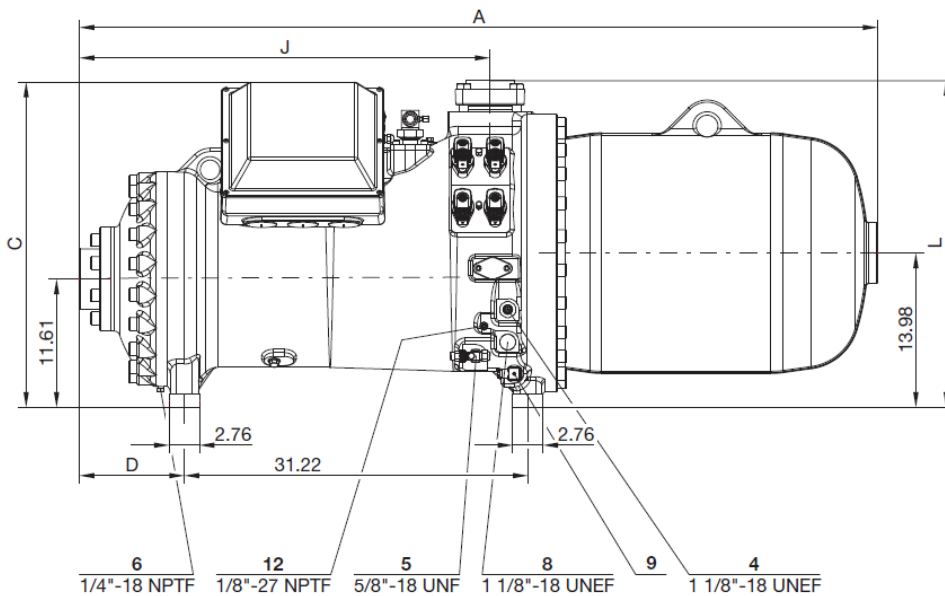



NOTES

Please Note:

The advice given herein and/or any conclusions made by BITZER US, Inc. represent BITZER US, Inc.'s best advice and judgment under the circumstances, but such advice and/or conclusions made or results obtained shall be deemed used at your sole risk. For further assistance, please contact our application engineering department using the contact information on the back page of this booklet.



BITZER Competitive Replacement Inquiry

Date: _____

Name	
Company Name	
Address	
City, State, Zip	
Phone	
Cell Phone	
Email	
Customer's Name	
Address	

Brand of the compressor you are replacing: _____

Compressor Model No.: _____ Serial No.: _____

System Manufacturer (OEM) and Unit Model #: _____

Please specify single circuit or compressor is in parallel: _____

Type of refrigerant used: _____ Tonnage requirement: _____

Operating condition: Evaporating: _____

Condensing: _____

Suction superheat: _____

Subcooling: _____

Voltage: _____

Reason for replacement: _____

How many compressors are you looking to replace?: _____

Please provide any additional comments: _____