Hanbell RC Series to BITZER CSH

Competitive Replacement Guideline

XR-0018-01 01/13



BITZER Screw Compressors CS High Temp Series

The intention of this document is to serve as general guidelines. The information contained is not intended to replace specific equipment and/or system manufacturer's information or guidelines. BITZER implies no liability for the information contained. It is BITZER's implicit intention that nothing contained in this guide replaces any past, present or future warranty policy of BITZER and/or any other manufacturer's equipment

These guidelines are supplied as a recommended procedure for troubleshooting the CS screw compressor

These guidelines are not a replacement for information specific to that of the manufacturer or the manufacturer's system technical product information.

Each system may vary in design, usage and specifications. This document is intended for use specific to the compressor only and not intended to be a "catch all" for any and every possible application of the compressor.

BITZER's intention is that only qualified and certified (where applicable) individuals specific to the refrigeration industry use the information contained and all standard refrigeration handling and safety practices must be followed at all times.

BITZER's intention is that all electric work is performed by qualified and certified (where applicable) individuals and all standard electrical safety practices must be followed at all times.



WARNING

This icon indicates instructions to avoid personal injury and material damage



CAUTION

This icon indicates instructions to avoid property damage and possible personal injury



HIGH VOLTAGE

This icon indicates operations with a danger of electric shock

Table of Contents

Scope of Delivery BITZER CS and Hanbell RC Series	2
Capacity Comparison Hanbell RC Series and BITZER CSH-CSW Series	3
BITZER CSH and CSW Capacity Comparison	4
CFH Ratings	5
Horsepower Ratings	6
Model Number Nomenclature RC to RC2 Models	7
Model Number Nomenclature BITZER CSH and CSW	8
Overview	9
Module Types and Wiring	10-14
Capacity Control	15-18
Oil Types	19
Connection Sizes	20-21
RC2-100 thru RC2-180 and RC2-170 thru RC2-620 Dimensions	22
RC2-610 thru RC2-930 and RC2-1090 thru RC2-1520 Dimensions	23
CSH / CSW Accessories	24
CSH / CSW Oil Part Numbers	25
CSH Drawings	26-27
Competitive Replacement Request Form	29

Scope of Standard Delivery (as supplied by Manufacturer)	Bitzer CSH	Hanbell RC
Capacity control system : 4-Steps or Infinite Continuous (See Below)	No Modification Req	Δ
25% to 100% Capacity Control	●	
Conversion Kit Stepped to Stepless Control	Not Required	Δ
4 Step Capacity Control	●	Δ
Infinite Capacity Control	●	Δ
Solenoid coils for capacity control	●	Δ
Volume ratio Vi, Option Vi=2.2, 2.6, 3.0, 3.5	Built In	Δ
Discharge Check Valve	● Internal	Δ External
Suction Coupling tube and/or Flange	N/A	●
Discharge Coupling tube and/or Flange	N/A	●
Suction Service Valve	●	Δ
Discharge Service Valve	●	Δ
Suction service valve location	Top	End
Discharge service valve location	Top	Top
Oil Charge	●	Δ
Electronic Module (Rotation)	●	Δ
Electronic Module (Temperature)	●	●
PTC100 type temperature sensor	N/A	●
PTC120 type temperature sensor	●	N/A
PT100 type motor temperature sensor	PTC Sensors	●
PTC110 type temperature sensor	N/A	N/A
Screw in Discharge temperature sensor	● (251F)	● (212F)
IP-54 Terminal box	●	●
Crankcase oil heater	●	●
Compress chamber (Middle side) liquid inject port	●	Δ
Motor side (Low side) liquid inject port	Not Required	Δ
Economizer port	●	●
Oil cooling connection	●	●
Liquid injection oil cooling port	●	●
Oil drain valve	●	●
Oil level switch	Δ	Δ
Oil filter different pressure (ΔP) protector switch	Not Required	Δ
Liquid injection expansion valve	N/A	Δ
Liquid injection solenoid valve	N/A	Δ
Safety Valve	● Internal	Δ
Position sensor (Capacity control)	N/A	Δ
Slide fit motor	●	No
Starting type PWS	●	No
Starting type Start Delta	Δ	●
Jumper bars for DOL starting	●	Δ
Rubber mounting pads	●	Δ
Oil Separator	Intregal	Intregal
	● (Standard) Δ (Option) N/A Not Applicable	

Hanbell RC Series

Recommended Replacement Model Chart			
BITZER CSW Low Condensing Series / CSH Series			
Bitzer Screw Compressor		Hanbell RC (Vi 2.2)	
Compressor	Tons	Compressor	Tons
CSH6553-50	48	RC2-100B	36
CSH6553-50	48	RC2-140B	49
CSH6563-60	60	RC2-170B	62
CSH6563-60	60	RC2-180B	65
CSH7553-70	70	RC2-200B	70
CSW6593-60	84	RC2-230B	88
CSH7573-90	98	RC2-260B	94
CSW7583-80	116	RC2-300B	111
CSW7583-80	116	RC2-310B	117
CSW7583-80	116	RC2-320B	121
CSW7593-90	132	RC2-340B	128
CSH8563-125	134	RC2-370B	139
CSH8573-140	156	RC2-410B	153
CSW8583-125	179	RC2-470B	182
CSW8593-140	202	RC2-510B	192
CSH9553-180	207	RC2-550B	210
CSH9563-210	240	RC2-580B	228
CSH9563-210	240	RC2-610B	234
CSH9563-210	240	RC2-620B	237
CSH9573-240	276	RC2-710B	273
CSH9583-280	309	RC2-790B	303
CSW9583-210	323	RC2-830B	326
CSW9593-240	365	RC2-930B	364
CSW95103-280	393	RC2-1020B	407
		RC2-1090B	446
Based on 45/105/9/9 R22			

BITZER CSW and CSH Model Comparison			
BITZER CSW Low Condensing and CSH Standard Series			
Bitzer CSW Screw		Bitzer CSH Screw	
BITZER Number	Tons	Model Number	Tons
CSW6583-50	74	CSH6553-50	48
CSW6593-60	84	CSH6563-60	60
CSW7573-70	102	CSH7553-70	70
CSW7583-80	116	CSH7563-80	82
CSW7593-90	132	CSH7573-90	98
CSW8573-110	163	CSH8553-110	118
CSW8583-125	179	CSH8563-125	134
CSW8593-140	202	CSH8573-140	156
CSW9563-160	248	CSH9553-180	207
CSW9573-180	283	CSH9563-210	240
CSW9583-210	323	CSH9573-240	276
CSW9593-240	365	CSH9583-280	309
CSW95103-280	393	CSH9593-300	350
Based on 45/105/9/9 R22			

CFH Rating	
Hanbell RC	
Model Number	CFH 60Hz
RC2-100B	4140
RC2-140B	5820
RC2-170B	7320
RC2-180B	7620
RC2-200B	8220
RC2-230B	9780
RC2-260B	10920
RC2-300B	12420
RC2-310B	13080
RC2-320B	13560
RC2-340B	14400
RC2-370B	15540
RC2-410B	17280
RC2-470B	20040
RC2-510B	21600
RC2-550B	23280
RC2-580B	24780
RC2-610B	25980
RC2-620B	26280
RC2-710B	30300
RC2-790B	33600
RC2-830B	35040
RC2-930B	39420
RC2-1020B	43280
RC2-1090B	46260

CFH Rating Model Chart			
BITZER CSW Low Condensing and CSH Standard Series			
Bitzer CSW Screw		Bitzer CSH Screw	
BITZER Number	CFH 60Hz	Model Number	CFH 60Hz
CSW6583-50	8299	CSH6553-50	5830
CSW6593-60	9323	CSH6563-60	7244
CSW7573-70	10989	CSH7553-70	8410
CSW7583-80	12572	CSH7563-80	9682
CSW7593-90	14338	CSH7573-90	10989
CSW8573-110	17491	CSH8553-110	13428
CSW8583-125	20024	CSH8563-125	15300
CSW8593-140	22602	CSH8573-140	17491
CSW9563-160	26212	CSH9553-180	22802
CSW9573-180	29835	CSH9563-210	26212
CSW9583-210	34310	CSH9573-240	29835
CSW9593-240	38786	CSH9583-280	34310
CSW95103-280	43261	CSH9593-300	38786

Hanbell RC	
Model Number	Motor HP
RC2-100B	38
RC2-140B	50
RC2-170B	63
RC2-180B	66
RC2-200B	70
RC2-230B	81
RC2-260B	90
RC2-300B	107
RC2-310B	110
RC2-320B	114
RC2-340B	121
RC2-370B	130
RC2-410B	146
RC2-470B	170
RC2-510B	183
RC2-550B	195
RC2-580B	210
RC2-610B	214
RC2-620B	220
RC2-710B	250
RC2-790B	276
RC2-830B	290
RC2-930B	334
RC2-1020B	360
RC2-1090B	402

Nominal Horse Power (HP) –
All above models' Nominal HP
are not equal to the maximum
compressors HP

Bitzer CSW	
Model Number	Motor HP
CSW6583-50	50
CSW6593-60	60
CSW7573-70	70
CSW7583-80	80
CSW7593-90	90
CSW8573-110	110
CSW8583-125	125
CSW8593-140	140
CSW9563-160	160
CSW9573-180	180
CSW9583-210	210
CSW9593-240	240
CSW95103-280	280

Bitzer CSH	
Model Number	Motor HP
CSH6553-50	50
CSH6563-60	60
CSH7553-70	70
CSH7563-80	80
CSH7573-90	90
CSH8553-110	110
CSH8563-125	125
CSH8573-140	140
CSH9553-180	180
CSH9563-210	210
CSH9573-240	240
CSH9583-280	280
CSH9593-300	300

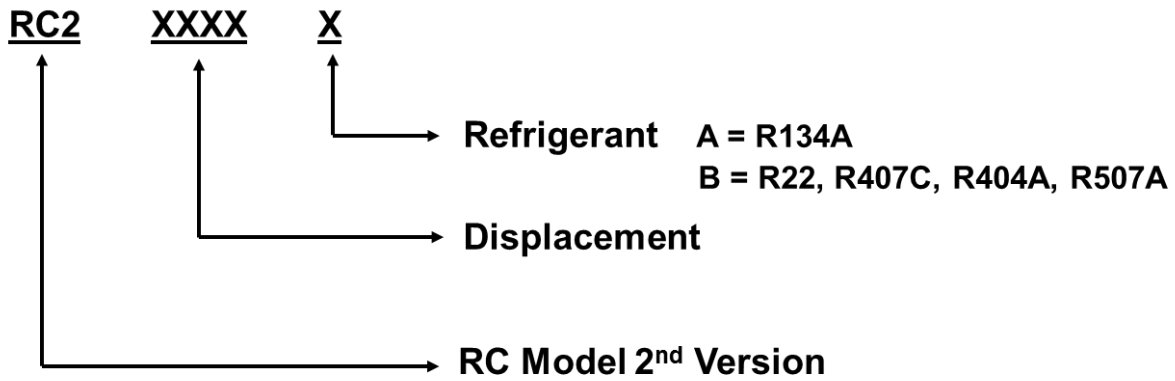

RC to RC2 Model Number	
New Model	Old Model
RC2-100B	RC10
RC2-140B	RC11
RC2-170B	RC12
RC2-180B	N/A
RC2-200B	RC13
RC2-260B	RC14
RC2-300B	RC15
RC2-310B	N/A
RC2-320B	RC15L
RC2-340B	N/A
RC2-370B	N/A
RC2-410B	RC16
RC2-470B	RC17
RC2-510B	N/A
RC2-550B	RC18
RC2-580B	N/A
RC2-610B	RC19
RC2-620B	N/A
RC2-710B	N/A
RC2-790B	RC20
RC2-830B	RC21
RC2-930B	N/A
RC2-1090B	RC22
RC2-1280B	RC23
RC2-1520B	RC24

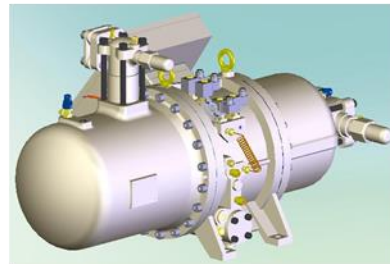

CSH7573-70Y-4PU

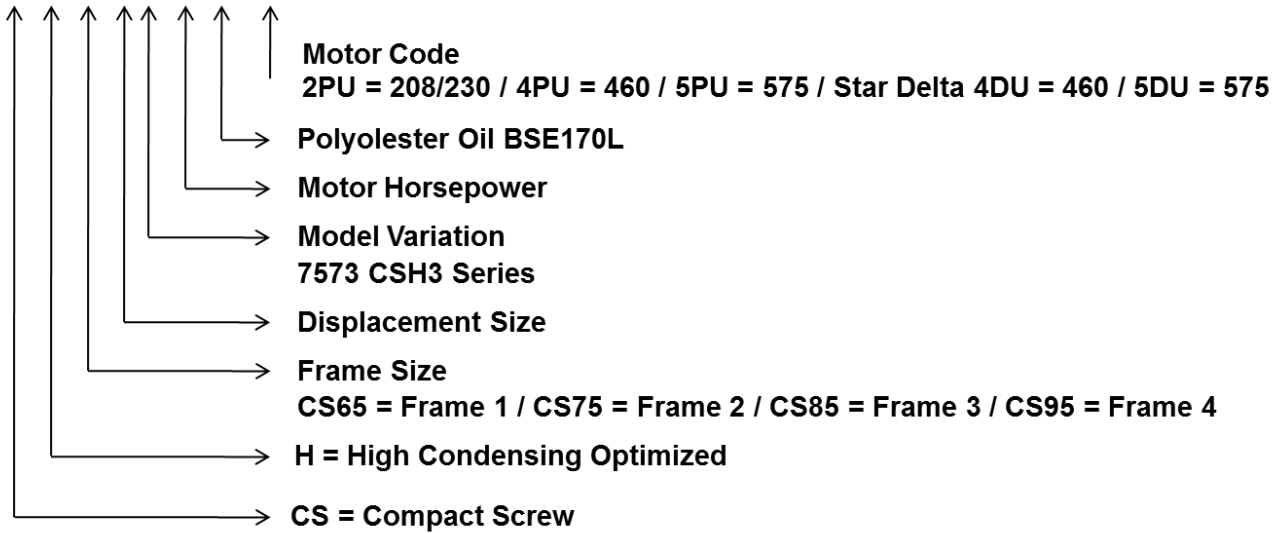

“Y” after the 11th Digit is Oil Type (when required)

“Y” = BSE170 for HFC’s / If no “Y” in Model Number = B320SH for R22

CSW7573-70Y-4PU

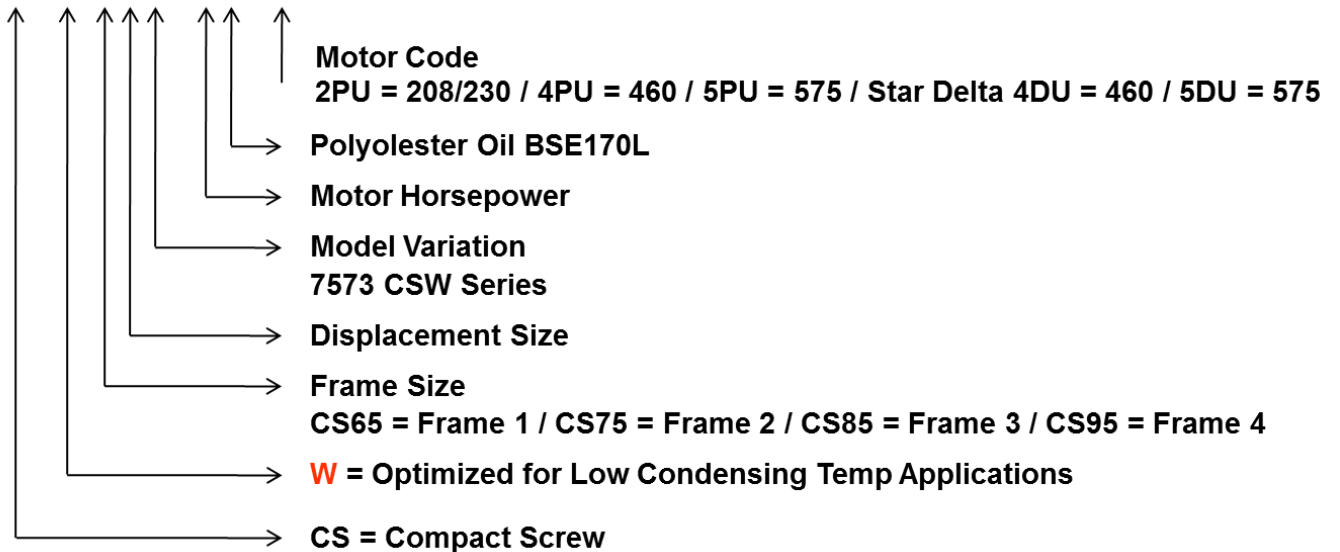

To aid in the conversion from a Hanbell RC Series Screw Compressor to a Bitzer Screw Compressor the following information has been assembled.

For replacement compressor selection a capacity comparison of each compressor is given for review. Dimensional information is also provided for the Hanbell RC compressors.

The suction and discharge connections are different between the Hanbell RC and the Bitzer compressors.

The Hanbell RC100B thru 580B and RC620B have the suction connection located on the end of the motor cover and the discharge connection located on the top.

The Hanbell RC610B thru 1520B has the suction and discharge connections located on the top of the compressor.

The standard deliveries for the above models have suction and discharge flanges included. Service valves are supplied as an option.

Models RC1090B thru 1520B are recommended to be installed with 6" pipe on the discharge connection.

All Hanbell Rc2 models are supplied with an option for External discharge valves.

The Bitzer compressors are supplied as standard with service valves which are located on the top for the CSH6553-50 through the CSH8573-140. The suction valve connection is located on the end for the CSH9553-180 through the CSH9573-240. The connection sizes are also different and the size information supplied.

All BITZER CS compressors are supplied as standard with an internal discharge check valve which is located under the discharge service valve.

The weights of the compressors are similar and listed for comparison.

The control wiring for these compressors also has some differences.

The standard module included with the Hanbell RC series is the INT69. This module does not have phase protection.

Optional modules include the INT69Y and INT69HBY which have phase protection.

All three modules have power connected to L and N.

The INT69 has the control circuit connected to 11 and 14 where the optional modules have the control circuit wired thru M1 and M2.

The INT69 has the motor winding sensors and discharge gas temperature sensor wired in series to 1 and 2.

The optional modules have these wired via S1 and S2.

The Bitzer CSH and CSW series utilizes a SE-E1 electronic module as standard.

The SE-E1 is a dual voltage 110/220 volt with other voltages available.

The control circuit is wired through terminals 11 & 14 and module power is connected to L & N.

The oil temperature sensor and motor winding sensors (T-1 and T-2) are pre-wired to the module.

The SE-E1 provides phase protection and is connected to L1, 2 and 3.

There is an additional connection on the SE-E1 electronic module at terminal 12. This can be used to indicate a general compressor fault.



The SE-E1 is a dual voltage 115V / 230V or 24V AC module. The module will sense what voltage is being supplied.

- Each module is pre-wired inside the terminal box. The module monitors discharge gas / oil temperature via a PTC sensor. The module also monitors motor winding temperature via the motor sensors embedded into the motor windings which are wired in series and connected to the module. Phase sequence control for direction of rotation is also monitored.
- As mentioned above, each module is pre-wired inside the terminal box. The following connections should be checked for tightness.

Voltage / Phase Connections:

L-1 (black) connected to L-1 spade connection on the terminal plate.

L-2 (brown) connected to L-2 spade connection on the terminal plate.

L-3 (blue) connected to L-3 spade connection on the terminal plate.

Note: Each lead is identified at the plug connector with number markings and can also be found laser etched on the front of the module.

Motor Winding Temperature Connections:

T-1 (brown) connected to number 1 on the module.

T-2 (brown) connected to position 5 on the connector strip.

Discharge Gas / Oil Temperature Sensor PTC120:

The blue wire is connected to the opposite side of position 5 with the T-2 connection.

The brown wire connected to number 2 on the module.

- Compressor Control Circuit is wired through terminal 11 and 14.
- Terminal 12 can be utilized as a general compressor fault output. It will be powered whenever the module trips.

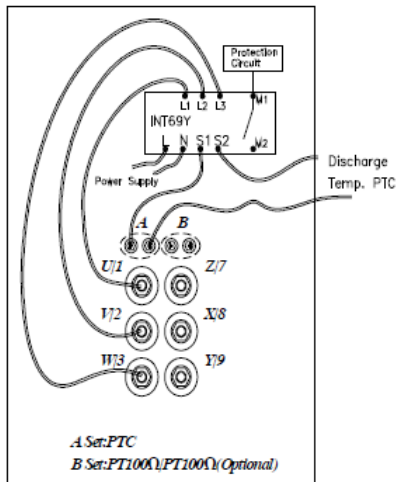

PT100 or PT1000 Connection

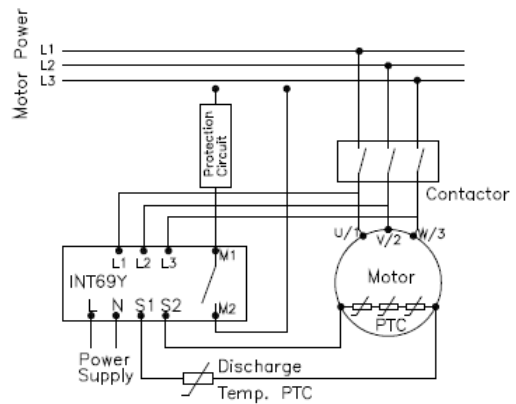

INT69Y Connection

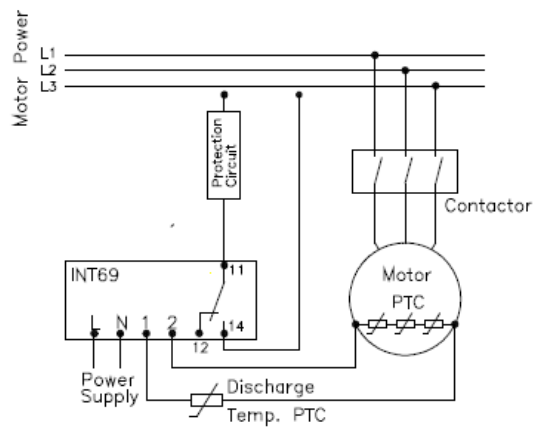
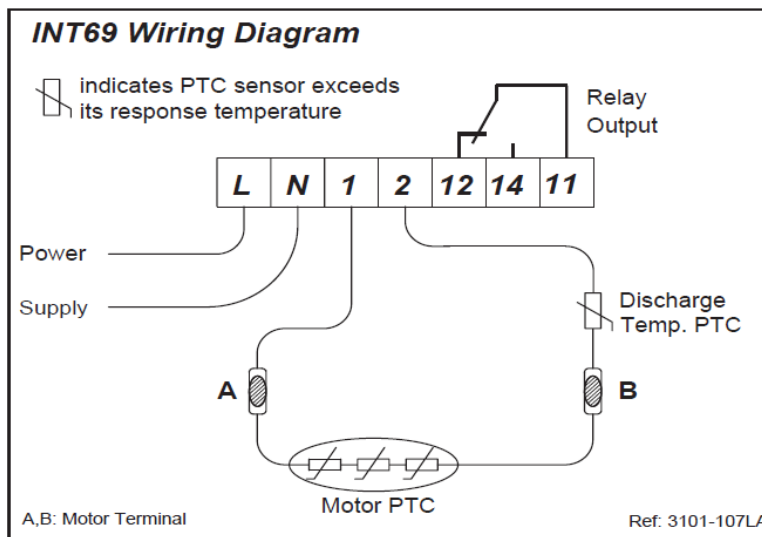

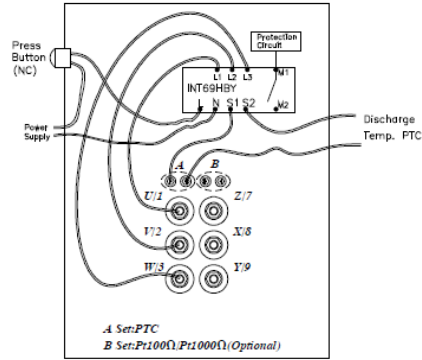
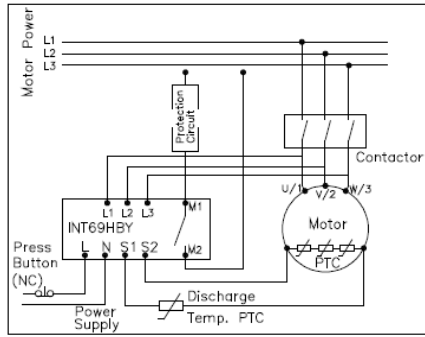

INT69HBY Motor Protector

Hanbell Optional Module: INT69HBY provides Phase Loss, Phase Sequence, Motor Temperature and Discharge Temperature Protection with Manual Reset

Typical Wiring Diagram for "XL" or "DOL" Starting Sequence

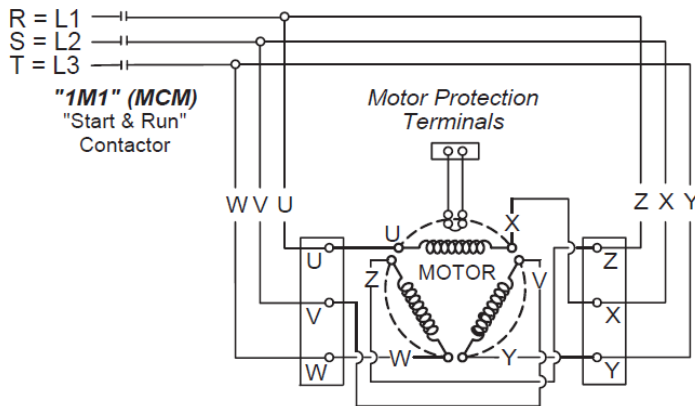

- "XL" (Across-the-Line) or "DOL" (Direct on Line) Starting Sequence
1. XL (DOL) Starting ~ 1M1 Closes and U, V, W plus Z, X, and Y are all energized simultaneously.
 2. XL (DOL) Starting Method is a single step starting, with a single contactor.
 3. The compressor terminals must be barred, "U-Z", "V-X", & "W-Y", for a three terminal wiring system as shown.

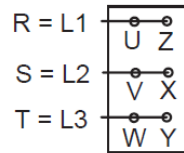

SRM-10713

There are two types of terminal cover plates used on the Hanbell RC2 series compressors (models RC2-100-930 A/B): one is with 6 power bolts and one set of sensor terminals (PTC) and the other is with 6 power bolts and 2 sets of sensor terminals (PTC & PT-100 or PT-1000). Hanbell will provide only one type of terminal cover which is the 6 power bolts and 2 sets of sensor terminals (PTC & PT-100 or PT-1000) from 2012.

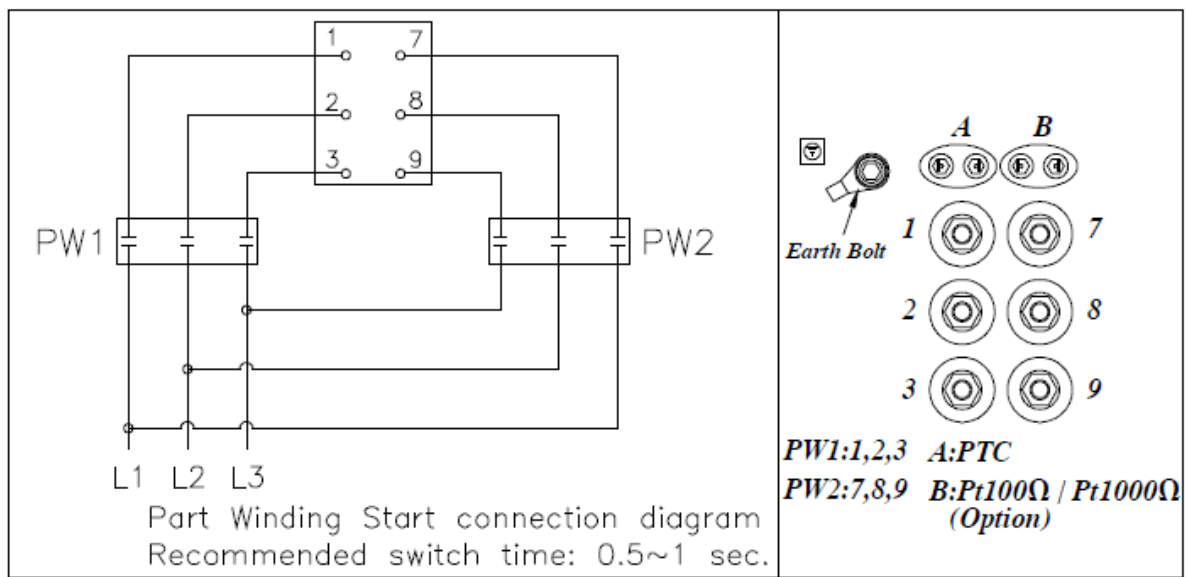
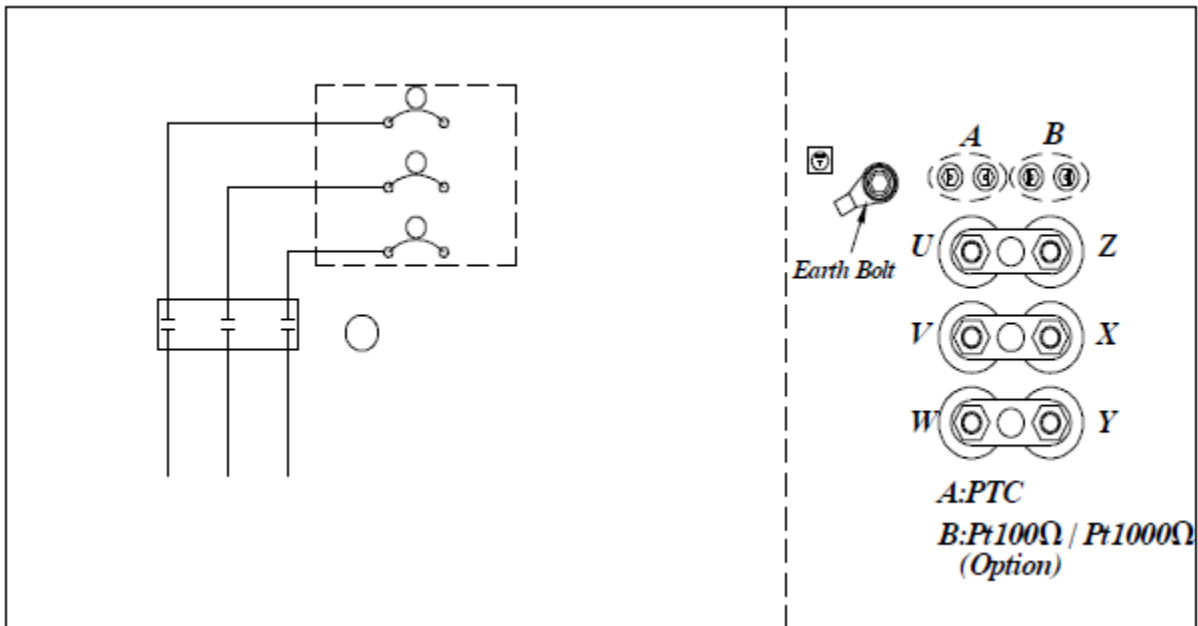

Capacity control differs between the two screw compressors.

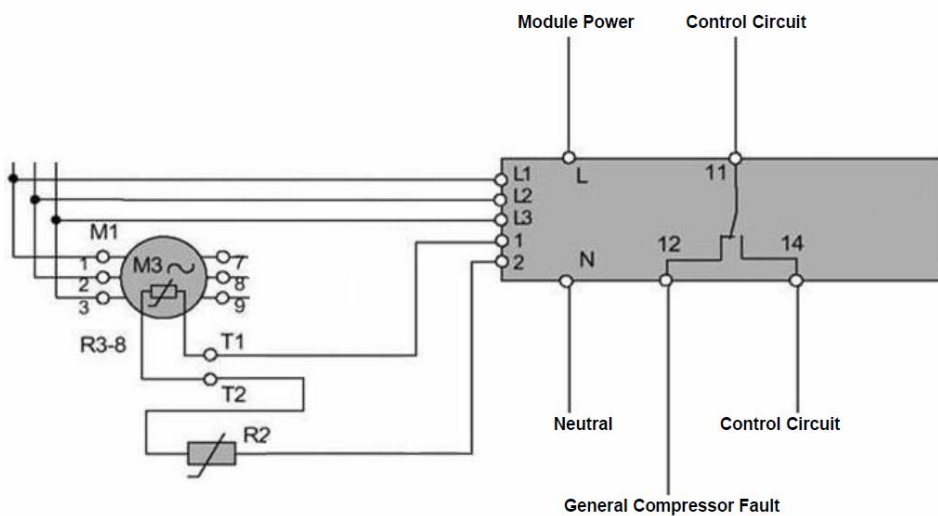
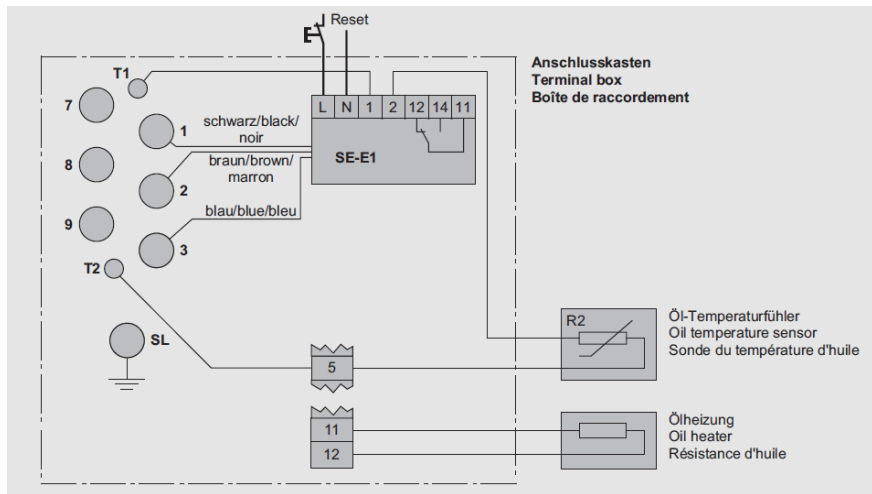

The loading and unloading of the compressors are also different. Depending on the Hanbell model with the type of capacity control provided, the control schemes will be different.

Charts are provided detailing the types of capacity control.

Depending on the model, capacity will range from a minimum of 25, 30 or 35% to 100%.

The Bitzer CS series of compressors can be applied in various configurations with No modification to the compressor required. Depending on the number of capacity solenoids used, the compressor can be applied as either 4 step capacity control (25, 50, 75 and 100% control), 25 to 100% Infinite capacity control where only 2 of the solenoids are used and even 3 Step capacity control where only 3 of the solenoids are used generally with a 50% minimum. By pulsing these solenoids back and forth, any part load condition can be achieved between 25% to 100% load.

3 Step Capacity Control		
RC2-100, 140, 180 Capacity Control System	SV33% (NC)	SV66% (NC)
100% of full load	de-energized	de-energized
66% of full load	de-energized	energized
33% (for starting)	energized	de-energized

4 Step Continuous Capacity Control			
RC2-170, RC2-200 to 1520 Capacity Control System	SV25% (NC)	SV75% (NC)	SV50% (NC)
100% full load	de-energized	de-energized	de-energized
75% of full load	de-energized	energized	de-energized
50% of full load	de-energized	de-energized	energized
25% (for starting)	energized	de-energized	de-energized

	Continuous Stepless Capacity Control		
	SV1 (NC) Standard	SV2 (NC) Standard	SV2 (NO) Option
Start	energized	de-energized	energized
Loading	de-energized	energized	de-energized
Unloading	energized	de-energized	energized
Stable	de-energized	de-energized	energized

Capacity control set-ups are dependent on type of capacity control options used with the compressor.

Load Solenoid

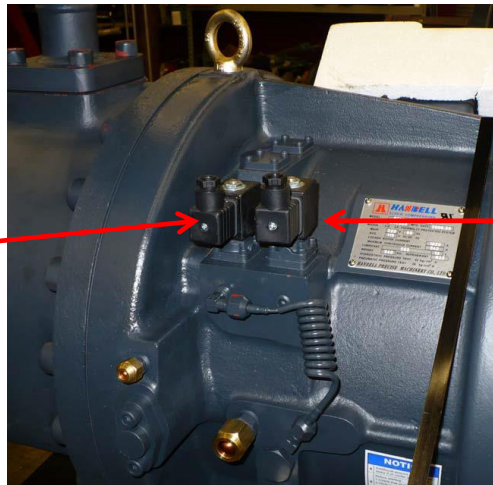

Unload Solenoid

Original Capacity Control 25-100%

75%

Load

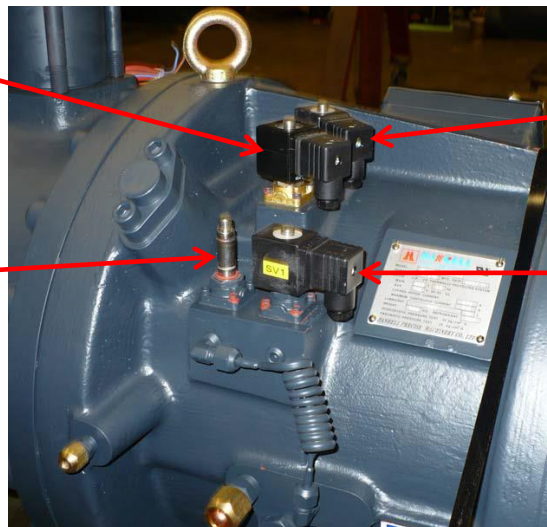

50%

25%

Standard Step Capacity Control (25, 50, 75, 100) (33, 66, 100)

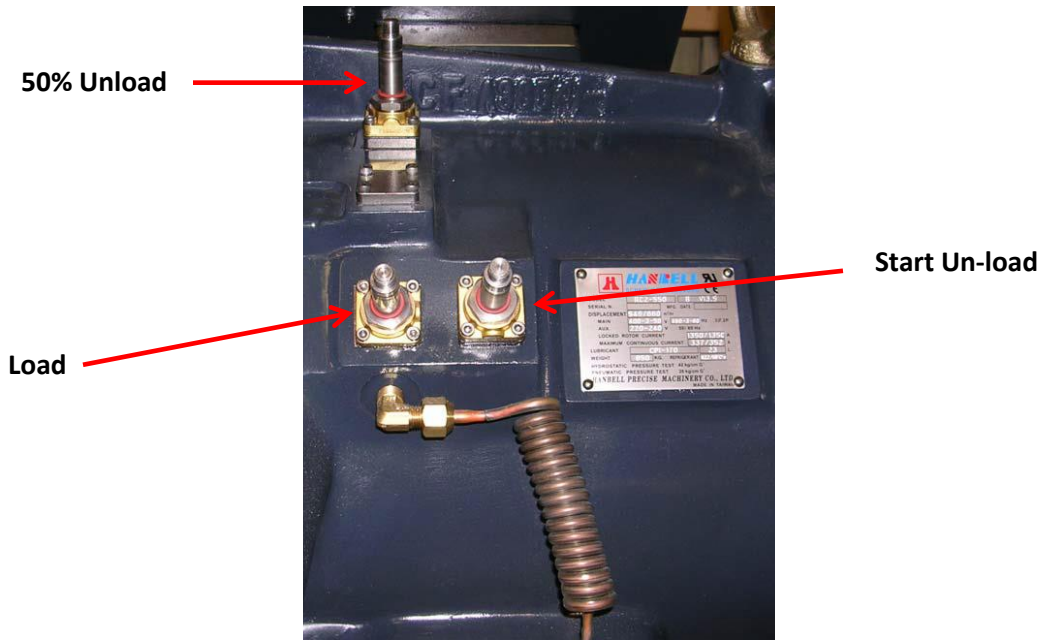

New Infinite Capacity Control 50-100%

When Hanbell screw compressors operate in part or full load within limits, there will be an increase in the motor coil and discharge temperatures.

In order to enable compressor to operate in succession safely, it is important to have the various kinds of auxiliary cooling devices properly installed which would require (1) Oil cooler (2) Liquid injection for chamber (3) Liquid injection for motor cooling.



For the Bitzer Screw Compressor-4-Step Capacity Control				
Operation	Solenoid 1	Solenoid 2	Solenoid 3	Solenoid 4
Start/stop	De-energized	De-energized	Energized	De-energized
Capacity 25%	De-energized	De-energized	Energized	De-energized
Capacity 50%	De-energized	Energized	De-energized	De-energized
Capacity 75%	Energized	De-energized	De-energized	De-energized
Capacity 100%	De-energized	De-energized	De-energized	Energized

For the Bitzer Screw Compressor-Infinite Capacity Control 25-100%		
Operation	Solenoid 3	Solenoid 4
Start/stop	Energized	De-energized
Loading	De-energized	Energized
Unloading	Energized	De-energized
Constant Load	Pulsing	Pulsing

Bitzer Screw Compressors Frame 2 Shown

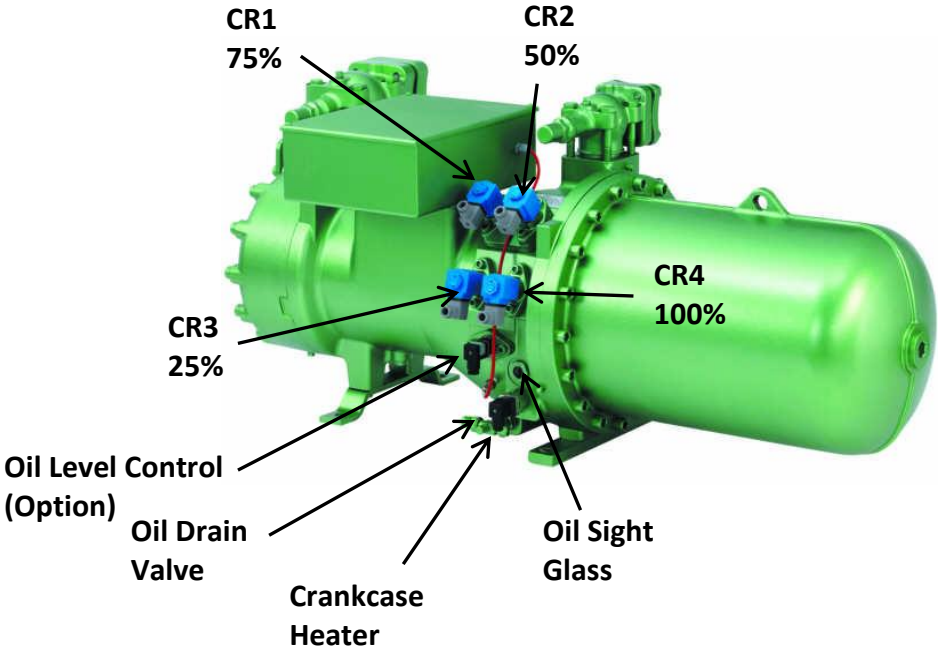

In applications where reduced voltage starting is used the Hanbell RC compressors can utilize Part Wind or Star Delta starting which is different than the Bitzer compressors which use part winding starting for the CSH6553-50 through the CSH8573-140. The CSH9553-180 through CSH9573-240 utilizes Star Delta reduced voltage starting. Full voltage or direct on line starting is the same for both compressors.

The overload relay, wiring size and the contactors must be checked for proper sizing on all replacements.

Piping and re-configuration will have to be completed when installing the BITZER CS compressor.

Hanbell Oil and Refrigerant Types		
Refrigerant Type	Standard Factory Oil	Alternate Lubricant
R22	Sun - Sunisco - 5GS	CPI CR4214-320 Mobil EAL100
R134A, R407C, R404A	CPI Solest 370	Mobil EAL100 ICI Emkarate RL421

BITZER Oil and Refrigerant Types	
Refrigerant Type	Standard Factory Oil
R22	CPI 4214-320
R134A, R407C, R404A, R507A	Solest 170

Connection Size			
Model Number	Suct	Disch	Weight
CSH6553-50	2-1/8"	1-5/8"	671
CSH6563-60	2-1/8"	1-5/8"	693
CSH7553-70	3-1/8"	2-1/8"	1058
CSH7563-80	3-1/8"	2-1/8"	1076
CSH7573-90	3-1/8"	2-1/8"	1091
CSH8553-110	4-1/8"	3-1/8"	1749
CSH8563-125	4-1/8"	3-1/8"	1762
CSH8573-140	4-1/8"	3-1/8"	1784
CSH9553-180	4-1/8"	3-1/8"	2734
CSH9563-210	4-1/8"	3-1/8"	2778
CSH9573-240	4-1/8"	3-1/8"	2800
CSH9583-280	5"	4-1/8"	3043
CSH9593-300	5"	4-1/8"	3087

Connection Size			
Model Number	Suct	Disch	Weight
CSW6583-50	2-5/8"	2-1/8"	805
CSW6593-60	2-5/8"	2-1/8"	805
CSW7573-70	3-1/8"	2-1/8"	1147
CSW7583-80	3-1/8"	2-1/8"	1169
CSW7593-90	3-1/8"	2-1/8"	1180
CSW8573-110	4-1/8"	3-1/8"	1874
CSW8583-125	4-1/8"	3-1/8"	1896
CSW8593-140	4-1/8"	3-1/8"	1918
CSW9563-160	4-1/8"	4-1/8"	2822
CSW9573-180	4-1/8"	4-1/8"	2844
CSW9583-210	5"	4-1/8"	2977
CSW9593-240	5"	4-1/8"	3043
CSW95103-280	5"	4-1/8"	3197

Connection Size			
Model Number	Suct	Disch	Weight
RC2-100B	1-5/8"	2-1/8"	617
RC2-140B	1-5/8"	2-1/8"	628
RC2-170B	1-5/8"	2-5/8"	838
RC2-180B	1-5/8"	2-5/8"	739
RC2-200B	1-5/8"	2-5/8"	937
RC2-230B	3-1/8"	2-1/8"	1224
RC2-260B	3-1/8"	2-1/8"	1235
RC2-300B	3-1/8"	2-1/8"	1323
RC2-310B	3-1/8"	2-1/8"	1279
RC2-320B	3-1/8"	2-1/8"	1323
RC2-340B	4-1/8"	2-5/8"	1367
RC2-370B	4-1/8"	2-5/8"	1411
RC2-410B	4-1/8"	2-5/8"	1631
RC2-470B	4-1/8"	2-5/8"	1786
RC2-510B	4-1/8"	3-1/8"	1720
RC2-550B	4-1/8"	3-1/8"	1874
RC2-580B	5"	3"	1852
RC2-610B	5"	3"	2116
RC2-620B	5"	3"	1940
RC2-710B	5"	4"	2423
RC2-790B	5"	4"	2601
RC2-830B	5"	4"	2679
RC2-930B	5"	4"	2734
RC2-1020B	5"	4"	3153
RC2-1090B	6"	5"	3483

Capacity Control %		
Model Number	Step	Stepless
RC2-100B	33,66,100	33-100
RC2-140B	33,66,100	33-100
RC2-170B	25,50,75,100	25-100
RC2-180B	33,66,100	33-100
RC2-200B	25,50,75,100	25-100
RC2-230B	35,50,75,100	35-100
RC2-260B	25,50,75,100	25-100
RC2-300B	25,50,75,100	25-100
RC2-310B	35,50,75,100	35-100
RC2-320B	25,50,75,100	25-100
RC2-340B	35,50,75,100	35-100
RC2-370B	35,50,75,100	35-100
RC2-410B	25,50,75,100	25-100
RC2-470B	25,50,75,100	25-100
RC2-510B	35,50,75,100	35-100
RC2-550B	25,50,75,100	25-100
RC2-580B	35,50,75,100	35-100
RC2-610B	25,50,75,100	25-100
RC2-620B	35,50,75,100	35-100
RC2-710B	35,50,75,100	35-100
RC2-790B	30,50,75,100	30-100
RC2-830B	30,50,75,100	30-100
RC2-930B	35,50,75,100	35-100
RC2-1020B	35,50,75,100	35-100
RC2-1090B	35,50,75,100	35-100

RC2-100~RC2-180 Outline

Note: Numbers in red indicate dimensions which RC2-B differs from RC2-A (A / B)

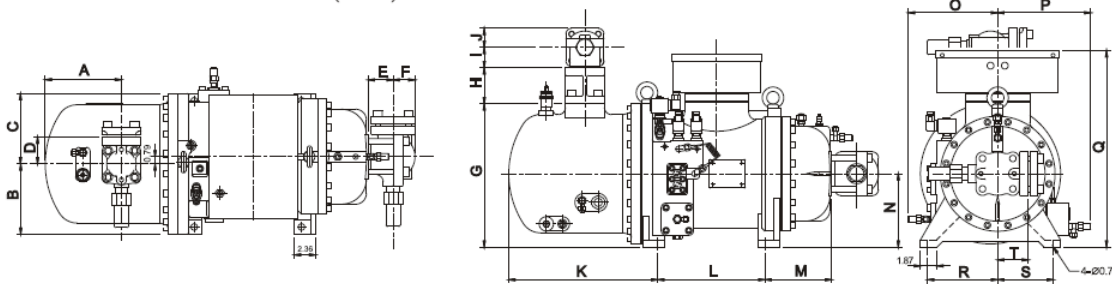

Model	Dimensions																			Unit: inch	
	A	B	C	D	E	F	G	H	I	J	K	L	M	N	O	P	Q	R	S	T	
RC2-100	8.39	7.72	7.72	2.95	2.76	2.40	15.75	3.98	2.22	2.09	16.4	11.81	7.34	8.07	9.80	10.24	21.59	7.72	6.14	3.39	
RC2-140	8.39	7.72	7.72	2.95	2.76	2.40	15.75	3.98	2.22	2.09	16.40	11.81	7.34	8.07	9.80	10.24	21.59	7.72	6.14	3.39	
RC2-180	11.14	7.72	7.72	2.95	3.19	2.70	16.14	3.98	2.22	2.09	19.15	15.20	7.72	8.07	9.45	10.24	21.59	7.72	6.14	3.74	

RC2-170~RC2-620 Outline

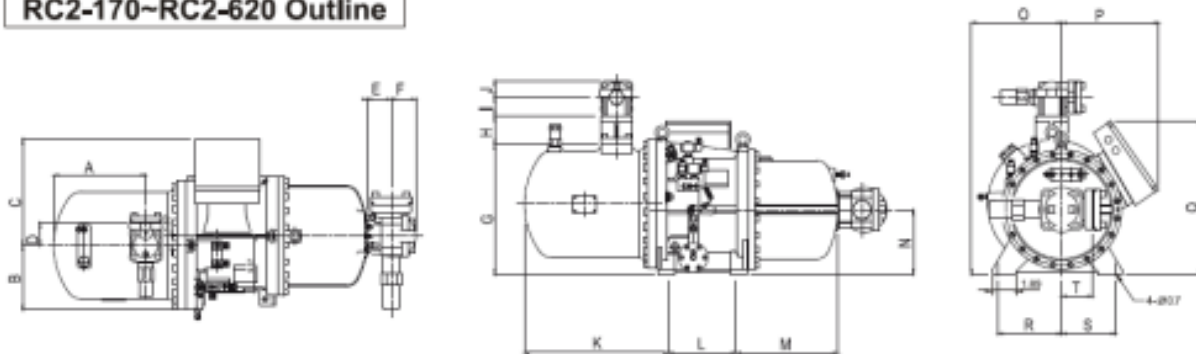

Model	Dimensions																			Unit: inch	
	A	B	C	D	E	F	G	H	I	J	K	L	M	N	O	P	Q	R	S	T	
RC2-170	12.20	9.02	14.88	2.95	3.23	2.72	17.60	3.98	2.24	2.09	19.72	7.87	13.43	8.86	9.65	14.25	23.31	8.86	8.86	3.74	
RC2-200	13.58	9.02	14.88	2.95	3.23	2.72	17.60	3.98	2.24	2.09	21.10	8.98	13.43	8.86	9.65	14.25	23.31	8.86	8.86	3.74	
RC2-230	14.37	9.84	15.94	3.39	3.82	3.35	19.76	4.17	2.64	2.40	22.32	9.88	15.71	10.12	11.38	15.39	24.57	9.45	9.45	4.21	
RC2-260	14.37	9.84	15.94	3.39	3.82	3.35	19.76	4.17	2.64	2.40	22.32	9.88	15.71	10.12	11.38	15.39	24.57	9.45	9.45	4.21	
RC2-300	16.06	9.84	15.94	3.39	3.82	3.35	19.76	4.17	2.64	2.40	24.02	11.22	13.35	10.12	11.38	15.39	24.57	9.45	9.45	4.21	
RC2-310	16.06	9.84	15.94	3.39	3.82	3.35	19.76	4.17	2.64	2.40	24.02	9.88	17.48	10.12	11.38	15.39	24.57	9.45	9.45	4.21	
RC2-320	16.06	9.84	15.94	3.39	3.82	3.35	19.76	4.17	2.64	2.40	24.02	11.22	13.35	10.12	11.38	15.39	24.57	9.45	9.45	4.21	
RC2-340	16.06	9.84	15.94	3.74	4.06	4.13	19.76	4.76	3.19	2.72	24.02	11.22	17.60	10.12	12.20	15.39	24.57	9.45	9.45	5.12	
RC2-370	16.06	9.84	15.94	3.74	4.06	4.13	19.76	4.76	3.19	2.72	24.02	11.22	17.60	10.12	12.20	15.39	24.57	9.45	9.45	5.12	
RC2-410	15.43	10.83	17.83	3.74	4.06	4.13	21.77	4.72	3.19	2.72	24.13	11.34	17.05	10.83	12.40	16.26	25.79	10.63	9.06	5.12	
RC2-470	17.32	10.83	17.83	3.74	4.06	4.13	21.77	4.72	3.19	2.72	26.02	12.60	17.05	10.83	12.40	16.26	25.79	10.63	9.06	5.12	
RC2-510	18.31	10.83	17.83	4.21	4.06	4.13	22.05	5.18	3.80	3.46	27.40	11.34	19.06	10.83	13.03	16.26	25.79	10.63	9.06	5.12	
RC2-550	19.06	10.83	17.78	4.21	4.06	4.13	22.52	5.18	3.80	3.46	28.35	12.60	18.78	11.02	13.03	16.20	25.94	10.63	9.06	5.12	
RC2-580	18.31	10.83	17.83	4.21	4.06	4.13	22.05	5.18	3.80	3.46	27.40	12.60	19.06	10.83	13.03	16.26	25.79	10.63	9.06	5.12	
RC2-620	19.06	10.83	17.78	4.21	8.66	4.88	22.52	5.18	3.80	3.46	28.35	12.60	20.67	11.02	13.03	16.20	25.94	10.63	9.06	6.34	

RC2-610~RC2-930 Outline

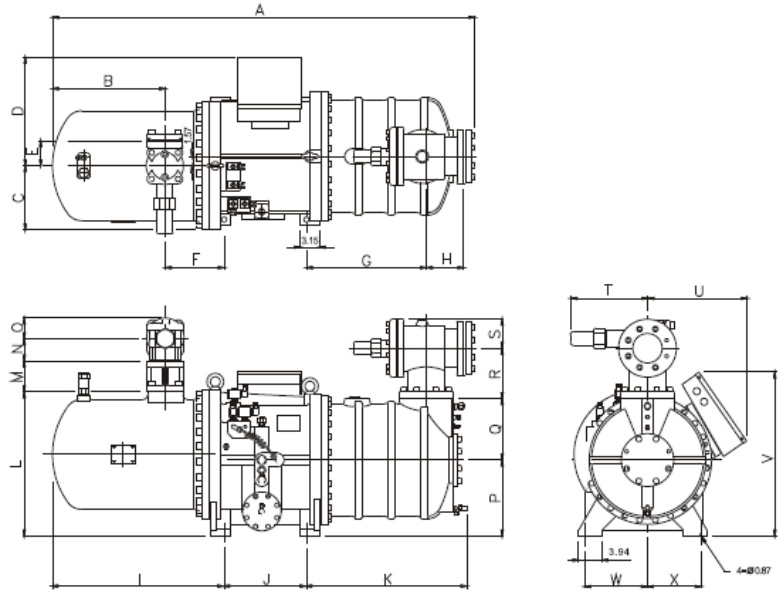

Model	Dimensions																				Unit: inch			
	A	B	C	D	E	F	G	H	I	J	K	L	M	N	O	P	Q	R	S	T	U	V	W	X
RC2-610	71.36	19.06	10.83	18.35	4.21	9.94	20.26	6.34	29.00	13.90	27.17	24.29	5.18	3.80	3.46	12.80	10.35	8.48	4.88	13.03	16.77	27.59	10.62	9.05
RC2-710	74.74	22.05	10.83	18.35	5.12	10.33	20.26	6.34	32.38	13.90	27.17 /29.92	24.29	5.18	4.06	4.13	12.80	10.35	8.48	4.88	13.78	16.77	27.59	10.62	9.05
RC2-790	77.30	22.05	10.83	18.35	5.12	10.33	20.26	6.34	32.38	16.46	27.17 /29.92	24.29	5.18	4.06	4.13	12.80	10.35	8.48	4.88	13.78	16.77	27.59	10.62	9.05
RC2-830	77.30	22.05	10.83	18.35	5.12	10.33	20.26	6.34	32.38	16.46	27.17 /29.92	24.29	5.18	4.06	4.13	12.80	10.35	8.48	4.88	13.78	16.77	27.59	10.62	9.05
RC2-930	80.06	22.05	10.83	18.35	5.12	10.33	23.01	6.34	32.38	16.46	29.92 /29.92	24.29	5.18	4.06	4.13	12.80	10.35	8.48	4.88	13.78	16.77	27.59	10.62	9.05

RC2-1090~RC2-1520 Outline

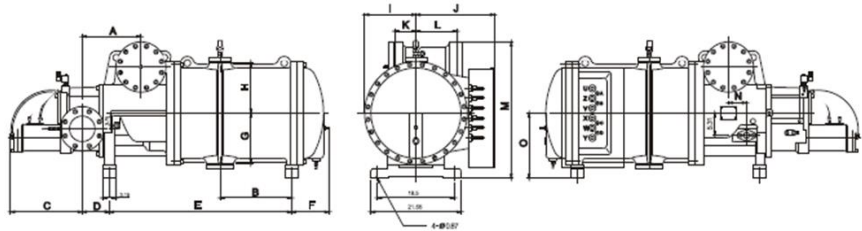

Model	Dimensions															Unit: inch	
	A	B	C	D	E	F	G	H	I	J	K	L	M	N	O		
RC2-1090	14.07	17.13	17.20	6.50	43.70	8.98	12.17	12.17	12.30	18.82	5.12	9.84	32.68	4.33	15.65		
RC2-1280	15.08	17.13	20.55	6.50	45.67 /43.50	8.98	12.17	12.17	12.30	18.82	5.20	10.43	34.35	5.24	15.65		
RC2-1520	15.08	17.13	20.55	6.50	45.67 /43.50	8.98	12.17	12.17	12.30	18.82	5.20	10.43	34.35	5.24	15.65		

CSH / CSW Screw Accessories

Crankcase Heater - Special Voltage Heater	
Part # (Voltage)	Model
343213-07 (230V)(200W)	(CS 65 - CS 75)
343213-02 (230V)(300W)	(CS 85 - CS 95)

Oil Level Control - Mechanical (CSH Series)	
Part #	Model
347403-05	(CSH 65)
347403-03	(CSH 75 - CSH 85)
347403-06	(CSH 95)

Oil Level Control - Electronic (CSH Series)	
Part #	Voltage
347962-02	115V
347962-01	230V
347962-03	24VAC

Liquid Injection Adapter Kit	
Part #	
361332-10	

Liquid Injection Controller	
Part #	
085-0164-17	

Economizer Adapter	
Model:	Part #
CS65	361329-16
CS75	361329-16
CS85	361330-05
CS95	361330-07

Pressure Controller with 1/4" NPT Transducer Sensor	
Kit Part #	
999-0005-01	

Temperature - Strap On Sensor with Capacity Controller	
Kit Part #	
999-0003-01	

Temperature - 1/4" NPT Insert Sensor with Capacity Controller	
Kit Part #	
999-0004-01	

BITZER Oils for CS Series		
Model	Refrigerant	Oil
CSH	R22	B320SH
	R134a/R407C/R404A/R507A	BSE170
CSW	R22	B320SH
	R134a	BSE170L

B320SH Polyolester Oil	
Unit of Measurement	Part #
1 gallon	793-3320-01
5 gallon	793-3320-34

BSE 170 Polyolester Oil	
Unit of Measurement	Part #
1 gallon	793-1170-34
5 gallon	793-3170-34

BSE 170 L Polyolester Oil	
Unit of Measurement	Part #
1 liter	915118-06
5 liter	915118-01
10 liter	915118-02

BITZER CSH Screw Compressor Dimensional Data

CSH65

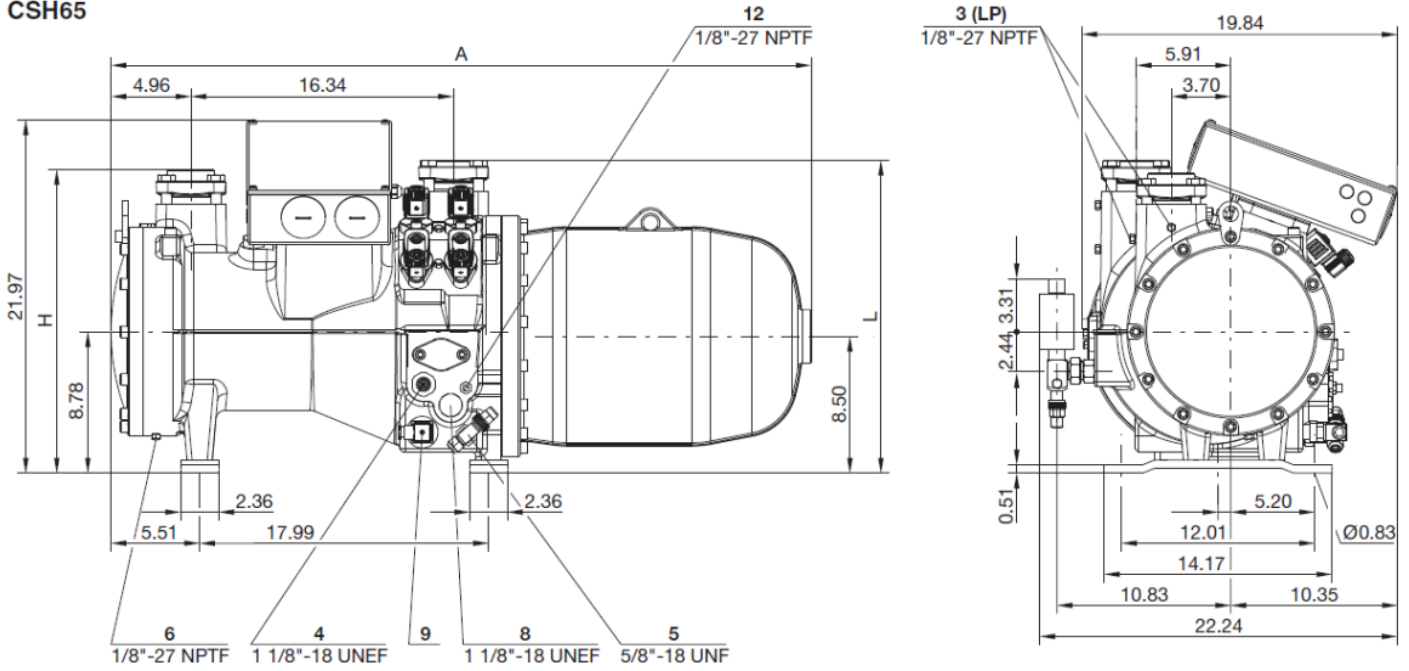

CSH75

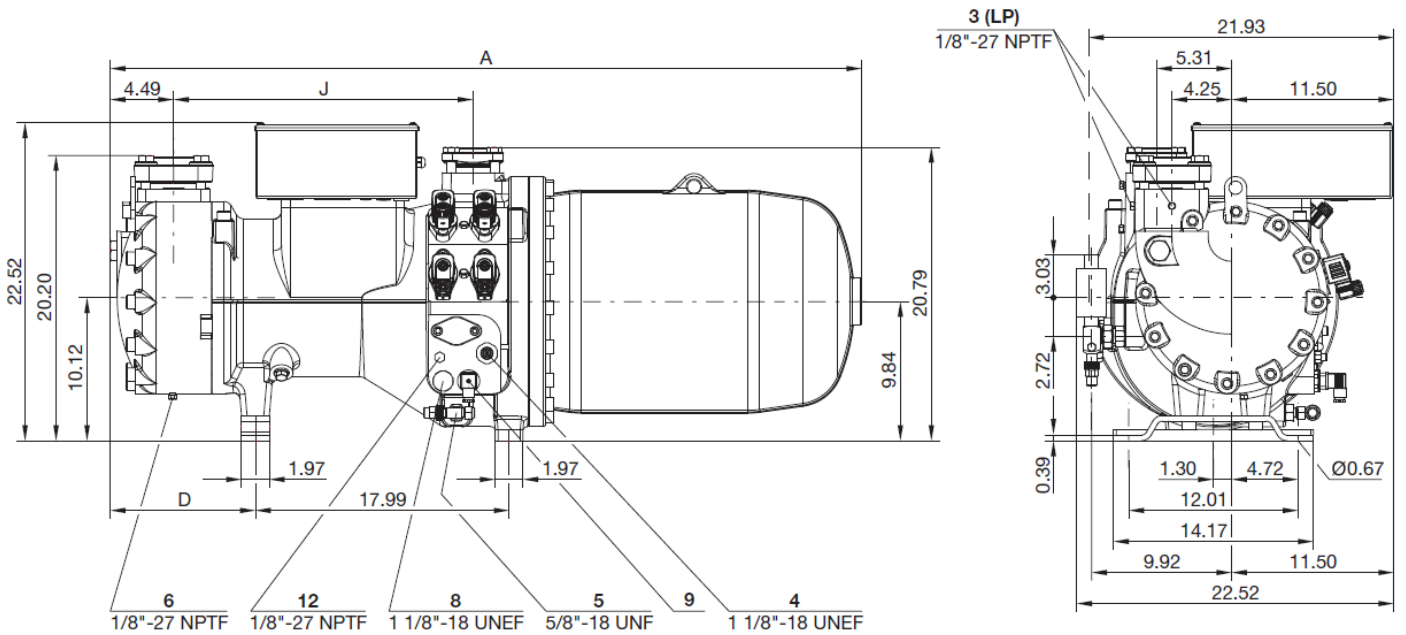

CSH85

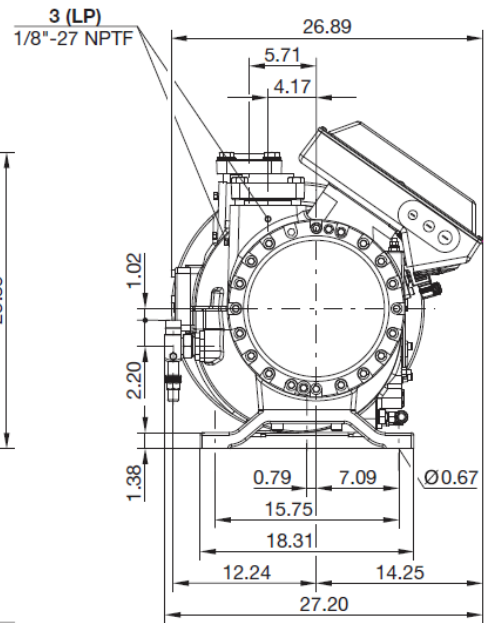
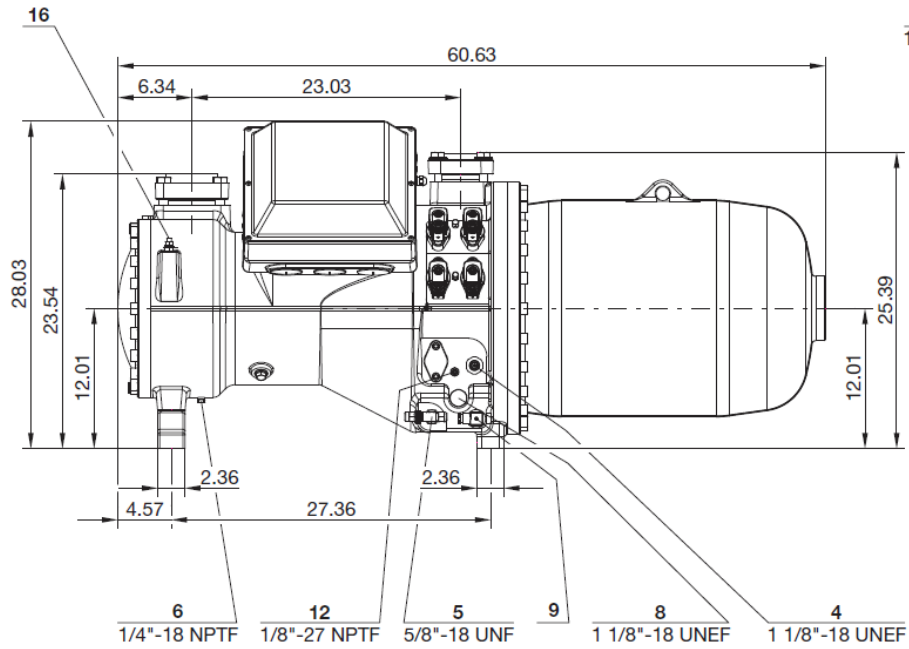

CSH95

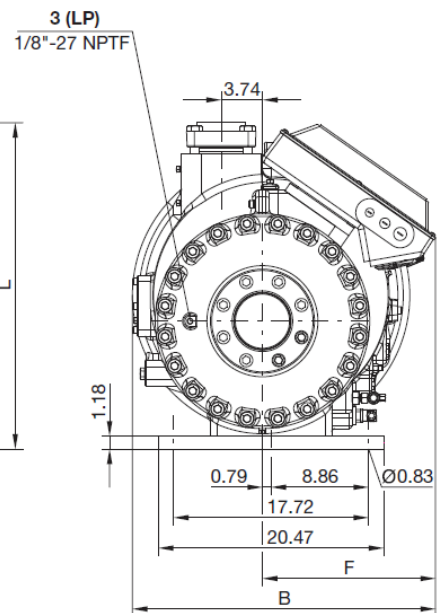
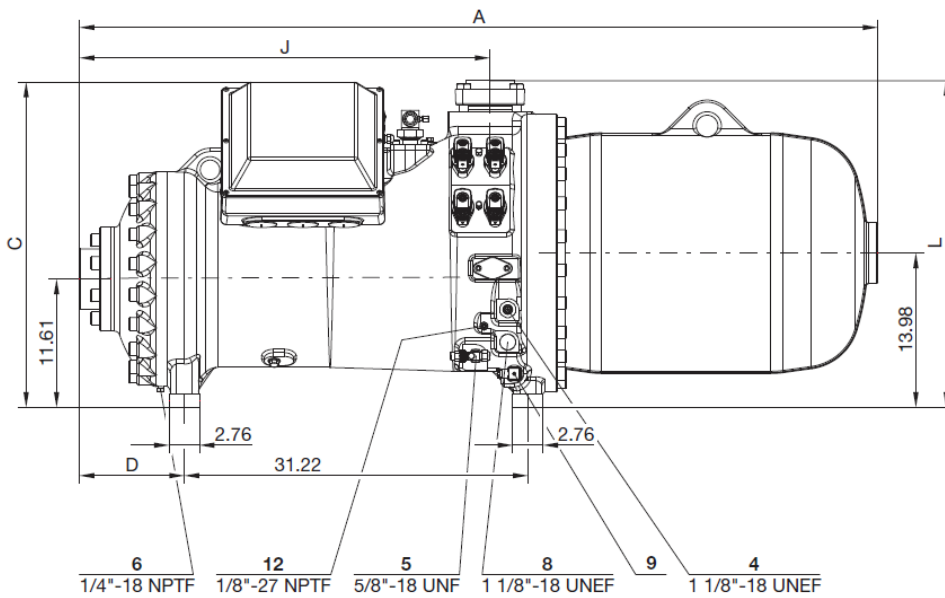



NOTES

Please Note:

The advice given herein and/or any conclusions made by BITZER US, Inc. represent BITZER US, Inc.'s best advice and judgment under the circumstances, but such advice and/or conclusions made or results obtained shall be deemed used at your sole risk. For further assistance, please contact our application engineering department using the contact information on the back page of this booklet.



BITZER Competitive Replacement Inquiry

Date: _____

Name	
Company Name	
Address	
City, State, Zip	
Phone	
Cell Phone	
Email	
Customer's Name	
Address	

Brand of the compressor you are replacing: _____

Compressor Model No.: _____ Serial No.: _____

System Manufacturer (OEM) and Unit Model #: _____

Please specify single circuit or compressor is in parallel: _____

Type of refrigerant used: _____ Tonnage requirement: _____

Operating condition: Evaporating: _____

 Condensing: _____

 Suction superheat: _____

 Subcooling: _____

 Voltage: _____

Reason for replacement: _____

How many compressors are you looking to replace?: _____

Please provide any additional comments: _____
