



# COPELAND™ TO BITZER CONVERSION GUIDE

## RECIPROCATING COMPRESSORS

FOR MODELS

3D › CE4 / 4D › BE5 / 6D › BE6

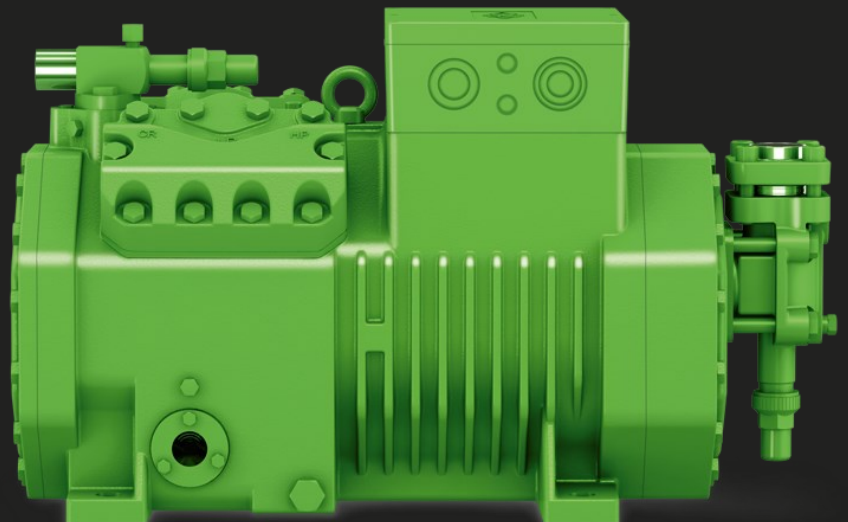
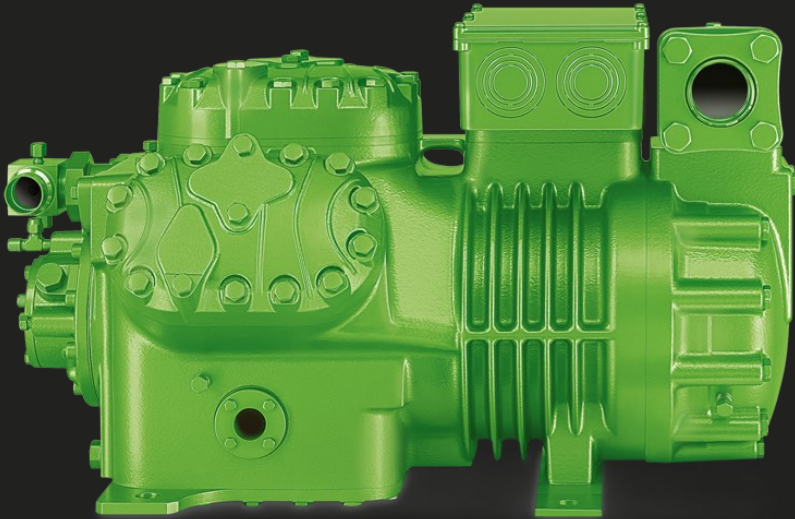



The intention of this document is to serve as general guidelines. The information contained is not intended to replace specific equipment and/or system manufacturer's information or guidelines. BITZER implies no liability for the information contained. It is BITZER's implicit intention that nothing contained in this guide replaces any past, present or future warranty policy of BITZER and/or any other manufacturer's equipment

These guidelines are not a replacement for information specific to that of the manufacturer or the manufacturer's system technical product information.

Each system may vary in design, usage and specifications. This document is intended for use specific to the compressor only and not intended to be a "catch all" for any and every possible application of the compressor.

BITZER's intention is that only qualified and certified (where applicable) individuals specific to the refrigeration industry use the information contained and all standard refrigeration handling and safety practices must be followed at all times.

BITZER's intention is that all electric work is performed by qualified and certified (where applicable) individuals and all standard electrical safety practices must be followed at all times.

**WARNING**

This icon indicates instructions to avoid personal injury and material damage



**CAUTION**

This icon indicates instructions to avoid property damage and possible personal injury



**HIGH VOLTAGE**

This icon indicates operations with a danger of electric shock



To the best of our knowledge, the information in this book is accurate. However, BITZER US, BITZER CANADA, and BITZER MEXICO do not assume any liability for the accuracy or completeness of any contents. No warranty information can be applied to or inferred from the use of this book.

\*Copeland™ is a registered trademark of the Emerson Electric Company

# TABLE OF CONTENTS

<b>1. PROPER SELECTION OF COMPRESSOR, PARTS, AND KITS</b>	<b>4-11</b>
1.1 CROSS REFERENCE CHARTS AND CONVERSION KIT	4-8
1.2 SUMMARY OF STANDARD OPTIONS AND ACCESSORIES	9
1.3 SUMMARY OF LOW TEMP R22 & R407A/F ACCESSORIES	10
<b>2. INSTALLATION INSTRUCTIONS: REPLACING COPELAND 3D WITH BITZER CE4</b>	<b>11-21</b>
2.1 ADAPTER KIT PARTS LIST	11-12
2.2 REMOVING COPELAND 3D COMPRESSOR	13
2.3 INSTALLING THE BITZER CE4 COMPRESSOR	14-18
2.4 INSTALLING THE BITZER OIL MONITORING SYSTEM (“S” MODELS)	19
2.5 MECHANICAL OR ELECTRONIC OIL PROTECTION	20
2.6 INSTALLING HEAD COOLING FANS	21
<b>3. INSTALLATION INSTRUCTIONS: REPLACING COPELAND 4D WITH BITZER BE5</b>	<b>22-30</b>
3.1 ADAPTER KIT PARTS LIST	22-23
3.2 REMOVING COPELAND 4D COMPRESSOR	24
3.3 INSTALLING THE BITZER BE5 COMPRESSOR	25-28
3.4 MECHANICAL OR ELECTRONIC OIL PROTECTION	29
3.5 INSTALLING HEAD COOLING FANS	30
<b>4. INSTALLATION INSTRUCTIONS: REPLACING COPELAND 6D WITH BITZER BE6</b>	<b>31-40</b>
4.1 ADAPTER KIT PARTS LIST	31-32
4.2 REMOVING COPELAND 6D COMPRESSOR	33
4.3 INSTALLING THE BITZER BE6 COMPRESSOR	34-38
4.4 MECHANICAL OR ELECTRONIC OIL PROTECTION	39
4.5 INSTALLING HEAD COOLING FANS	40
<b>5. DIMENSIONS AND PORT LOCATIONS</b>	<b>42-43</b>
<b>6. R22 &amp; R407A/F LOW TEMP APPLICATION</b>	<b>44-48</b>
6.1 USING CIC OR A TEMPERATURE RESPONSIVE EXPANSION VALVE (Y1037)	45
6.2 INSTALLING A DISCHARGE TEMPERATURE SENSOR	46
6.3 RE-USING DEMAND COOLING COMPONENTS WITH BITZER COMPRESSOR	47-48
<b>7. COMPARING OLD AND NEW BITZER AND COPELAND NOMENCLATURE</b>	<b>49</b>
<b>8. BITZER TERMINAL BOX WIRING DIAGRAM</b>	<b>50</b>
<b>9. APPENDIX</b>	<b>51-54</b>
A. Wiring	51-53
B. Installing the Terminal Box Plate Adapter (p/n 999-0024-01)	54
C. Installing the Pressure Switch Plate (p/n 999-0026-01)	55
D. Installing the Resistor Pack (p/n 999-0028-01)	56
<b>10. TROUBLESHOOTING</b>	<b>57-58</b>
<b>11. START UP DATA SHEET</b>	<b>59</b>

# 1.1 Cross Reference



Copeland Model #	Old Copeland Model #	CFH	ECOLINE BITZER Model #	CFH	Kit #
<b>3D MODELS</b>					
3DA♦F18K	3DA♦♦050	1370	4VE-7-000	1479	542010-00KIT
3DA♦F28K	3DA♦♦060	1370	4VE-7-000	1479	542010-00KIT
3DA♦R10M	3DA♦♦075	1370	4VE-10-000	1479	542010-00KIT
3DB♦F22K	3DB♦♦050	1615	4TE-9-000	1760	542010-00KIT
3DB♦F33K	3DB♦♦075	1615	4TE-9-000	1760	542010-00KIT
3DB♦F27K	3DB♦♦090	1615	4TE-9-000	1760	542010-00KIT
3DB♦R12M	3DB♦♦100	1615	4TE-12-000	1760	542010-00KIT
3DE♦F18K	3DE♦♦050	1370	4VE-7-000-1D	1479	542010-00KIT
3DE♦R10M	3DE♦♦075	1370	4VE-10-000-1D	1479	542010-00KIT
3DF♦F26K	3DF♦♦075	1913	4PE-12-000	2067	542010-00KIT
3DF♦F40K	3DF♦♦090	1913	4PE-12-000	2067	542010-00KIT
3DF♦R15M	3DF♦♦120	1913	4PE-15-000	2067	542010-01KIT
3DG♦F40K	3DG♦♦090	1913	4PE-12-000-1D	2067	542010-00KIT
3DH♦F28K	3DH♦♦060	1370	4VE-7-000-1D	1479	542010-00KIT
3DJ♦F33K	3DJ♦♦075	1615	4TE-9-000-1D	1760	542010-00KIT
3DJ♦F27K	3DJ♦♦090	1615	4TE-9-000-1D	1760	542010-00KIT
3DK♦F26K	3DK♦♦075	1913	4PE-12-000-1D	2067	542010-00KIT
3DK♦F40K	3DK♦♦090	1913	4PE-12-000-1D	2067	542010-00KIT
3DK♦R15M	3DK♦♦120	1913	4PE-15-000-1D	2067	542010-01KIT
3DP♦F33K	3DP♦♦075	1615	4TE-9-000-1D	1760	542010-00KIT
3DP♦F27K	3DP♦♦090	1615	4TE-9-000-1D	1760	542010-00KIT
3DP♦R12M	3DP♦♦100	1615	4TE-12-000-1D	1760	542010-00KIT
3DR♦F46K	3DR♦♦100	2127	4NE-14-000-1D	2395	542010-00KIT
3DS♦F30K	3DS♦♦075	2127	4NE-14-000	2395	542010-00KIT
3DS♦F46K	3DS♦♦100	2127	4NE-14-000	2395	542010-00KIT
3DS♦R11M	3DS♦♦100	2127	4NE-14-000	2395	542010-00KIT
3DS♦R17M	3DS♦♦150	2129	4NE-20-000	2395	542010-02KIT
3DS♦S12M		2127	4NE-20-000	2395	542010-02KIT
3DT♦F30K	3DT♦♦075	2127	4NE-14-000-1D	2395	542010-00KIT
3DT♦R11M	3DT♦♦100	2127	4NE-14-000-1D	2395	542010-00KIT
3DT♦R17M	3DT♦♦150	2129	4NE-20-000-1D	2395	542010-02KIT
<b>4D MODELS</b>					
4DA♦F47K	4DA♦♦101	2386	4JE-15-000	2707	542010-07KIT
4DA♦R12M	4DA♦♦100	2386	4JE-15-000	2707	542010-07KIT
4DA♦R18M	4DA♦♦200	2386	4JE-22-000	2707	542010-07KIT
4DA♦S13M		2386	4JE-15-000	2707	542010-00KIT
4DB♦F54K		2760	4JE-15-000	2707	542010-07KIT
4DB♦R20M	4DB♦♦220	2760	4JE-22-000†	2707	542010-07KIT
4DC♦F54K		2760	4JE-15-000-1D	2707	542010-07KIT
4DC♦R20M	4DC♦♦220	2760	4JE-22-000-1D†	2707	542010-07KIT
4DE♦R12M	4DE♦♦100	2386	4JE-15-000-1D	2707	542010-07KIT
4DE♦F47K	4DE♦♦101	2386	4JE-15-000-1D	2707	542010-07KIT
4DE♦R18M	4DE♦♦200	2386	4JE-22-000-1D	2707	542010-07KIT
4DH♦R16M	4DH♦♦150	3016	4HE-18-000	3141	542010-07KIT
4DH♦S16M		3016	4HE-18-000	3141	542010-07KIT
4DH♦F63K	4DL♦♦150	3016	4HE-18-000	3141	542010-07KIT
4DH♦R22M	4DH♦♦250	3016	4HE-25-000	3141	542010-07KIT
4DJ♦R19M	4DJ♦♦200	3603	4GE-23-000	3606	542010-07KIT
4DJ♦F76K	4DT♦♦220	3603	4GE-23-000	3606	542010-07KIT
4DJ♦R28M	4DJ♦♦270	3603	4GE-30-000	3606	542010-07KIT
4DJ♦R28M	4DJ♦♦300	3603	4GE-30-000	3606	542010-07KIT
4DK♦F63K	4DP♦♦150	3016	4HE-18-000-1D	3141	542010-07KIT
4DK♦R16M	4DK♦♦150	3016	4HE-18-000-1D	3141	542010-07KIT
4DK♦S16M		3016	4HE-18-000-1D	3141	542010-07KIT
4DK♦R22M	4DK♦♦250	3016	4HE-25-000-1D	3141	542010-07KIT
4DL♦F63K	4DL♦♦150	3016	4HE-18-000	3141	542010-07KIT
4DN♦R12M	4DN♦♦100	2386	4JE-15-000-1D	2707	542010-07KIT
4DN♦F47K	4DN♦♦101	2386	4JE-15-000-1D	2707	542010-07KIT
4DP♦F63K	4DP♦♦150	3016	4HE-18-000-1D	3141	542010-07KIT
4DR♦R19M	4DR♦♦200	3603	4GE-23-000-1D	3606	542010-07KIT
4DR♦F76K	4DS♦♦220	3603	4GE-23-000-1D	3606	542010-07KIT
4DR♦R28M	4DR♦♦300	3603	4GE-30-000-1D	3606	542010-07KIT
4DS♦F76K	4DS♦♦220	3603	4GE-23-000-1D	3606	542010-07KIT
4DT♦F76K	4DT♦♦220	3603	4GE-23-000	3606	542010-07KIT

† Order Special endbell / suction valve kit: 305218-01-KIT (no charge separate line item)



## 1.1 Cross Reference

Copeland Model #	Old Copeland Model #	CFH	ECOLINE BITZER Model #	CFH	Kit #
<b>6D MODELS</b>					
6DB♦R32M	6DB♦♦300	4140	6JE-33-◇◇◇	4062	542010-08KIT
6DC♦F93K	6DC♦♦270	4524	6HE-28-◇◇◇-1D	4710	542010-08KIT
6DD♦F93K	6DD♦♦270	4524	6HE-28-◇◇◇-2D	4710	542010-08KIT
6DE♦F11M	6DE♦♦300	5405	6GE-34-◇◇◇-1D	5404	542010-08KIT
6DF♦F11M	6DF♦♦300	5405	6GE-34-◇◇◇-2D	5404	542010-08KIT
6DG♦R37M	6DG♦♦350	4955	6GE-40-◇◇◇	5404	542010-08KIT
6DH♦F93K	6DL♦♦270	4524	6HE-28-◇◇◇	4710	542010-08KIT
6DH♦R23M	6DH♦♦200	4524	6HE-28-◇◇◇	4710	542010-08KIT
6DH♦R35M	6DH♦♦350	4524	6HE-35-◇◇◇	4710	542010-08KIT
6DJ♦F11M	6DT♦♦300	5405	6GE-34-◇◇◇	5404	542010-08KIT
6DJ♦R28M	6DJ♦♦300	5405	6GE-34-◇◇◇	5404	542010-08KIT
6DJ♦R40M	6DJ♦♦400	5405	6GE-40-◇◇◇	5404	542010-08KIT
6DK♦F93K	6DC♦♦270	4524	6HE-28-◇◇◇-1D	4710	542010-08KIT
6DK♦R23M	6DK♦♦200	4524	6HE-28-◇◇◇-1D	4710	542010-08KIT
6DK♦R35M	6DK♦♦350	4524	6HE-35-◇◇◇-2D	4710	542010-08KIT
6DL♦F93K	6DL♦♦270	4524	6HE-28-◇◇◇	4710	542010-08KIT
6DM♦R37M	6DM♦♦350	4955	6HE-35-◇◇◇-1D	4710	542010-08KIT
6DN♦R37M	6DN♦♦350	4955	6HE-35-◇◇◇-2D	4710	542010-08KIT
6DP♦F93K	6DD♦♦270	4524	6HE-35-◇◇◇-2D	4710	542010-08KIT
6DP♦R23M	6DP♦♦200	4524	6HE-28-◇◇◇-1D	4710	542010-08KIT
6DP♦R35M	6DP♦♦350	4524	6HE-35-◇◇◇-2D	4710	542010-08KIT
6DR♦F11M	6DE♦♦300	5405	6GE-34-◇◇◇-1D	5404	542010-08KIT
6DR♦R28M	6DR♦♦300	5405	6GE-34-◇◇◇-1D	5404	542010-08KIT
6DR♦R40M	6DR♦♦400	5405	6GE-40-◇◇◇-2D	5404	542010-08KIT
6DS♦F11M	6DS♦♦300	5405	6GE-40-◇◇◇-2D	5404	542010-08KIT
6DS♦R28M	6DS♦♦300	5405	6GE-34-◇◇◇-1D	5404	542010-08KIT
6DS♦R40M	6DS♦♦400	5405	6GE-40-◇◇◇-2D	5404	542010-08KIT
6DT♦F11M	6DT♦♦300	5405	6GE-34-◇◇◇	5404	542010-08KIT
6DU♦F13M		6527	6FE-44-◇◇◇	6461	542010-08KIT
6DU♦R49M		6527	6FE-44-◇◇◇	6461	542010-08KIT
6DV♦F13M		6527	6FE-44-◇◇◇-1D	6461	542010-08KIT
6DV♦R49M		6527	6FE-44-◇◇◇-1D	6461	542010-08KIT
6DW♦R32M	6DW♦♦300	4140	6JE-33-◇◇◇-1D	4062	542010-08KIT
6DY♦R32M	6DY♦♦300	4140	6JE-33-◇◇◇-2D	4062	542010-08KIT
<b>8D - SERIES</b>					
8DP1R56M	8DP♦♦500	6429	6FE-50-◇◇◇	6461	N/A
8DS1R67M	8DS♦♦600	7609	8GE-60-◇◇◇	7885	N/A

**PLEASE REVIEW ALL X-REF'S FOR DISPLACMENT, HIGH/LOW TEMP APPLICATION AND UNLOADERS**

♦ = Blank, hyphen, letter, number or space.

◇◇◇ = "2NU" for 230V or 460V (Copeland motor code = TSK, TSC, TSN, TAC, TAD, TFC, TFD)

◇◇◇ = "5PU" for 575V (Copeland motor code = TAE, TFE, TSE)

All compressors ship dry (except two stage compressors - include Y for POE oil, blank for AB oil)

1D will have one unloader

2D will have two unloaders

# 1.1 Cross Reference



Copeland Model #	Old Copeland Model #	CFH	ECOLINE BITZER Model #	CFH	Kit #
<b>4R MODELS</b>					
	4RA♦♦100	2380	4JE-15-♦♦♦	2707	542010-07KIT
	4RA♦♦200	2380	4JE-22-♦♦♦	2707	542010-07KIT
	4RE♦♦100	2380	4JE-22-♦♦♦-1D	2707	542010-07KIT
	4RE♦♦200	2380	4JE-22-♦♦♦-1D	2707	542010-07KIT
	4RH♦♦150	3020	4HE-18-♦♦♦	3141	542010-07KIT
	4RH♦♦250	3020	4HE-25-♦♦♦	3141	542010-07KIT
4RJ2♦200*	4RJ1♦200	3603	4GE-23-♦♦♦	3606	542010-07KIT
4RJ2♦300*	4RJ1♦300	3603	4GE-30-♦♦♦	3606	542010-07KIT
	4RK♦♦150	3020	4HE-18-♦♦♦-1D	3141	542010-07KIT
	4RK♦♦250	3020	4HE-25-♦♦♦-1D	3141	542010-07KIT
	4RL♦♦150	3020	4HE-18-♦♦♦	3141	542010-07KIT
	4RL♦♦190	3020	4HE-18-♦♦♦	3141	542010-07KIT
4RR2♦300*	4RR1♦300	3605	4GE-30-♦♦♦-1D	3606	542010-07KIT
<b>6R MODELS</b>					
	6RA♦♦100	3580	4GE-23-♦♦♦	3606	N/A
	6RA♦♦200	3580	6JE-25-♦♦♦	4062	542010-08KIT
	6RA♦♦300	3580	6JE-33-♦♦♦	4062	N/A
	6RB♦♦100	3580	NA	4061	N/A
	6RB♦♦200	3580	NA	4061	N/A
	6RE♦♦200	3580	6JE-25-♦♦♦-2D	4062	542010-08KIT
	6RE♦♦300	3580	6JE-33-♦♦♦-2D	4062	542010-08KIT
	6RH♦♦200	4530	6HE-28-♦♦♦	4710	542010-08KIT
	6RH♦♦350	4530	6HE-35-♦♦♦	4710	542010-08KIT
	6RJ♦♦400	5405	6GE-40-♦♦♦	5404	542010-08KIT
	6RK♦♦250	4530	6HE-28-♦♦♦-2D	4710	542010-08KIT
	6RK♦♦350	4530	6HE-35-♦♦♦-2D	4710	542010-08KIT
	6RL♦♦250	4530	6HE-28-♦♦♦	4710	542010-08KIT
	6RN♦♦200	3580	6JE-25-♦♦♦-2D	4062	542010-08KIT
	6RN♦♦300	3580	6JE-25-♦♦♦-2D	4062	542010-08KIT
	6RP♦♦200	4530	6HE-28-♦♦♦-2D	4710	542010-08KIT
	6RP♦♦350	4530	6HE-35-♦♦♦-2D	4710	542010-08KIT
	6RR♦♦400	5408	6GE-40-♦♦♦-2D	5404	542010-08KIT
	6RS♦♦400	5404	6GE-40-♦♦♦-2D	5404	542010-08KIT
	6RT♦♦300	5404	6GE-34-♦♦♦	5404	542010-08KIT
	6TM♦♦200	4530	S6F-30.2	4309	N/A

\* Requires feet spacers hardware 930-1944-04 (4), 900-4107-44 (4), 901-0107-00 (4), and 903-0107-08 (4)

♦ = Blank, hyphen, letter, number or space.

♦♦♦ = "2NU" for 230V or 460V (Copeland motor code = TSK, TSC, TSN, TAC, TAD, TFC, TFD)

♦♦♦ = "5PU" for 575V (Copeland motor code = TAE, TFE, TSE)

All compressors ship dry (except two stage compressors - include Y for POE oil, blank for AB oil)

1D will have one unloader

2D will have two unloaders





Copeland Model #	Old Copeland Model #	CFH	ECOLINE BITZER Model #	CFH	Kit #
<b>"K" AIR COOLED CONVENTIONAL COMPRESSORS</b>					
	KAA♦♦007	255	2JES-07-△△△	222	N/A
	KAG♦♦005	185	2KES-05-△△△	173	N/A
	KAG♦♦007	185	2KES-05-△△△	173	N/A
	KAG♦♦010	185	2KES-05-△△△	173	N/A
	KAG♦♦015	185	2KES-05-△△△	173	N/A
	KAJ♦♦007	219	2JES-07-△△△	222	N/A
KAJ♦♦011	KAJ♦♦010	219	2JES-07-△△△	222	N/A
KAK♦♦011	KAK♦♦010	255	2HES-1-△△△	278	N/A
KAK♦♦021	KAK♦♦020	255	2HES-2-△△△	278	N/A
	KAL♦♦010	315	2GES-2-△△△	323	N/A
KAL♦♦016	KAL♦♦015	315	2GES-2-△△△	323	N/A
	KAM♦♦007	169	2KES-05-△△△	173	N/A
	KAM♦♦010	169	2KES-05-△△△	173	N/A
	KAR♦♦010	158	2KES-05-△△△	173	N/A
	KAT♦♦010	388	2FES-2-△△△	407	N/A
	KAT♦♦015	388	2FES-2-△△△	407	N/A
	KAT♦♦020	388	2FES-2-△△△	407	N/A
<b>"E" AIR COOLED CONVENTIONAL COMPRESSORS</b>					
EAD♦♦021	EAD♦♦020	388	2FES-2-△△△	407	N/A
	EAD♦♦032	388	2FES-3-△△△	407	N/A
	EAJ♦♦015	493	2EES-2-△△△	484	N/A
	EAL♦♦020	525	2EES-2-△△△	484	N/A
EAV♦♦021	EAV♦♦020	441	2EES-2-△△△	484	N/A
	ERA♦♦020	338	2GES-2-△△△	323	N/A
ERC♦♦021	ERC♦♦020	338	2GES-2-△△△	323	N/A
	ERF♦♦031	461	2EES-3-△△△	484	N/A
<b>"L" AIR COOLED CONVENTIONAL COMPRESSORS</b>					
LAC♦♦032	LAC♦♦031	815	4FES-3-△△△	770	N/A
LAH♦♦032	LAH♦♦031	695	2CES-3-△△△	692	N/A
LAL♦♦032	LAL♦♦031	774	4FES-3-△△△	770	N/A
	LAM♦♦031	957	4EES-4-△△△	969	N/A
<b>"M" REFRIGERANT COOLED CONVENTIONAL COMPRESSORS</b>					
	MRA♦♦050	1080	4DES-5-△△△	1145	N/A
	MRB♦♦050	1192	4DES-5-△△△	1145	N/A
	MRH♦♦076	1136	4DES-7-△△△	1145	N/A
	MRJ♦♦050	1080	4DES-7-△△△	1145	N/A
<b>"N" REFRIGERANT COOLED CONVENTIONAL COMPRESSORS</b>					
	NRA♦♦050	815	4FES-5-△△△	770	N/A
	NRB♦♦040	698	2CES-4-△△△	692	N/A
NRD♦♦032	NRD♦♦031	815	4FES-3-△△△	770	N/A
	NRD♦♦040	815	4FES-5-△△△	770	N/A
	NRM♦♦050	970	4EES-4-△△△	969	N/A

**PLEASE REVIEW ALL X-REF'S FOR DISPLACMENT AND HIGH/LOW TEMP APPLICATION**

♦ = Blank, hyphen, letter, number or space.

△△△ = "2DU" for 230V (Copeland motor code = TFC, TAC)

△△△ = "4SU" for 460V (Copeland motor code = TFD, TAD)

△△△ = "5SU" for 575V (Copeland motor code = TFE, TAE)

## 1.1 Cross Reference



Copeland Model #	Old Copeland Model #	CFH	ECOLINE BITZER Model #	CFH	Kit #
<b>2D - STANDARD DISCUS MODELS (COPELAND)</b>					
2DA3R58K	2DA♦♦050	1136	4DES-5-△△△	1145	N/A
2DA3F23K	2DA♦♦060	1136	4DES-5-△△△	1145	N/A
2DA3R89K	2DA♦♦075	1136	4DES-7-△△△	1145	N/A
2DB3R61K	2DB♦♦050	1191	4DES-5-△△△	1145	N/A
2DB3F25K	2DB♦♦060	1191	4DES-5-△△△	1145	N/A
2DC3R53K	2DC♦♦050	716	4FES-5-△△△	770	N/A
2DD3R63K	2DD♦♦050	823	4EES-6-△△△	969	N/A
2DF3F16K	2DF♦♦030	907	4EES-4-△△△	969	N/A
2DL3F20K	2DL♦♦040	1008	4EES-4-△△△	969	N/A
2DL3R78K	2DL♦♦075	1008	4DES-7-△△△	1145	N/A
<b>"3" - SERIES</b>					
3AB♦♦032	3AB♦♦031	524	2DES-3-△△△	572	N/A
	3AH♦♦020	664	2CES-3-△△△	692	N/A
3AJ♦♦021	3AJ♦♦020	592	2DES-2-△△△	572	N/A
	3RA♦♦031	628	2DES-3-△△△	572	N/A
<b>"9" - SERIES</b>					
	9RA♦♦050	1371	4VE-10-◇◇◇	1479	N/A
	9RB♦♦050	1615	4TE-9-◇◇◇	1760	N/A
	9RB♦♦076	1615	4TE-9-◇◇◇	1760	N/A
	9RC♦♦076	1615	4TE-9-◇◇◇	1760	N/A
	9RC♦♦101	1615	4TE-12-◇◇◇	1760	N/A
	9RJ♦♦050	1371	4VE-7-◇◇◇	1479	N/A
	9RJ♦♦076	1371	4VE-10-◇◇◇	1479	N/A
	9RP♦♦101	1615	4TE-12-◇◇◇-1D	1760	N/A
	9RS♦♦076	2127	4PE-12-◇◇◇	2067	N/A
	9RS♦♦101	2127	4PE-15-◇◇◇	2067	N/A
	9RS♦♦150	2127	4PE-15-◇◇◇	2067	N/A
	9RT♦♦150	2127	4PE-15-◇◇◇-1D	2067	N/A
	9TH♦♦101	2127	S4G-12.2(Y)-◇◇◇	2954	N/A
	9TK♦♦050	1371	S4T-5.2(Y)-◇◇◇	1377	N/A
	9TL♦♦076	1615	S4N-8.2(Y)-◇◇◇	1956	N/A

**PLEASE REVIEW ALL X-REF'S FOR DISPLACMENT, HIGH/LOW TEMP APPLICATION AND UNLOADERS**

♦ = Blank, hyphen, letter, number or space.

△△△ = "2DU" for 230V (Copeland motor code = TFC, TAC)

△△△ = "4SU" for 460V (Copeland motor code = TFD, TAD)

△△△ = "5SU" for 575V (Copeland motor code = TFE, TAE)

◇◇◇ = "2NU" for 230V or 460V (Copeland motor code = TSK, TSC, TSN, TAC, TAD, TFC, TFD)

◇◇◇ = "5PU" for 575V (Copeland motor code = TAE, TFE, TSE)

All compressors ship dry (except two stage compressors - include Y for POE oil, blank for AB oil)

1D will have one unloader

2D will have one unloader





# Selecting the Bitzer Compressor and Accessories

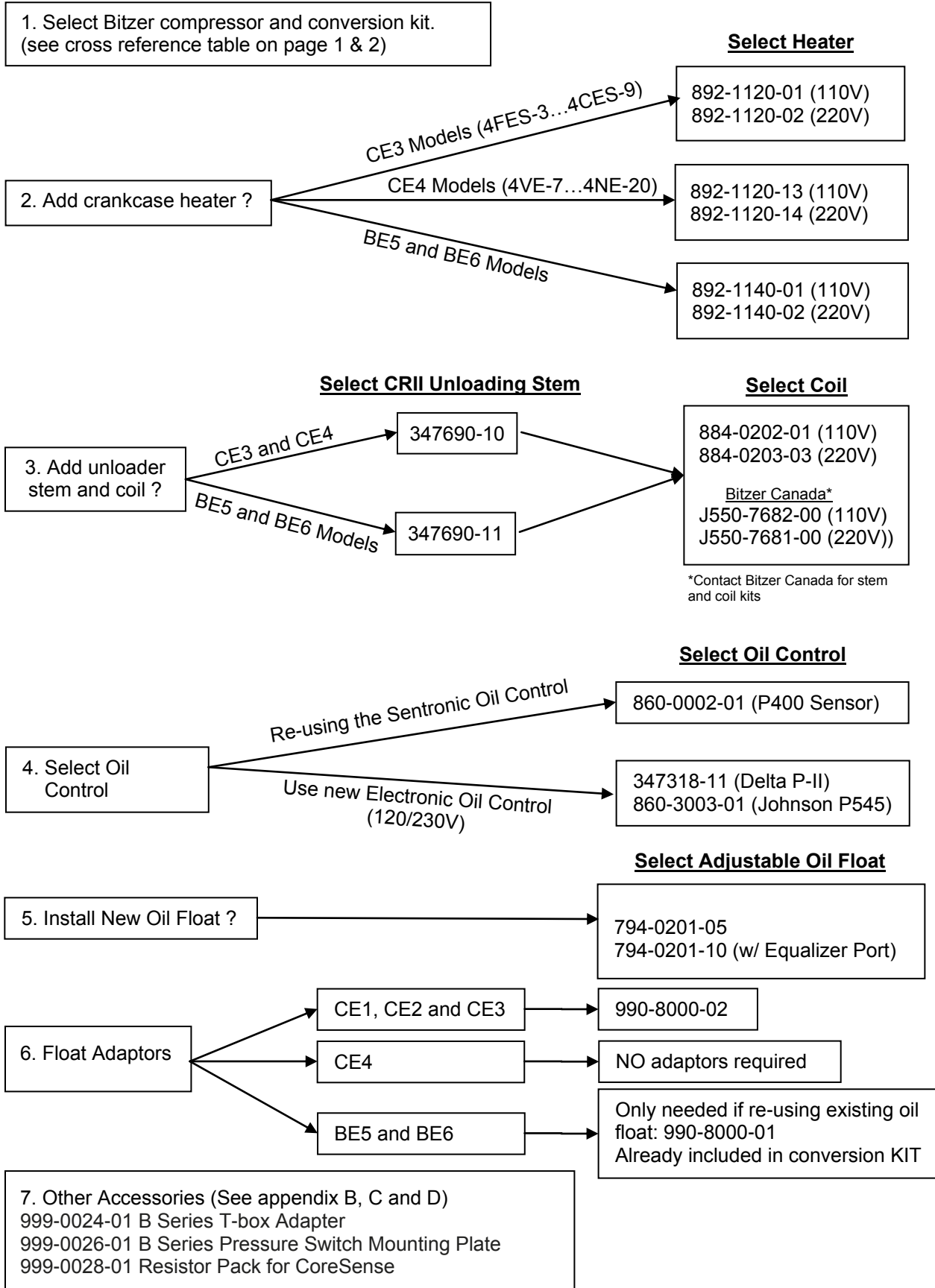



## Additional Selections for Low Temp R22 & R407A/F Applications

Refer to Page 39-42 for additional info

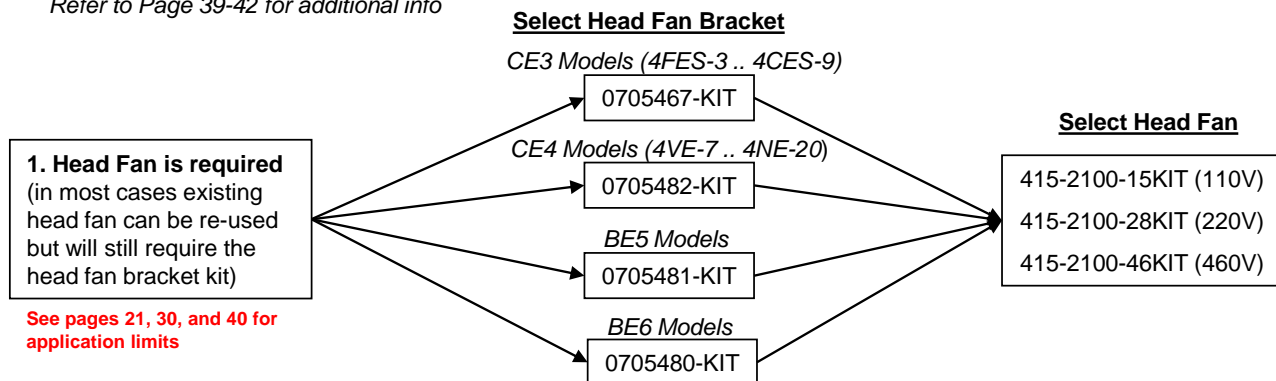

**2. Select a desuperheating method** from the three options below (Valid for CE4, BE5 and BE6 models only):

A. CIC-System – Bitzer’s electronically controlled liquid injection system

- 347702-18 (4VE(S)-7 .. 4NE(S)-20)
- 347702-03 (4JE-15 / 4HE-18)
- 347702-19 (4GE-23)
- 347702-20 (4FE-28)
- 347702-21 (6JE-25 / 6HE-28 / 6GE-34)
- 347702-22 (6FE-44)

- The standard CIC module is 220V. For a 115V module and coils add “-115” to the end of the part number.

B. Reusing the existing Demand Cooling\*

- A110-0001-01 (CE4 Models)
- A110-0002-01 (4JE / 4HE)
- A110-0003-01 (4GE / 4FE)
- A110-0004-01 (BE6 Models)

\*BITZER recommends replacing the existing “injection” solenoid with a standard 3/8” solenoid to avoid the possibility of have two orifices (pressure drops) in the liquid injection line.

C. Sporlan Y1037 Valve

- Select appropriate size based on chart:
- 873-0407-13 (1/3 Ton, 240°F)
  - 873-0109-05 (1/2 Ton, 240°F)
  - 873-0109-11 (1 Ton, 240°F)
  - 873-0109-15 (1-1/2 Ton, 240°F)
  - 873-0109-12 (2 Ton, 240°F)
  - 873-0109-03 (3 Ton, 240°F)
  - 873-0109-04 (5 Ton, 240°F)

Temperature Responsive Expansion Valve - Y1037 - Sizing Chart (Tons)

SST (Evap Temp) Return Gas Temp	-10F		-20F		-30F	
	20F	40F	20F	40F	20F	40F
4VE(S)-7	1/3	1/3	1/2	1/2	1/2	1/2
4TE(S)-9	1/3	1/2	1/2	1/2	1/2	1/2
4PE(S)-12	1/3	1/2	1/2	1	1/2	1
4NE(S)-14	1/3	1/2	1/2	1	1/2	1
4JE-15	1/2	1/2	1/2	1	1	1
4HE-18	1/2	1	1	1	1	1
4GE-23	1/2	1	1	1	1	1 1/2
4FE-28	1/2	1	1	1	1 1/2	1 1/2
6JE-25	1/2	1	1	1 1/2	1 1/2	1 1/2
6HE-28	1/2	1	1	1 1/2	1 1/2	1 1/2
6GE-34	1	1 1/2	1 1/2	2	1 1/2	2
6FE-44	1 1/2	2	2	3	2	3

Saturated Condensing / Liquid Temp = 110°F

**3. Optional Discharge Gas Temp Sensor:** 347023-03 (not required with CIC-System)

**Note:** Oil Cooling is not needed!

# Installation Instructions

## Replacing Copeland 3D with Bitzer CE4

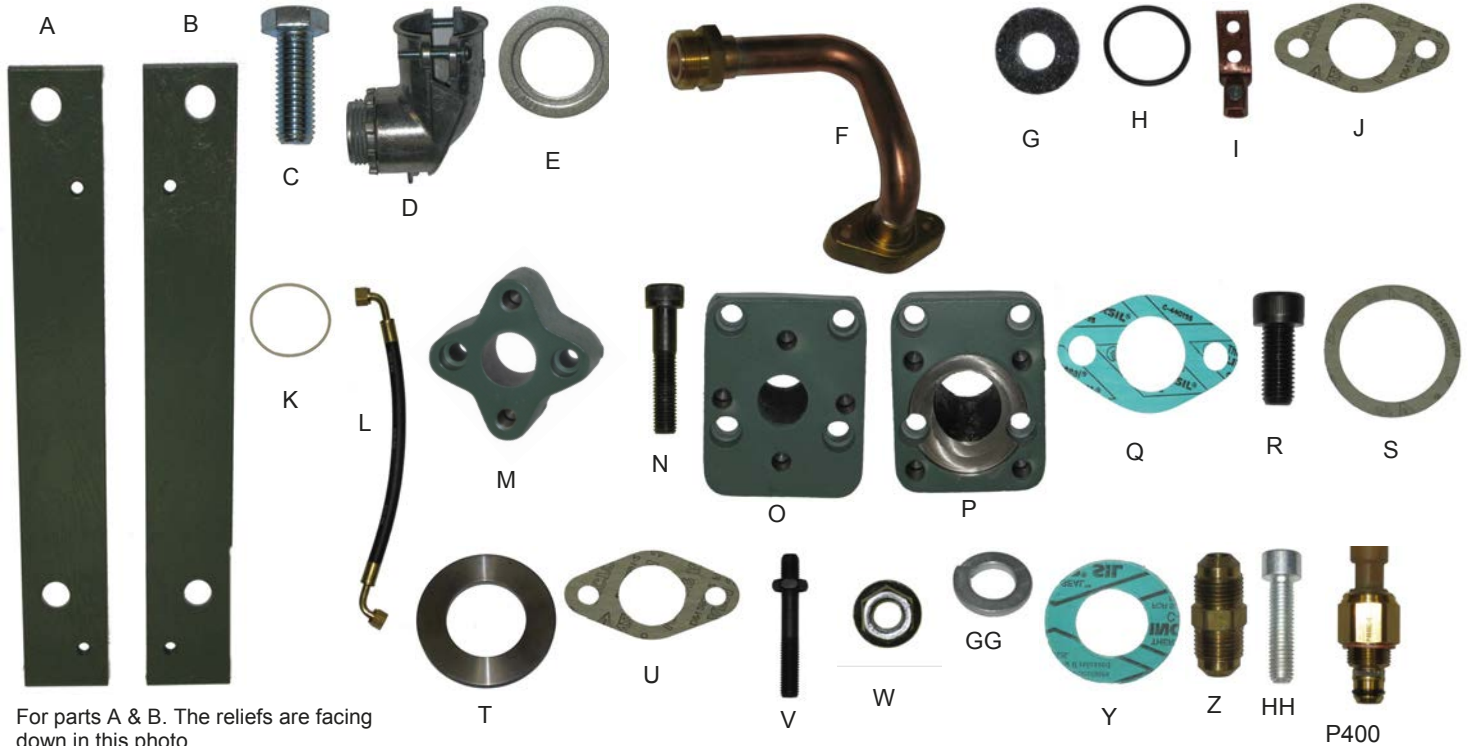

For parts A & B. The reliefs are facing down in this photo.

\*\*\*PARTS NOT TO SCALE\*\*\*

<u>ITEM</u>	<u>QTY</u>	<u>PART #</u>	<u>DESCRIPTION</u>	<u>ITEM</u>	<u>QTY</u>	<u>PART #</u>	<u>DESCRIPTION</u>
<b><u>PARTS IN 542010-00KIT / 542010-01KIT / 542010-02KIT</u></b>				<b><u>PARTS ONLY FOR 542010-00KIT</u></b>			
A	1	542010-11	Base Rail Left Leg	J	1	372704-05	Discharge Gasket - Big
B	1	542010-12	Base Rail Right Leg	U	1	372704-01	Discharge Gasket - Small
C	4	900-4108-12	1/2"-13 X 1-1/2" Hex Screw	M	1	367031-01	2 Bolt>2 Bolt 4C Adapter
D	1	827-1100-02	1" 90° Conduit Elbow Fitting	N	2	380306-26	M10 X 55mm Screw
E	1	937-0611-00	1-1/4" X 1" Reducer Washer	Q	1	X003-4411	Suction Flange Gasket
F	1	B-35268	"Gooseneck" Manifold	<b><u>PARTS ONLY FOR 542010-01KIT</u></b>			
G	8	901-0108-01	1/2" Flat Washer (Zinc)	O	1	367033-01	4 Bolt>2 Bolt 4C Adapter
H	1	372003-39	O-Ring (4C Sightglass)	Q	1	X003-4411	Suction Flange Gasket
I	3	842-1040-00	Wire Lug	R	4	900-4008-30	M12 X 30 Screw (Black)
K	1	372200-04	1-3/4" Rota lock Joint Ring	S	2	372301-02	Suction Gasket (ID 54mm)
L	1	915-1400-00	12" Long Hose (3/8 Fitting)	<b><u>PARTS ONLY FOR 542010-02KIT</u></b>			
Z	1	920-0303-01	Brass Union (3/8 X 3/8)	P	1	367032-01	4 Bolt>4 Bolt 4C Adapter
HH	2	380306-85	M10 X 40 Screw (Zinc)	R	4	900-4008-30	M12 X 30 Screw (Black)
U	1	372704-01	Discharge Flange Gskt - Small	S	3	372301-02	Suction Gasket (ID 54mm)
V	2	900-0003-65	Cylinder Head Ext Bolt (M10)	T	1	930-1944-02	5mm Suction Spacer (C4)
W	2	381901-51	M10 Nut with Flange	Y	2	542010-13	Suction Gasket (ID 37mm)
GG	2	382201-55	A10 Lock Washer				

Other parts: P400 oil sensor (optional) – see Summary of Oil Control Options (page 9).



### Tools Needed

1. 8 & 10mm Allen wrench (hex bit)
2. 17 mm open ended / box wrench
3. 10 mm open ended / box wrench
4. 7/16" open ended / box wrench
5. 9/16" open ended / box wrench
6. 3/4" open ended / box wrench
7. Refrigeration service valve wrench
8. Razor knife
9. Phillips head screwdriver
10. Flathead screwdriver
11. 10mm nutdriver
11. Large channel lock pliers (QTY 2)
12. Hammer
13. 10" adjustable wrench
14. Wire cutters & strippers
15. Multimeter
16. Adjustable Torque Wrench (recommended)
17. Power drill (optional)
18. Knockout set (optional)

It is also recommended to bring extra 1" conduit and fittings if possible. Depending on the system or control device changes, it may be necessary to lengthen a run of conduit and/or create a new conduit line from the control box to the compressor. A knockout set may make it easier to create a larger hole in the terminal box if necessary. Also, a power drill may help to reuse existing brackets by drilling out holes.

Please be aware that while this list should account for most of the tools that are needed, variations in the system could require additional tools. Most metric sizes can be swapped for the English equivalent without any issues. In some cases, using a socket may be preferable over a wrench.

# Removing Copeland 3D Compressor

1. Turn off control power and main power to the compressor. Check both the control circuit and the main power from the compressor breaker with a multimeter to ensure the power has been disconnected.



**DANGER OF ELECTROCUTION!!!**

2. Disconnect and remove all wires from the compressor terminal box.

**NOTE:** Tag control wires for identification to the controls. (See the wiring appendix for wiring instructions for most conversions).

3. Close suction and discharge valves. Close oil supply line and any equalizing lines. Evacuate refrigerant from compressor using approved recovery methods.



**WARNING! COMPRESSOR UNDER PRESSURE WITH CHEMICALS**

4. Disconnect the discharge valve at the Rota lock adapter leaving the adapter flange attached to the compressor. Disconnect the suction valve using a 3/4" wrench. Disconnect all remaining lines from the compressor.
5. Remove all components that are attached to or obstructing the removal of the compressor such as head fans, oil failure, high and low pressure controls.
6. **IMPORTANT: Count the number of spacer washers between the compressor feet and the mounting plate. The same number of washers must be used when installing the Bitzer CE4 compressor.**
7. Remove the compressor.
8. Remove all fittings that will be required for installation of the Bitzer compressor using 7/16" and 9/16" wrenches. See pages 42 and 43 for a list of ports on the compressor.



Figure 2.1

9. Remove oil float by tilting the compressor away from the oil sight glass.

Install a Copeland sight glass if possible (do not remove sight glass from float) to prevent oil from draining out. If the sight glass is not available, drain oil prior to removing oil float.

## Installing the Bitzer CE4 Compressor

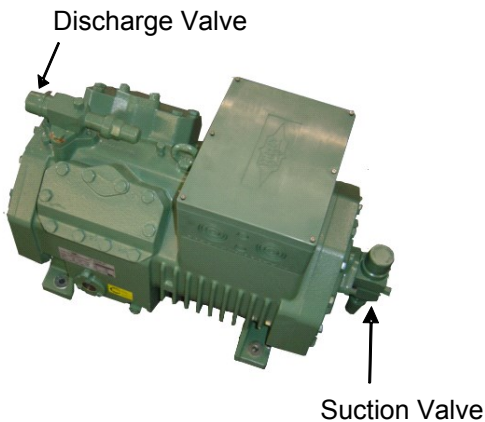

Figure 2.2



**WARNING! Compressor is under pressure.**

1. Relieve pressure from compressor by opening the service valves ports.

**! ATTENTION! Wherever possible, minimize time compressor is open to ambient.**

2. Remove the discharge and suction valves. (17 mm and 8 mm hex bit).

**IMPORANT: Do not knock-out electrical holes in the compressor terminal box at this time. Leave terminal box cover in place. Refer to electrical connection section of manual.**

3. When either an oil float regulator or Trax oil is required, install prior to putting compressor in place only if frame and piping allow it.

If the compressor is not free of oil, tilt compressor away from sight glass (prop up with a 4X4). Remove sight glass and install the oil float using Bitzer sight glass bolts, 10mm wrench and a new o-ring (H).



Figure 2.3



4. Install all the required fittings removed from the old compressor. See pages 42 and 43 for Bitzer fitting locations.



5. Suction Valve Adapter Configuration:

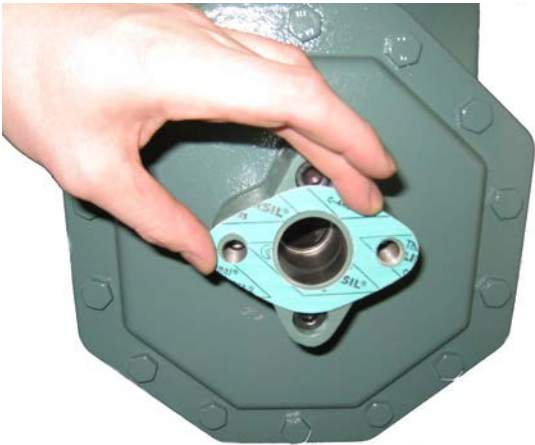

**Figure 2.5a**

Position shown for vertical mounting with gasket (Q).

**2 Bolt Bitzer to 2 Bolt Copeland  
(542010-00KIT)**

- 5a. Replace gasket (U) under the suction strainer and gasket (J) over the strainer. Apply a small amount of oil to both gaskets. Install suction adapter (M) to the 4C compressor with cap screws (N) (8mm hex bit). Torque is 40ft-lb. Adapter will allow for positioning the valve either horizontally or vertically.

**4 Bolt Bitzer to 2 Bolt Copeland  
(542010-01KIT)**

(4PE-15 and 4NE-20 only)

- 5b. Replace both gaskets (S) above and below suction strainer using a small amount of oil. Install suction adapter (O) to the 4C compressor with the 4 cap screws (R) provided in the kit (10mm hex bit). Position the adapter with the throat angle down. Tighten the 4 cap screws evenly and torque to 65 ft-lb.



**Figure 2.5b**

Shown with adaptor (O).

**4 Bolt Bitzer to 4 Bolt Copeland  
(542010-02KIT)**

(4PE-15 and 4NE-20 only)

- 5c. Replace both gaskets (S) above and below suction strainer using a small amount of oil. Install suction adapter (P) to the 4C compressor with the 4 cap screws (R) provided in the kit (10mm hex bit). Position the adapter with the throat angle down. Tighten the 4 cap screws evenly and torque to 65 ft-lb.

**Note for 5a, 5b, 5c.**

If any exposed hardware is not zinc or painted, apply a small amount of grease to top of bolts to prevent rust.



**Figure 2.5c**

Shown with adaptor (P).

6. Install discharge goose neck (F) using gasket (U) to compressor discharge flange with bolts (HH). Apply a small amount of oil to gasket and torque to 40 ft-lb. (8mm hex bit).



**Figure 2.6**

Shown with discharge manifold (F).

7. Place the same number of spacer washers provided with original 3D compressor over the existing mounting holes. (See Figure 2.7a)

**When installing a 4 bolt Bitzer to a 4 bolt Copeland suction adapter kit (542010-02KIT), place two additional 1/2" washers (G) under each leg to raise the compressor for alignment to the suction valve.**

Attach rails to frame with original compressor mounting bolts through the spacer washers to the frame using the original compressor bolts provided, (See Figure 2.7b).

*Rail (A) - mounts to left side with the relief's facing down.*

*Rail (B) - mounts to right side with the relief's facing down.*



**CAUTION! Compressor is extremely heavy.**

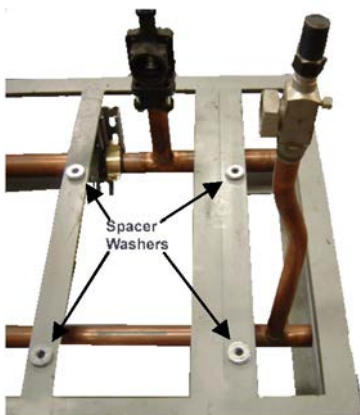

**Figure 2.7a**

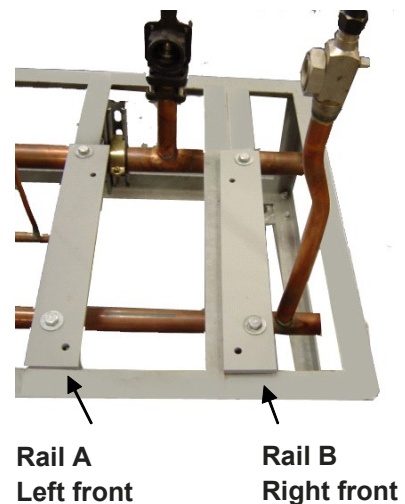

**Figure 2.7b**

8. Place compressor on rails and secure with the 1/2"-13 x 1 1/2" bolts (C), original spacer washers from previous unit, and extra 1/2" washers (G) (if necessary).

9. Suction Valve installation

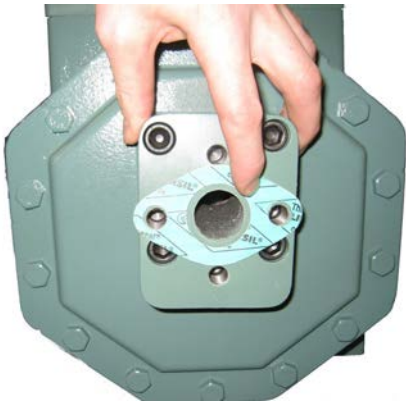

Figure 2.9a

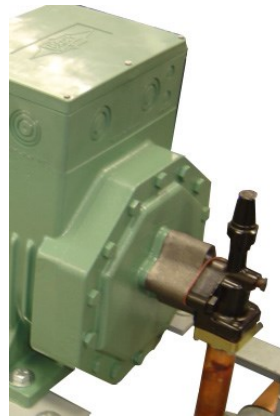

Figure 2.9b



Figure 2.9c

9a. **2 Bolt Bitzer to 2 Bolt Copeland**

9b. **4 Bolt Bitzer to 2 Bolt Copeland**

Place suction valve with gasket (Q) between the valve and the valve adapter. Use the existing Copeland suction valve bolts and tighten evenly with a 3/4" wrench (approx 40 ft-lb).

9c. **4 Bolt Bitzer to 4 Bolt Copeland**

Place one large round gasket (Y) in the adapter hole. Insert the metal spacer. Place a second large round gasket (Y) between the spacer (T) and the suction valve. Using the original Copeland bolts and 3/4" wrench, tighten the suction valve evenly to the suction adapter approx 65 ft-lb).

10. Place the white Teflon ring (K) in the groove on the discharge goose neck (F) and attach to the discharge valve and hand tighten. Tighten connection by securing the goose neck with channel lock pliers and tighten the Rota lock nut with separate channel lock pliers.



Figure 2.10



Figure 2.11

11. Connect oil line to oil float using the hose (L) and 3/8 union (Z) provided in kit.
12. Connect all remaining lines and controls to the compressor. Check for leaks at all connection points.





Figure 2.13a

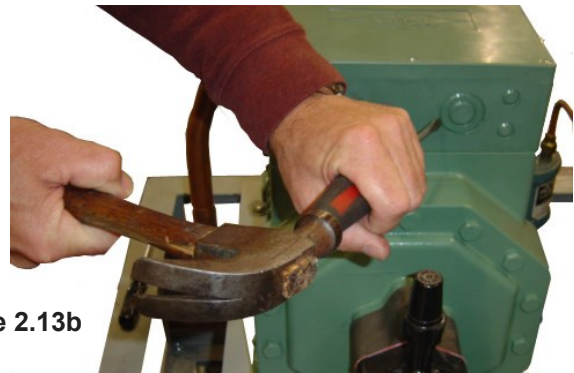

Figure 2.13b

**IMPORTANT : DO NOT REMOVE TERMINAL BOX COVER UNTIL ALL HOLES ARE KNOCKED OUT.**

13. Use a razor to scribe around the the electrical knock-outs that will be used for connecting electrical flex (See Figure 2.13a). Using a hammer and screw driver, tap around the scribed area to carefully knock out the hole. (See Figure 2.13b)

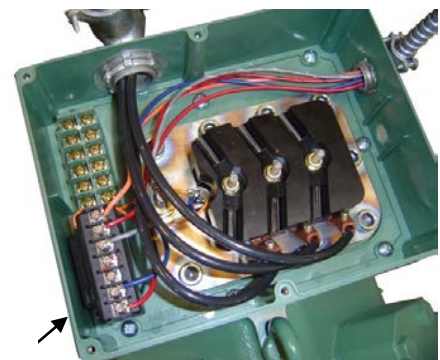

Figure 2.14

14. Remove the terminal box cover. Connect all electrical flex to the terminal box. A 1" X 90° connector (D) has been provided to assist if necessary with the installation.

If the hole is oversized for the connector, use the reducer washers (E) with the 1" connector.

15. Remove the (3) 10 mm nuts holding down the plastic terminal cover (10mm nutdriver). Remove cover and install the jumper bars to correspond to your system voltage (See Figures 2.16a and 2.16b). Install the wire lugs (I) on the terminals marked L1, L2, & L3. Replace the terminal cover. Refer to label inside of terminal box for more detail and other voltages.



Protection Device

Figure 2.15

16. Connect the three phas wires to the terminal lugs and tighten with a flathead screwdriver. Connect the two thermistor wires to spade connectors on the compressor terminal plate.
17. Please see wiring appendix for further instructions.

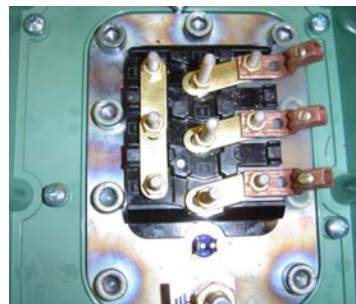

Figure 2.16a  
(208-230/3/60)

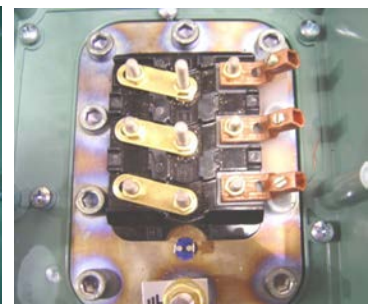

Figure 2.16b  
(460/3/60)

## Installing Bitzer Oil Monitoring System (For S models only. Does not apply to oil pump models)

### OLC-K1 Optical Level Monitor

Bitzer Part: 347318-07 (110V – M20 threads)  
347318-06 (230V – M20 threads)

OLCK1 is comprised of two parts to make installation and maintenance easier.



Oil Level Evaluation Unit

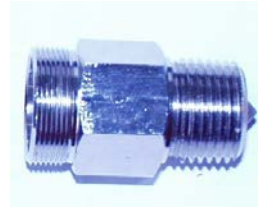

Screw In Unit

1. Release the pressure with both service valves closed and the power supply disconnected.
2. Remove the M20 center bolt and metal gasket. (Figure 2.17). No gasket indicates that the end bell has NPT thread and requires an OLC-K1 with NPT threads.
3. Install the adapter into the bearing cap. Max torque 75Nm or 56ft-lb. (Figure 2.18).

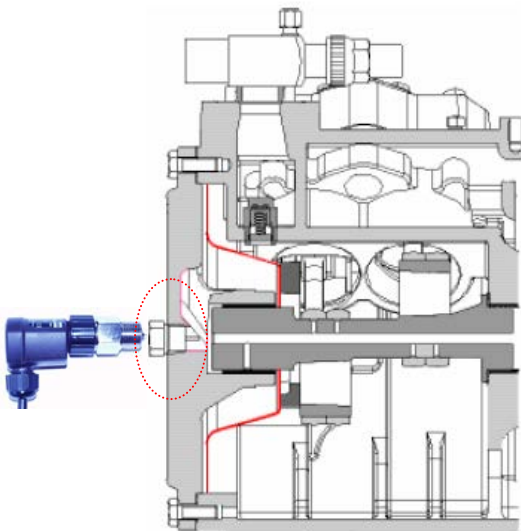

Figure 2.17

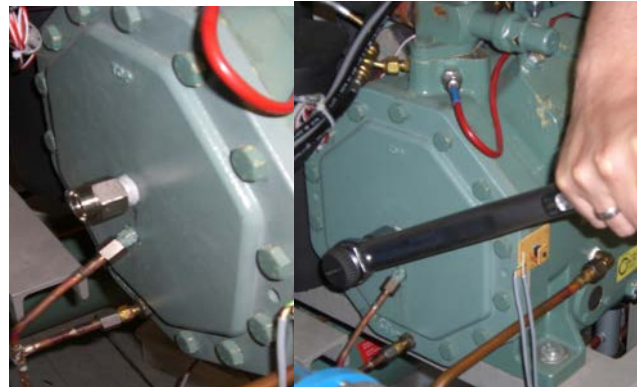

Figure 2.18a

Figure 2.18b

4. Install the electrical sensor into the adapter and tighten the coupling ring approximately 10Nm or 7.4ft-lb (Figure 2.17). Pay attention to the position of the lead (cable exit downwards). For wiring directions, refer to the electrical appendix.

## Mechanical or Electronic Oil Protection (For pump models only. Does not apply to S models)

1. If the Copeland compressor has a mechanical oil safety control, this control can be used with a Bitzer compressor with an oil pump.
2. When using the Johnson electronic control P545-NCB25 the electronic sensor is connected as shown in Figure 2.19. If reusing the Sentronic ask for the P400 oil lube sensor PN 860-0002-01 and connect the Sentronic harness to the P400. For older versions of the Sentronic, use the new harness and wire directly into the Sentronic.

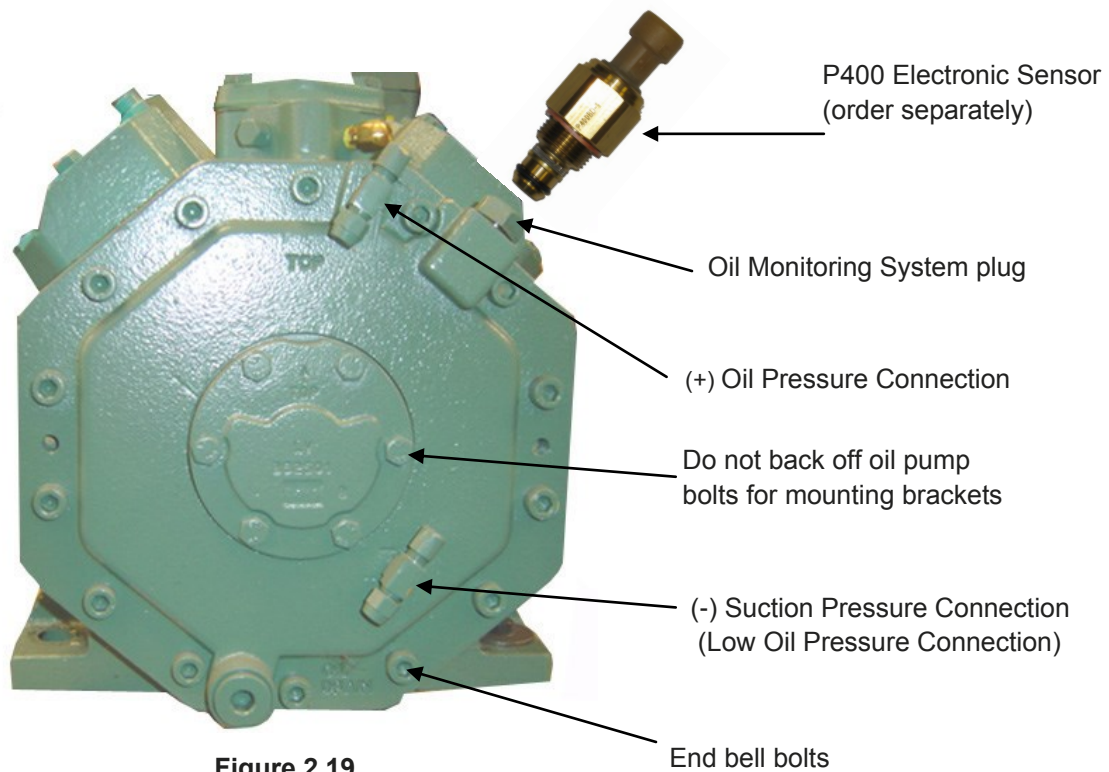

Figure 2.19

3. Mechanical oil safety control connects to the (+)(-) fittings shown in Figure 2.19.
4. High pressure oil is connected to the ¼" SAE marked "+" and the suction is connected to the fitting marked "-".
5. Extension bolts (V) and nuts (W) have been included in the kit to help mount the oil safety controls. Remove a bolt from a cylinder head and replace with an extension bolt. (Torque to 60ft lb). Drill out hole on old mounting bracket and tighten to extension bolt using the M10 nut (W) provided. (Preferred method over using end bell bolts – Do not use oil pump bolts)
6. Refer to the wiring appendix for diagrams for the electrical connections.



## Installing Head Cooling Fans (when required)

1. See the charts below for application limits regarding additional cooling. Note the capacity regulation). Motor 1 is a high temp motor.

2a. If the Copeland 3D compressor has the Copeland head cooling fan mounted on the compressor, this fan can be used with a new bracket as illustrated in Figure 2.20. **Requires Bracket # 0705482.**

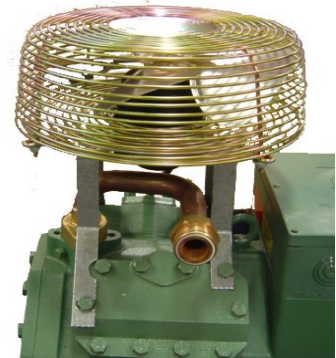

Figure 2.20 - Copeland Head Fan

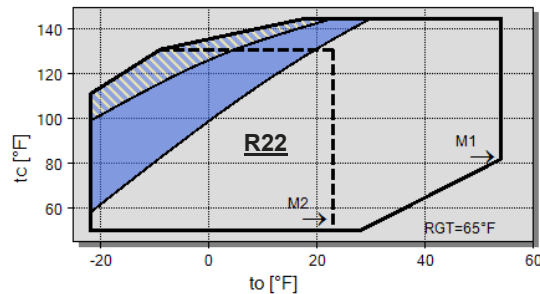

Figure 2.21- Cub 2 Head Fan

2b. If the Copeland 3D compressor has a Cub 2 head cooling fan mounted on the compressor, this fan can also be used with a new bracket as illustrated in Figure 2.21. **Requires Bracket # 0705482 with adapter plate provided with the previous bracket.**

3. Wiring the fan will stay the same as previous compressor. Note: The heads fans can be used with the existing bolts but it is recommended to use extension bolts (V) over washer (GG) and the accompanying nuts (W). Torque head bolts to 60 ft-lb prior to putting on nuts.

Capacity Control:  
100%



**Legend**  
 additional cooling & suction gas superheat ≤35°F  
 additional cooling

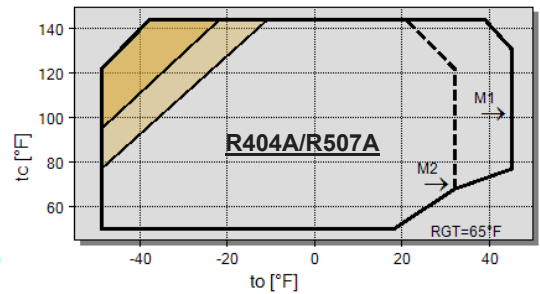

**Legend**  
 additional cooling or suction gas superheat ≤35°F  
 additional cooling or max. toh <40°F

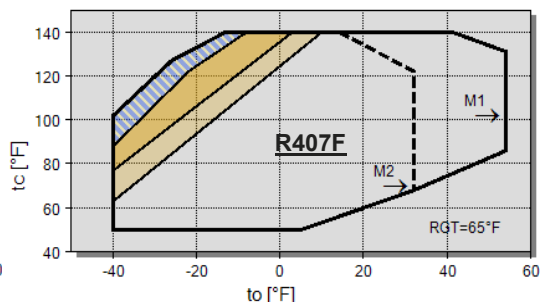
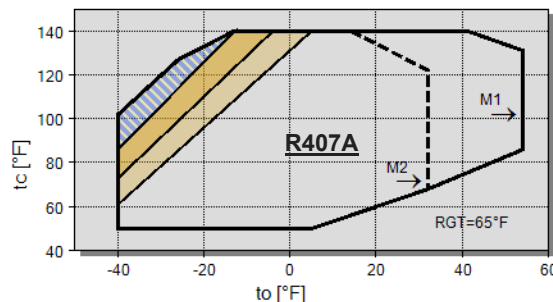

## Installation Instructions

### Replacing Copeland 4D with Bitzer BE5

**KIT PART NUMBER: 542010-07KIT**

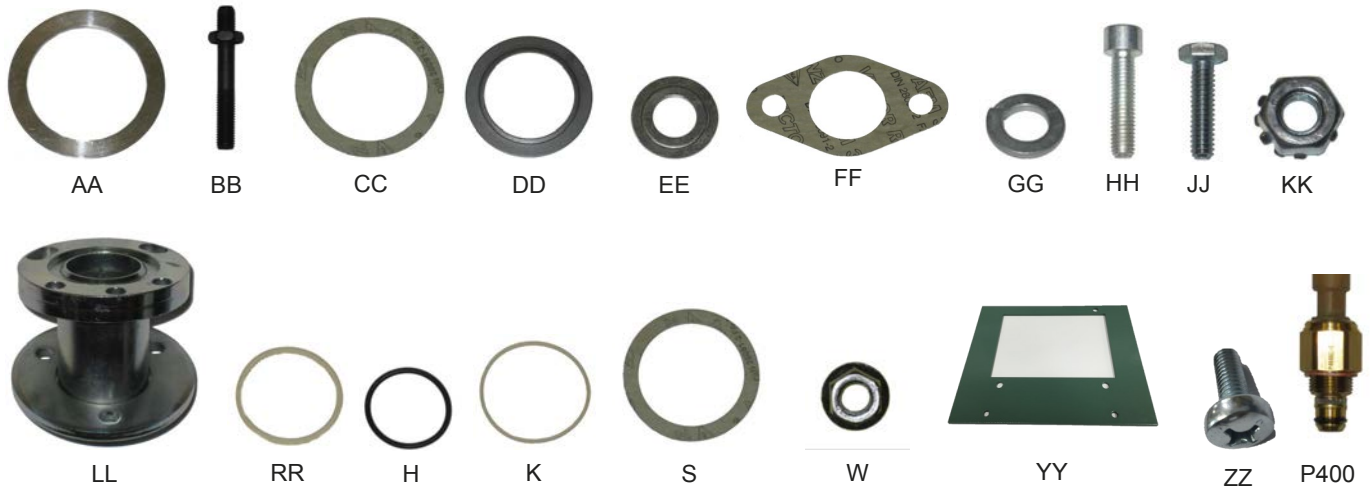

\*\*\*PARTS NOT TO SCALE\*\*\*

<u>ITEM</u>	<u>QTY</u>	<u>PART #</u>	<u>DESCRIPTION</u>
AA	1	930-1944-03	Suction Spacer (w/Lip)
BB	2	900-0003-60	Cylinder Head Extension Bolt (M10X60)
CC	2	372301-03	Suction Gasket (ID 61mm)
DD	2	937-1112-14	1-1/2" X 1-1/4" Reducer Washer
EE	2	937-0408-00	1-1/2" X 1" Reducer Washer
FF	2	372704-01	Discharge Flange Gasket
GG	2	382201-55	A10 Lock Washer
HH	2	380306-85	M10 x 40 Socket Head Cap Screw (Zinc)
JJ	3	900-4104-08	1/4"X 1" Hex Head Screw (Zinc)
KK	3	903-0404-05	1/4" Locking Hex Nut
LL	1	AD-8000-001	Oil Float Adapter, 2" long (4B and 6B)
RR	1	372200-03	1-1/4"Rotalock Joint Ring
H	1	372003-39	O-Ring (4C Sightglass)
K	1	372200-04	1-3/4" Rotalock Joint Ring
S	2	372301-02	Suction Gasket (ID 54mm)
W	2	381901-51	M10 Nut with Flange

Other parts:

Kit p/n 999-0024-01 (optional) - Includes items YY and ZZ. See Appendix B

P400 oil sensor (optional) – see Summary of Oil Control Options (page 9).

Note: If compressor has an extended oil sump, see the 6BE conversion kit on page 27 (542010-08KIT) for additional parts.

#### **Kit for air conditioning application also available:**

Kit part # **542010-07-AC**. Includes parts AA, CC, DD, EE, FF, HH, RR, K, S, BB, W, GG and a crankcase heater. See accessory selection to specify heater part number when ordering.



## Tools Needed

1. 17mm open ended / box wrench
2. 19mm open ended / box wrench
3. 24mm open ended / box wrench
4. 10mm open ended / box wrench
5. 14mm open ended / box wrench
6. 7/16" open ended / box wrench
7. 9/16" open ended / box wrench
8. 3/4" open ended / box wrench or socket
9. 15/16" open ended / box wrench or socket
10. Refrigeration service valve wrench
11. Razor knife
12. Phillips head screwdriver
13. Flathead screwdriver
14. 13mm nutdriver
15. Large channel lock pliers (QTY 2)
16. Hammer
17. 10" adjustable wrench
18. Wire cutters & strippers
19. Multimeter
20. Adjustable torque wrench (recommended)
21. Power drill (optional)
22. Knockout set (optional)

It is also recommended to bring extra 1" conduit and fittings if possible. Depending on the system or control device changes, it may be necessary to lengthen a run of conduit and/or create a new conduit line from the control box to the compressor. A knockout set may make it easier to create a large hole in the terminal box if necessary. Also, a power drill may help to reuse existing brackets by drilling out holes.

Please be aware that while this list should account for most of the tools that are needed, variations in the system could require additional tools. Most metric sizes can be swapped for the English equivalent without any issues. In some cases, using a socket may be preferable over a wrench.

# Removing Copeland 4D Compressor

1. Turn off control power and main power to the compressor. Check both the control circuit and the main power from the compressor breaker with a multimeter to ensure the power has been disconnected.



**DANGER OF ELECTROCUTION!!!**

2. Disconnect and remove all wires from the compressor terminal box.

**NOTE:** Tag control wires for identification to the controls. (See the wiring appendix for wiring instructions for most conversions).

3. Close suction and discharge valves. Close oil supply line and any equalizing lines. Evacuate refrigerant from compressor using approved recovery methods.



**WARNING! COMPRESSOR UNDER PRESSURE WITH CHEMICALS**

4. Disconnect the discharge valve a 3/4" wrench. Disconnect suction valve using a 15/16" socket. Disconnect all remaining lines from the compressor.
5. Remove all components that are attached to or obstructing the removal of the compressor such as head fans, oil failure, high and low pressure controls.
6. **IMPORTANT: Count the number of spacer washers between the compressor feet and the mounting plate. The same number of washers must be used when installing the Bitzer BE5 compressor.**
7. Remove the compressor.
8. Remove all fittings that will be required for installation of the Bitzer compressor using 7/16" and 9/16" wrenches. See pages 42 and 43 for a list of ports on the compressor.



Figure 3.1

9. Remove oil float by tilting the compressor away from the oil sight glass.

Install a Copeland sight glass if possible (do not remove sight glass from float) to prevent oil from draining out. If the sight glass is not available, drain oil prior to removing oil float.

## Installing the Bitzer BE5 Compressor

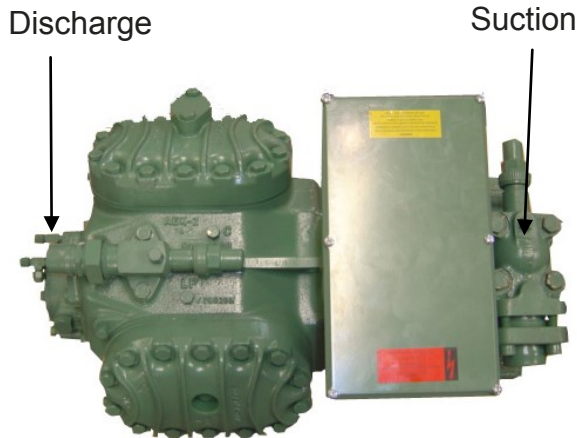

Figure 3.2



Figure 3.3



**WARNING! Compressor is under pressure.**

1. Relieve pressure from compressor by opening the service valves ports.

**! ATTENTION! Wherever possible, minimize time compressor is open to ambient.**

2. Remove the discharge and suction valves. (17 mm, 19 mm or 24 mm and 8 mm hex bit).

**IMPORANT: Do not knock-out electrical holes in the compressor terminal box at this time. Leave terminal box cover in place. Refer to electrical connection section of manual.**

3. When either an oil float regulator or Trax oil is required, install prior to putting compressor in place only if frame and piping allow it.

If the compressor is not free of oil, tilt compressor away from sight glass (prop up with a 4X4). Remove sight glass and install the oil float adaptor (LL) using sight glass bolts, 10mm wrench and a new o-ring (H).



Figure 3.4



4. Install oil float to the oil float adaptor using the 1/4-20x1" bolts (JJ) and nuts (KK) with another o-ring (H) (7/16" wrench). The adapter will add 2 inches; if space is a tight, replace entire oil float with a 4 bolt version, part number 794-0201-05. Reconnect oil line once compressor has been put in place.



5. Install all the required fittings removed from the old compressor. See pages 42 and 43 for Bitzer fitting locations.

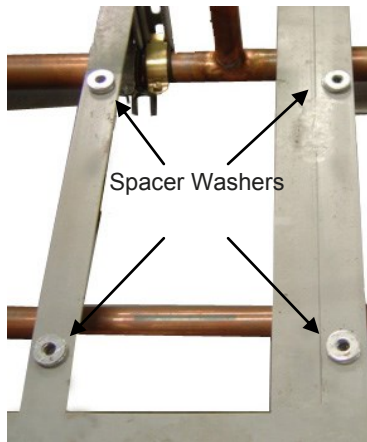

Figure 3.6

6. Place the same number of spacer washers provided with original 4D compressor over the existing mounting holes (Figure 3.6).

7. Mount the compressor on the base using the original mounting bolts.

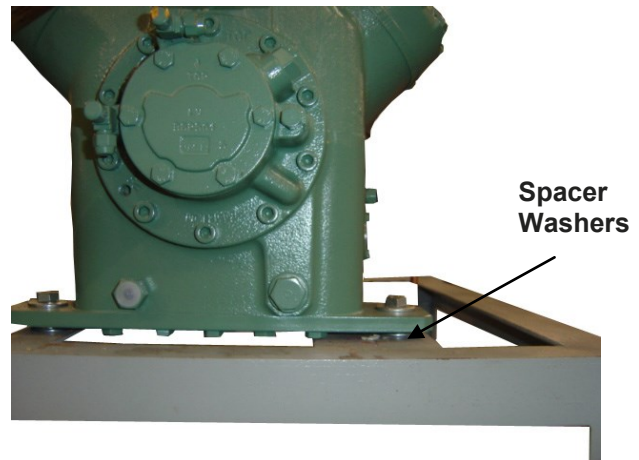

Figure 3.7

#### **IMPORTANT**

**DO NOT TIGHTEN THE MOUNTING BOLTS UNTIL BOTH SUCTION AND DISCHARGE VALVES ARE ALIGNED AND TIGHT.**



**CAUTION! Compressor is extremely heavy**

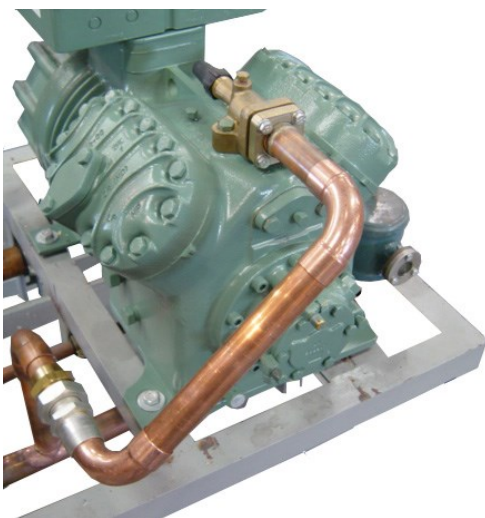

Figure 3.8

8. Install the Copeland discharge valve using the M10x40 bolts (HH) provided with the kit.

Hand tighten any discharge line connectors and the M10x40 discharge valve bolts. After all the bolts have been started by hand, the bolts can be secured evenly at approximately 40ft-lb.



9. In some cases the OEM will prefer to use the front mounting boss with a ball valve in lieu of the service valve as shown in Figure 3.9. It is also acceptable to use the front flange to mount the discharge.

Remove the blank off plate and connect the discharge flange in this position. Remove the service valve and place the blank off plate in the position of the service valve using bolts (HH) provided with the kit and also gasket (FF). Torque is 40ft-lb for both blank off and adapter.

Joint rings (RR) and (K) have been provided if the white Teflon gasket ring needs replacing.



Figure 3.9

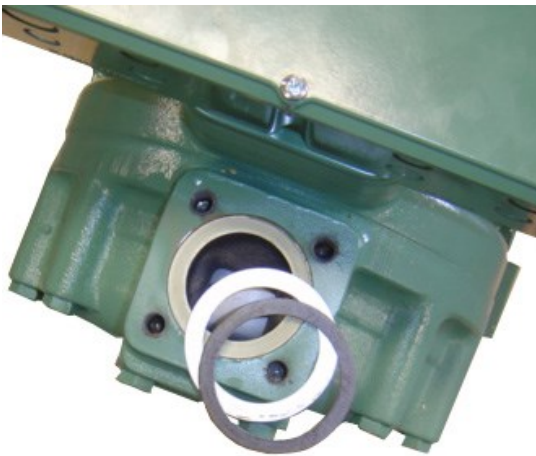

Figure 3.10

10. The suction well for 4BE compressors has two sizes: the 4JE-15 and 4HE-18 have a well ID of 2.75". The 4GE-23 and 4GE-30 have a well ID of 3".

Gaskets (S) have been supplied for the smaller valve well (use single gasket).

In some cases, the larger Copeland valve flange (3-1/8") will need to be positioned above the smaller suction well. Use gasket (CC) then spacer (AA) with lip pointing up, and then a final gasket (S).

11. The upper suction gasket has a tendency to move when the valve is placed on the suction flange.

**IMPORTANT**

Place the bolts in the suction valve and screw them into the flange about 1-2 turns. Center the gasket between the suction spacer and the suction valve with a screwdriver while lifting up on the valve. Tighten the suction valve bolts evenly (torque is 95 ft-lb for large valve and 70ft-lb for the smaller valve).

Check for leaks at all connection points.

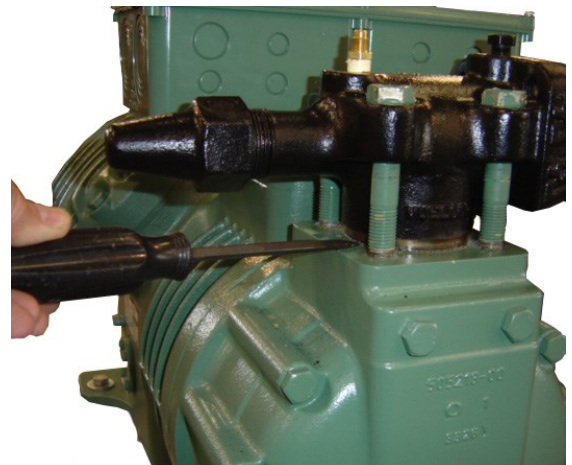

Figure 3.11

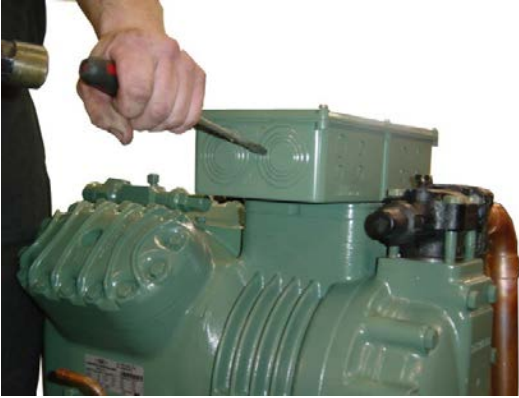

Figure 3.12

12. Leave the terminal box cover attached to the box while knocking out the electrical connector holes.

With a flat bladed screwdriver tap around the knock outs required to make the electrical connections. Use a knock-out punch for better results.

**DO NOT TRY TO KNOCK OUT THE HOLE IN ONE POSITION. DAMAGE TO THE BOX WILL OCCUR.**

Once the holes are knocked out, remove the cover.

13. The dual voltage motor protection device (SE-B3) is already installed in the terminal box. Attach the two thermistor wires to the sensor connectors using the spade connections.

- 13a. The terminal arrangement in Figure 3.13a shows the terminal configuration for 460/3/60 voltage. Install the jumper bars and wire lugs that come with compressor to create the voltage configuration needed (13mm nutdriver).

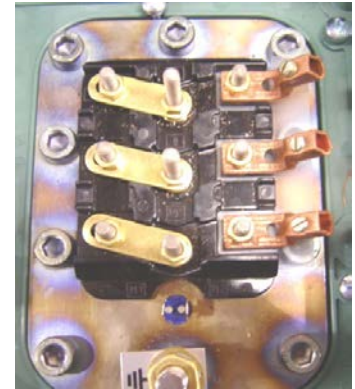

Figure 3.13a  
460V/3/60

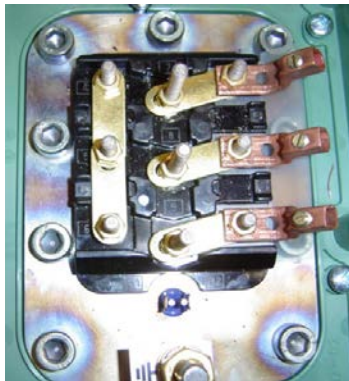

Figure 3.13b  
230V/3/60

- 13b. Figure 3.13b shows the terminal arrangement for a 208-230/3/60 voltage (direct online). Look inside the terminal box cover for more detail and other voltages.

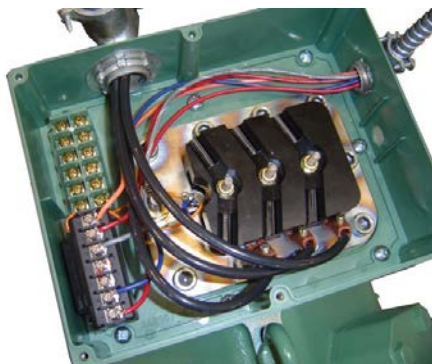

Figure 3.14

14. Install control wires and main power wires. Use spacer washers (DD) and (EE) if the electrical connectors are smaller than the holes.
15. See the wiring appendix for assistance on making the proper connections.

## Mechanical or Electronic Oil Protection (For pump models only. Does not apply to S models)

1. If the Copeland compressor has a mechanical oil safety control, this control can be used with a Bitzer compressor with an oil pump.
2. When using the Johnson electronic control P545-NCB25 the electronic sensor is connected as shown in Figure 3.15. If reusing the Sentronic ask for the P400 oil lube sensor PN 860-0002-01 and connect the Sentronic harness to the P400. For older versions of the Sentronic, use the new harness and wire directly into the Sentronic.



Figure 3.15

3. Mechanical oil safety control connects to the (+)(-) fittings shown in figure 3.15.
4. High pressure oil is connected to the ¼"SAE marked "+" and the suction is connected to the fitting marked "-".
5. Extension bolts (BB) and nuts (W) have been included in the kit to help mount the oil safety controls. Remove a bolt from a cylinder head and replace with an extension bolt (Torque to 60ftlb). Drill out hole on old mounting bracket and attach it the extension bolt (BB) using the M10 nut (W) provided. (Preferred method over using bearing cap bolts – Do not use oil pump bolts)
6. Refer to the wiring appendix for diagrams for the electrical connections.





## Installing Head Cooling Fans (when required)

1. See the charts below for application limits and when head fans are recommended. (Note the capacity regulation). Motor 1 is a high temp motor.

**Note:** If oil cooling existed on the Copeland model, it is not use with the Bitzer compressor.

2. Install head fan bracket on the 4 inner head bolts per figure 3.16. Mount the existing fan to the bracket (**Part #: 0705481**) using the 3 screws provided with the existing fan.

3. Wiring the fan will stay the same as the previous compressor.



**Figure 3.16**

Note: The heads fans can be used with the existing bolts but it is recommended to use (4) extension bolts (BB) over washer (GG) and accompanying nuts (W) (not included in kit). Torque the head bolts to 60ft-lb prior to putting on nuts.

**Capacity Control:  
100%**

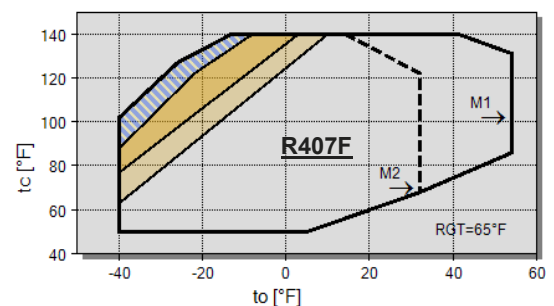
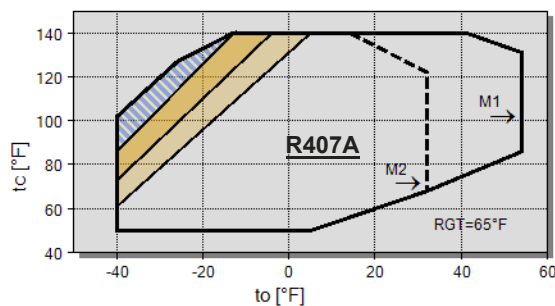
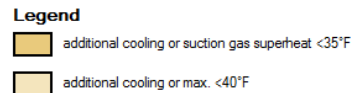
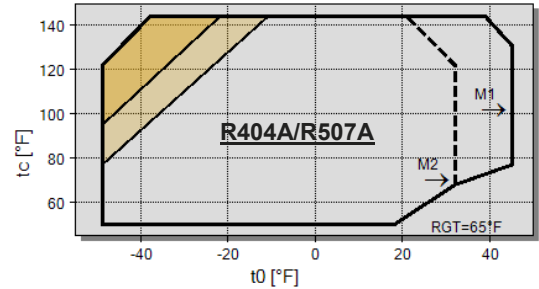
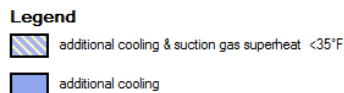
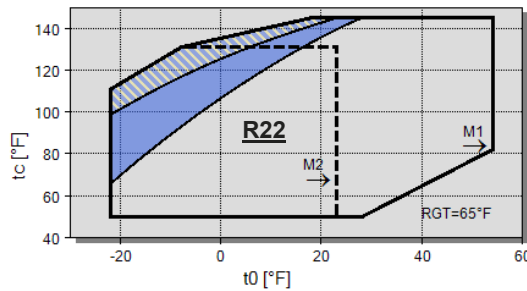

# Installation Instructions

## Replacing Copeland 6D with Bitzer BE6

**KIT PART NUMBER: 542010-08KIT**

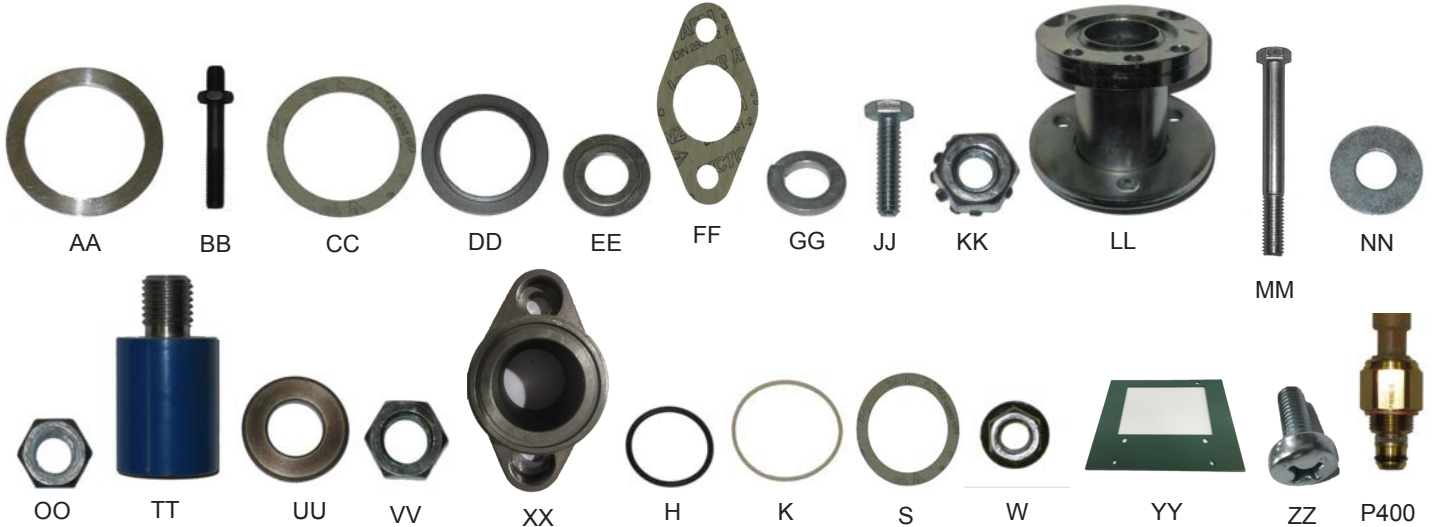

\*\*\*PARTS NOT TO SCALE\*\*\*

<u>ITEM</u>	<u>QTY</u>	<u>PART #</u>	<u>DESCRIPTION</u>
AA	1	930-1944-03	Suction Spacer (with lip)
BB	2	900-0003-60	Cylinder Head Extension Bolt (M10X60)
CC	2	372301-03	Suction Gasket (ID 61mm)
DD	2	937-1112-14	1-1/2" X 1-1/4" Reducer Washer
EE	2	937-0408-00	1-1/2" X 1" Reducer Washer
FF	1	372704-01	Discharge Flange Gasket
GG	2	382201-55	A10 Lock Washer
JJ	3	900-4104-08	1/4"X 1" Hex Head Screw (Zinc)
KK	3	903-0404-05	1/4" Locking Hex Nut
LL	1	AD-8000-001	Oil Float Adapter, 2" long, (4B and 6B)
MM	4	900-4107-44	7/6"x 4" Hex Head Screw (Zinc)
NN	8	901-0107-00	7/6" Flat Washer (Zinc)
OO	4	903-0107-08	7/16" Hex Nut
TT	4	930-1944-04	6B Extender Foot (Adds 2" ht; 3/4"-10 Thread)
UU	2	901-0104-07	3/4" Flat Washer, 1/4" Thick
VV	4	903-1314-01	3/4" Nut
H	2	372003-39	O-Ring (C4 Sightglass)
XX	1	367023-01	1-3/4" Discharge Flange
K	1	372200-04	1-3/4" Rotalock Joint Ring
S	2	372301-02	Suction Gasket (ID 54mm)
W	2	381901-51	M10 Nut with Flange

Other parts:

Kit p/n 999-0024-01 (optional) - Includes items YY and ZZ. See Appendix B.

P400 oil sensor (optional) – see Summary of Oil Control Options (page 9).

**Kit for air conditioning application also available:** Kit part # **542010-08-AC** is also available. Includes parts AA, CC, DD, EE, K, S, BB, W, GG and a crankcase heater. See accessory selection to specify heater part number when ordering. Also, specify 990-8000-01 if the oil float adapter (w/hardware) is necessary.



## Tools Needed

1. 17mm open ended / box wrench
2. 19mm open ended / box wrench
3. 24mm open ended / box wrench
4. 10mm open ended / box wrench
5. 14mm open ended / box wrench
6. 7/16" open ended / box wrench
7. 9/16" open ended / box wrench
8. 3/4" open ended / box wrench or socket
9. 15/16" open ended / box wrench or socket
10. Refrigeration service valve wrench
11. Razor knife
12. Phillips head screwdriver
13. Flathead screwdriver
14. 13mm nutdriver
15. Large channel lock pliers (QTY 2)
16. Hammer
17. 10" adjustable wrench
18. Wire cutters & strippers
19. Multimeter
20. Adjustable torque wrench (recommended)
21. Power drill (optional)
22. Knockout set (optional)

It is also recommended to bring extra 1" conduit and fittings if possible. Depending on the system or control device changes, it may be necessary to lengthen a run of conduit and/or create a new conduit line from the control box to the compressor. A knockout set may make it easier to create a large hole in the terminal box if necessary. Also, a power drill may help to reuse existing brackets by drilling out holes.

Please be aware that while this list should account for most of the tools that are needed, variations in the system could require additional tools. Most metric sizes can be swapped for the English equivalent without any issues. In some cases, using a socket may be preferable over a wrench.



## Removing Copeland 6D Compressor

1. Turn off control power and main power to the compressor. Check both the control circuit and the main power from the compressor breaker with a multimeter to ensure the power has been disconnected.



**DANGER OF ELECTROCUTION!!!**

2. Disconnect and remove all wires from the compressor terminal box.

**NOTE:** See **Appendix B** for instructions on how to re-use the Copeland terminal box. This is possible if there is sufficient length in the incoming power wires/conduit.

**NOTE:** Tag control wires for identification to the controls. (See the wiring appendix for wiring instructions for most conversions).

3. Close suction and discharge valves. Close oil supply line and any equalizing lines. Evacuate refrigerant from compressor using approved recovery methods.



**WARNING! COMPRESSOR UNDER PRESSURE WITH CHEMICALS**

4. Disconnect the discharge valve a 3/4" wrench. Disconnect suction valve using a 15/16" socket. Disconnect all remaining lines from the compressor.
5. Remove all components that are attached to or obstructing the removal of the compressor such as head fans, oil failure, high and low pressure controls.
6. **IMPORTANT: Count the number of spacer washers between the compressor feet and the mounting plate. The same number of washers must be used when installing the Bitzer BE6 compressor.**
7. Remove the compressor.
8. Remove all fittings that will be required for installation of the Bitzer compressor using 7/16" and 9/16" wrenches. See pages 42 and 43 for a list of ports on the compressor.



Figure 4.1

9. Remove oil float by tilting the compressor away from the oil sight glass.

Install a Copeland sight glass if possible (do not remove sight glass from float) to prevent oil from draining out. If the sight glass is not available, drain oil prior to removing oil float.

## Installing the Bitzer BE6 Compressor

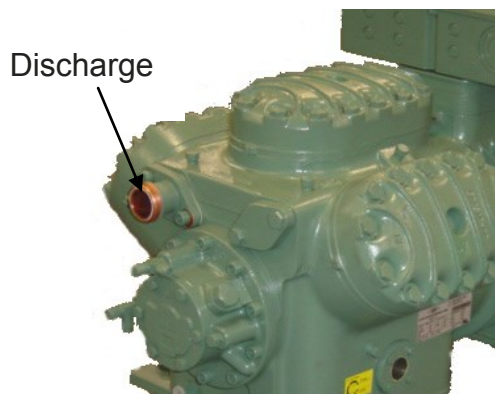

Figure 4.2

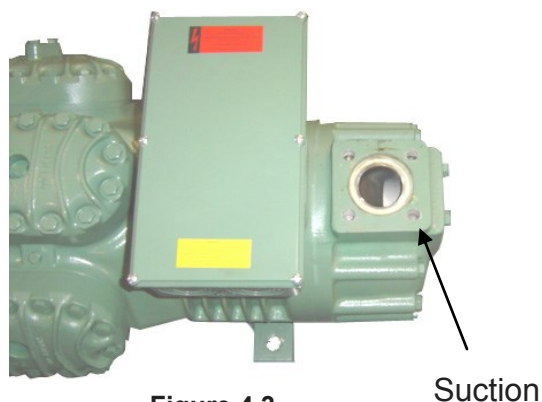

Figure 4.3



**WARNING!** Compressor is under pressure.

1. Relieve pressure from compressor by opening the service valves ports.

**! ATTENTION!** Wherever possible, minimize time compressor is open to ambient.

2. Remove the discharge using channel locks or 2" wrench and suction valves using a .24 mm wrench

**IMPORANT: Do not knock-out electrical holes in the compressor terminal box at this time. Leave terminal box cover in place. Refer to electrical connection section of manual.**

3. When either an oil float regulator or Trax oil is required, install prior to putting compressor in place only if frame and piping allow it.

If the compressor is not free of oil, tilt compressor away from sight glass (prop up with a 4X4). Remove sight glass and install the oil float adaptor (LL) using sight glass bolts, 10mm wrench and a new o-ring (H).



Figure 4.4



4. Install oil float to the oil float adapter using the 1/4-20x1" bolts (JJ) and nuts (KK) with another o-ring (H) (7/16" wrench). The adapter will add 2 inches; if space is a tight, replace entire oil float with a 4 bolt version, part number 794-0201-05. If adding the feet extenders, see step 6 before removing the prop holding the compressor at a tilt. Reconnect oil line once compressor has been put in place.
5. Install all the required fittings removed from the old compressor. See pages 42 and 43 for the Bitzer fitting locations.

## Low Temperature with Extended Oil Sump



Figure 4.6a

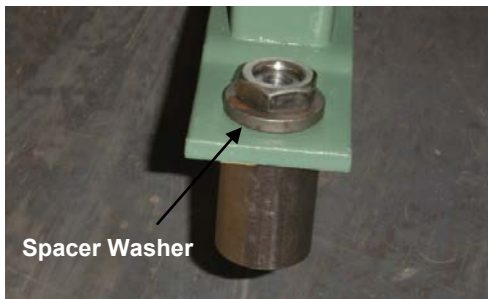

Figure 4.6b



Figure 4.6c

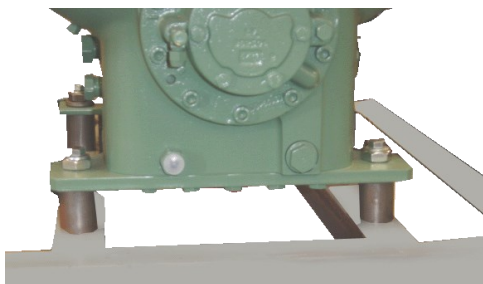

Figure 4.6d

6. When an extended sump is used on a Copeland low temperature 6D, feet extenders will be required to raise the Bitzer compressor to align the suction and discharge piping. Figure 4.6c

To install the extenders (TT), tilt the compressor on its side and prop the compressor with the shipping pallet. Figure 4.6a

Install the feet extenders on the tilted side with the 3/4" jam nuts (V V) provided. Figures 4.6a & 4.6b

Place the 1/4" spacer (UU) washer between the top of the compressor foot and the jam nut, **on the rear feet only**. Figure 4.6b

Repeat the above steps on the other side of the compressor to install all four extender feet. Place compressor on frame. Figures 4.6c & 4.6d

Lift the compressor in place with a hoist and align the mounting holes to the base holes. Insert the 7/16" bolts (MM) and washers (NN) through the adapter feet. Secure with the 7/16" washer (NN) and nuts (OO).

**IMPORTANT: Do not tighten the bolts until the suction and discharge valves are aligned and tight.**

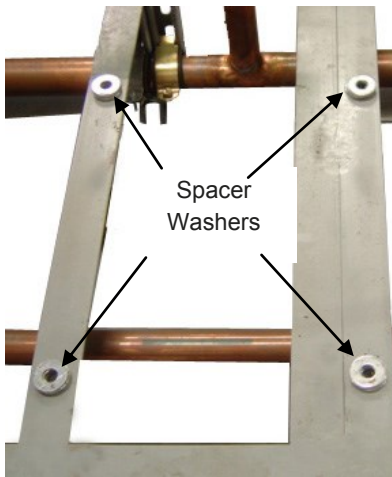

Figure 4.7

7. If the extenders are not needed, place the same number of spacer washers provided with original 6D compressor over the existing mounting holes.

8. Mount the compressor on the base using the original mounting bolts.

**IMPORTANT**

**DO NOT TIGHTEN THE MOUNTING BOLTS UNTIL BOTH SUCTION AND DISCHARGE VALVES ARE ALIGNED AND TIGHT.**

 **CAUTION! Compressor is extremely heavy**



Figure 4.8

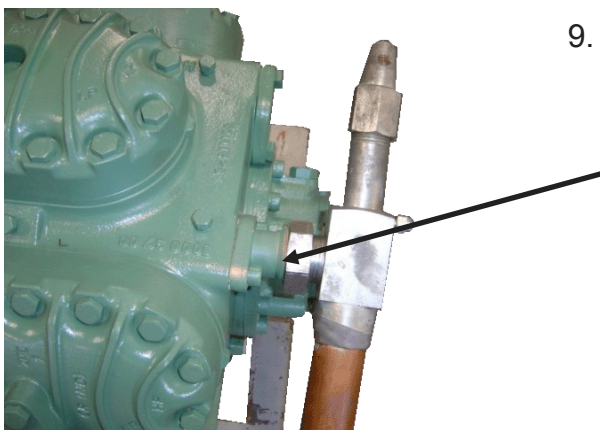

Figure 4.9

9. Install the Copeland discharge valve by attaching the female Rota lock nut on the discharge valve to the discharge adapter. BE6 compressors now come with a 2" rotolock connection (Fig. 4.9), if a 1 3/4" connection is required, replace the existing flange with the 1-3/4" flange (XX) and gasket (FF). The existing bolts must be re-used.

Replace the joint ring (K) if it is damaged.

Hand tighten any discharge line connectors.



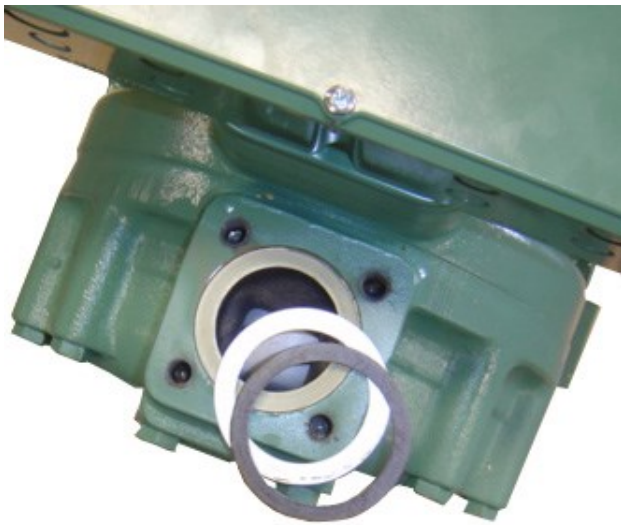

Figure 4.10

10. The suction well for the BE6 compressors has one size which is 3" ID.

The larger Copeland valve flange will need to be positioned above the smaller suction well. Use gasket (CC) then spacer (AA) with lip facing up and then a final gasket (S).

11. The upper suction gasket has a tendency to move when the valve is placed on the suction flange.

#### **IMPORTANT**

Place the bolts in the suction valve and screw them into the flange about 1 -2 turns. Center the gasket between the suction spacer and the suction valve with a screw driver while lifting up on the valve.

Tighten the suction valve bolts evenly.

Torque is 95ft-lb.

Check for leaks at all connection points.

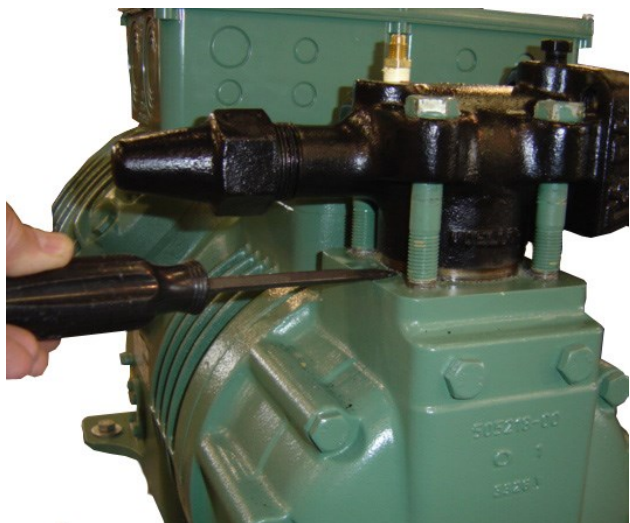

Figure 4.11



Figure 4.12

12. Leave the terminal box cover attached to the box while knocking out the electrical connector holes.

With a flat bladed screwdriver tap around the knock outs required to make the electrical connections. Use a knockout punch for better results.

**DO NOT TRY TO KNOCK OUT THE HOLE IN ONE POSITION. DAMAGE TO THE BOX WILL OCCUR.**

Once the holes are knocked out, remove the cover.

13. The dual voltage motor protection device (SE-B3) is already installed in the terminal box. Attach the two thermistor wires to the sensor connectors using the spade connections.

13a. The terminal arrangement in Figure 4.13a shows the terminal configuration for 460/3/60 voltage. Install the jumper bars and wire lugs that come with compressor to create the voltage configuration needed (13mm nutdriver).

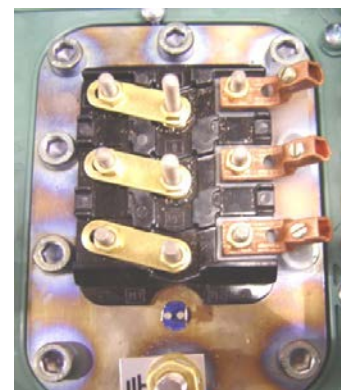

Figure 4.13a  
460V/3/60

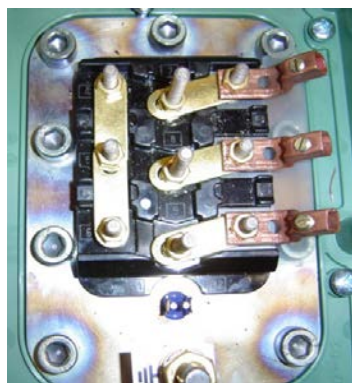

Figure 4.13b  
230V/3/60

13b. Figure 4.13b shows the terminal arrangement for a 208-230/3/60 voltage (direct online). Look inside the terminal box cover for more detail and other voltages.

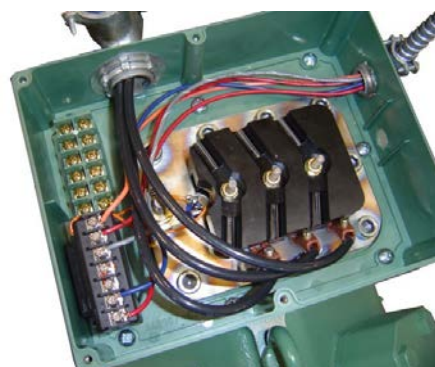

Figure 4.14

14. Install control wires and main power wires. Use spacer washers (DD) and (EE) if the electrical connectors are smaller than the holes.

15. See the wiring appendix for assistance on making the proper connections.



## Mechanical or Electronic Oil Protection (For pump models only. Does not apply to S models)

1. If the Copeland compressor has a mechanical oil safety control, this control can be used with a Bitzer compressor with an oil pump.
2. When using the Johnson electronic control P545-NCB25 the electronic sensor is connected as shown in Figure 4.15. If reusing the Sentronic ask for the P400 oil lube sensor PN 860-0002-01 and connect the Sentronic harness to the P400. For older versions of the Sentronic, use the new harness and wire directly into the Sentronic.



Figure 4.15

3. Mechanical oil safety control connects to the (+)(-) fittings shown in figure 4.15.
4. High pressure oil is connected to the 1/4"SAE marked "+" and the suction is connected to the fitting marked "-".
5. Extension bolts (BB) and nuts (W) have been included in the kit to help mount the oil safety controls. Remove a bolt from a cylinder head and replace with an extension bolt (Torque to 60ftlb). Drill out hole on old mounting bracket and attach it the extension bolt (BB) using the M10 nut (W) provided. (Preferred method over using bearing cap bolts – Do not use oil pump bolts)
6. Refer to the wiring appendix for diagrams for the electrical connections.



## Installing Head Cooling Fans (when required)

1. See the charts for application limits and when head fans are recommended. (Note the capacity regulation). Motor 1 is a high temp motor.

**Note:** If oil cooling existed on the Copeland model, it is not use with the Bitzer compressor.

2. Install head fan bracket on the 4 inner head bolts per figure 4.16. Mount the existing fan to the bracket (**Part #: 0705480**) using the 3 screws provided with the existing fan.
3. Wiring the fan will stay the same as the previous compressor.

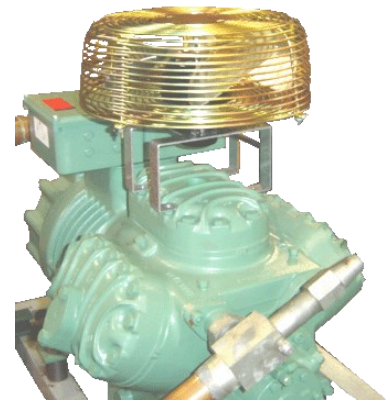

**Figure 4.16**

Note: The heads fans can be used with the existing bolts but it is recommended to use extension bolts (BB) over washer (GG) and accompanying nuts (W) (not included in kit). Torque the head bolts to 60ft-lb prior to putting on nuts.

Capacity Control: 100%

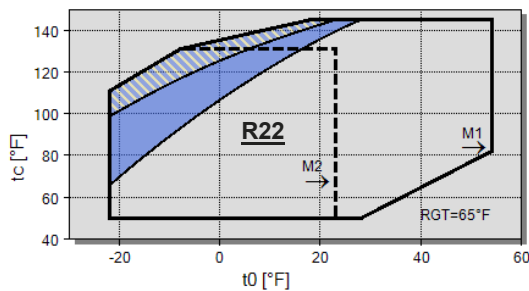

**Legend**  
 additional cooling & suction gas superheat <35°F  
 additional cooling

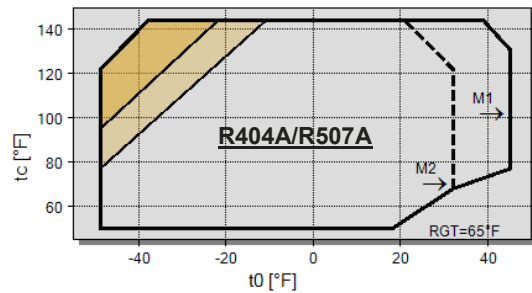

**Legend**  
 additional cooling or suction gas superheat <35°F  
 additional cooling or max. <40°F

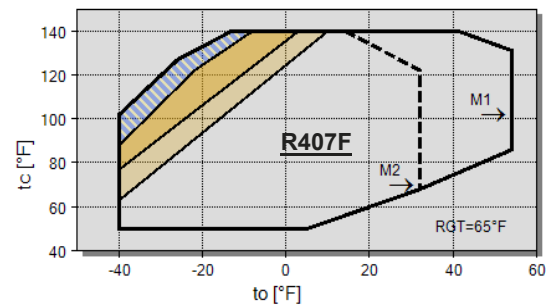
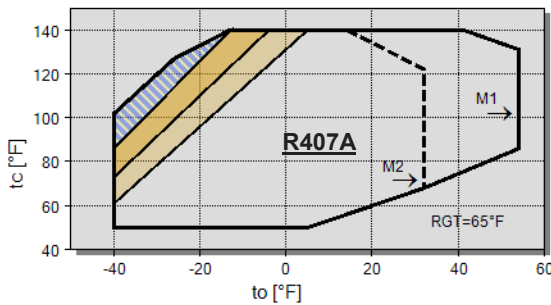

# ECOLINE Dimensions and Port Locations

**CE4**

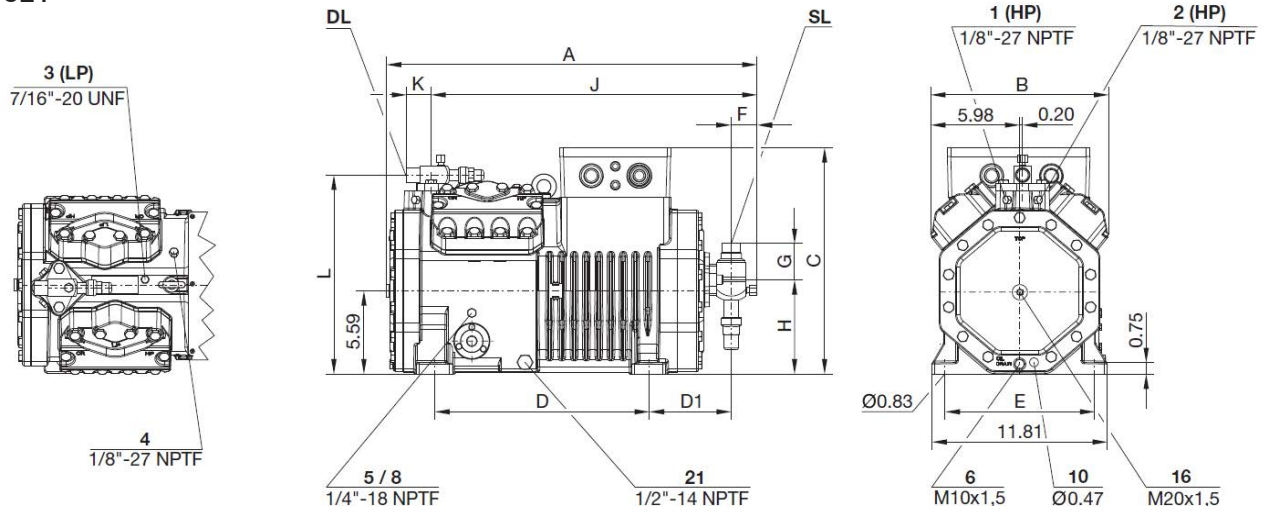

**BE5**

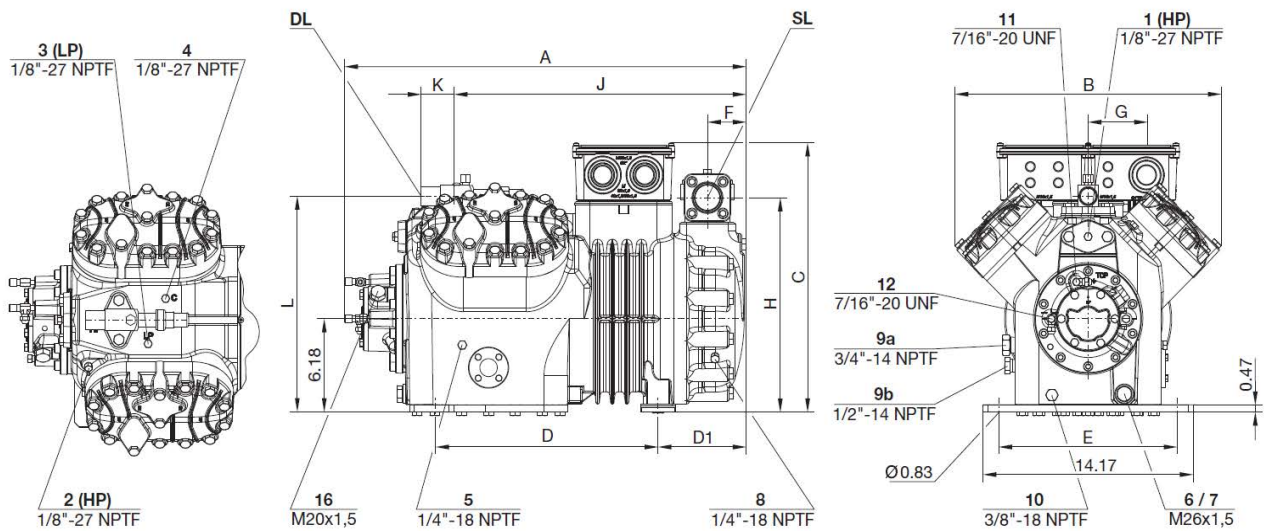

**BE6**

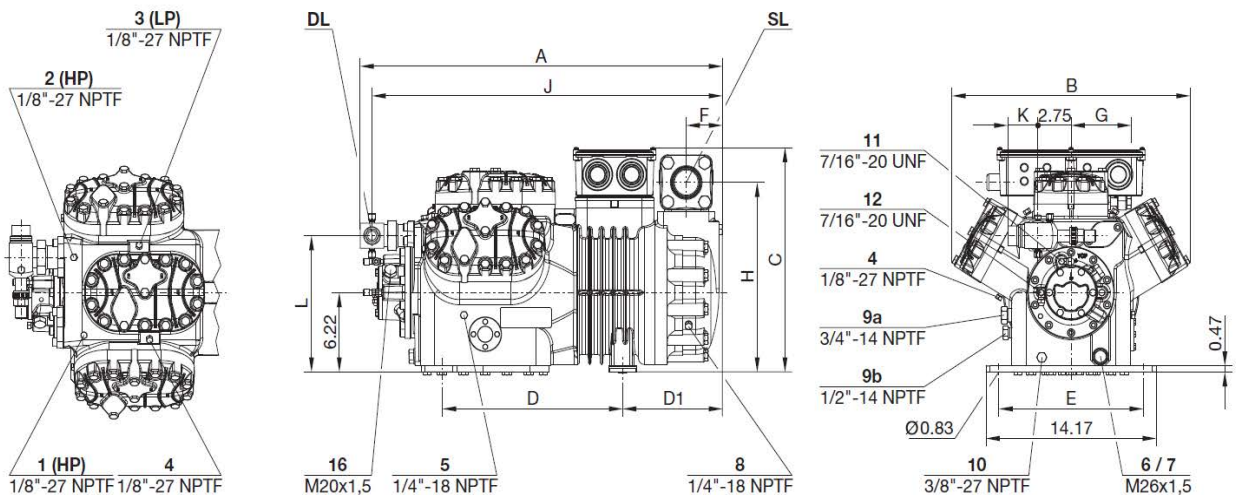



## ECOLINE Dimensions

Compressor	A	B	C	D	D1	E	F	G	H	J	K	L				
4VE(S)-7	24.92	11.93	15.16	14.45	5.51	10.08	1.73	2.20	6.34	21.97	2.21	13.31				
4VE(S)-10								2.52		21.93						
4TE(S)-9								1.89		4.33			6.81	22.91		
4TE(S)-12								1.73		2.52			6.34	21.93		
4PE(S)-12								6.38		1.89			4.33	6.81	22.91	
4PE(S)-15								25.91		5.51			1.73	2.52	6.34	21.93
4NE(S)-14								24.92		6.38			1.89	4.33	6.81	22.91
4NE(S)-20								25.91		5.94			2.60	4.33	14.21	19.72
4JE-15	27.09	17.95	18.50	15.00	7.87	12.01	3.43	5.00	14.84	21.61	2.21	14.25				
4JE-22										20.43						
4HE-18										21.61						
4HE-25										29.02						
4GE-23										27.80						
4GE-30										29.02						
4FE-28										7.87						
4FE-30										3.43						
6JE-25	30.16	19.80	18.50	15.00	8.31	12.01	2.99	5.00	14.84	29.13	2.52	10.67				
6JE-33										30.35						
6HE-28										29.13						
6HE-35										30.35						
6GE-34										30.16						
6GE-44										8.31						
6FE-44										9.53						
6FE-50										31.10						
6FE-50	28.71															

## Port Locations

<b>1</b>	High pressure connection (HP)	<b>9a</b>	Gas equalization (parallel operation)
<b>2</b>	Discharge gas temp sensor (HP) or LI sensor	<b>9b</b>	Oil equalization (parallel operation)
<b>3</b>	Low pressure connection (LP)	<b>10</b>	Crankcase heater
<b>4</b>	Liquid Injection spray nozzle (LP)	<b>11</b>	High pressure oil connection (7/16" - 20 UNF)
<b>5</b>	Oil fill plug	<b>12</b>	Low pressure oil connection (7/16" - 20 UNF)
<b>6</b>	Oil drain (magnetic screw)	<b>16</b>	Connection for oil monitoring (M20 Thread)
<b>7</b>	Oil filter	<b>21</b>	Connection for oil service valve
<b>8</b>	Oil return (oil separator)		



## R22 & R407A/F LOW TEMP APPLICATIONS

The use of R22 or R407A/F in a low temp application can place a high demand on the compressor and lubricant. Discharge gas temperatures can reach very high values not sustainable by the compressor. It is necessary to cool the return gas to ensure the performance of the compressor will prevail. Regardless of how this is achieved, a discharge hi-temp safety device should be used as a secondary preventive measure for protecting the compressor.

The blue areas below indicate the application limits that require additional cooling (note head fan, superheat settings, and liquid injection areas). For other applications, use the BITZER software (free download from [www.BITZERUS.com](http://www.BITZERUS.com)).

**STANDARD**

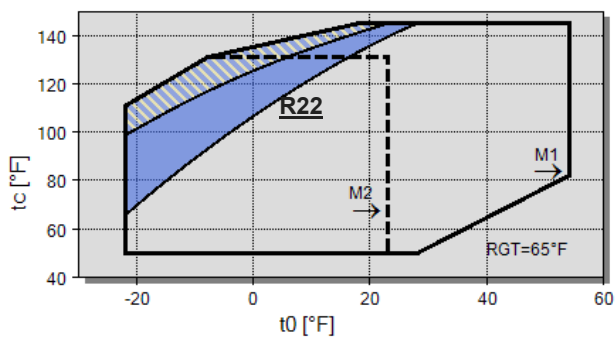

**Legend**

- additional cooling & suction gas superheat  $\leq 35^{\circ}\text{F}$
- additional cooling

**CIC**

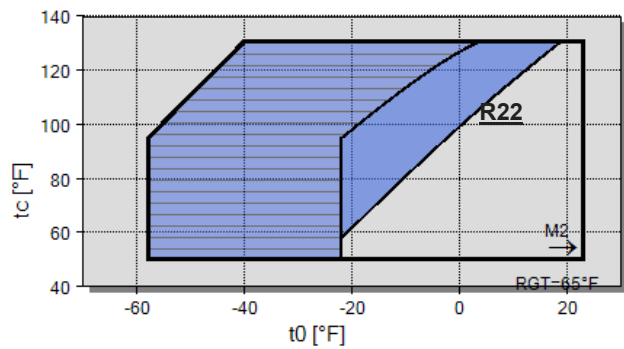

**Legend**

- additional cooling & CIC
- additional cooling

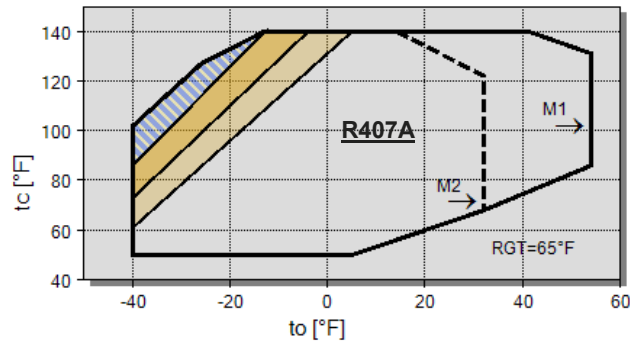

**Legend**

- additional cooling & suction gas superheat  $\leq 35^{\circ}\text{F}$
- additional cooling or suction gas superheat  $\leq 35^{\circ}\text{F}$
- additional cooling or max. toh  $< 40^{\circ}\text{F}$

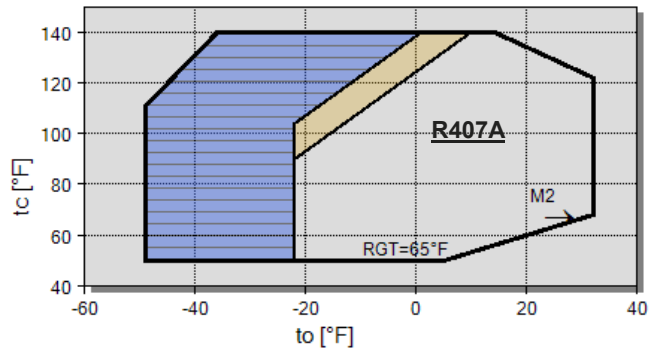

**Legend**

- additional cooling & CIC
- additional cooling or max. toh  $< 40^{\circ}\text{F}$

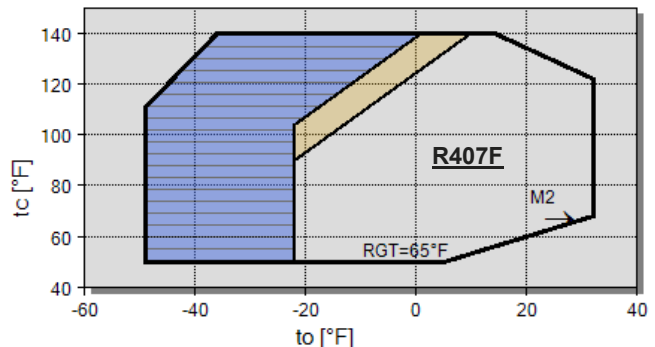
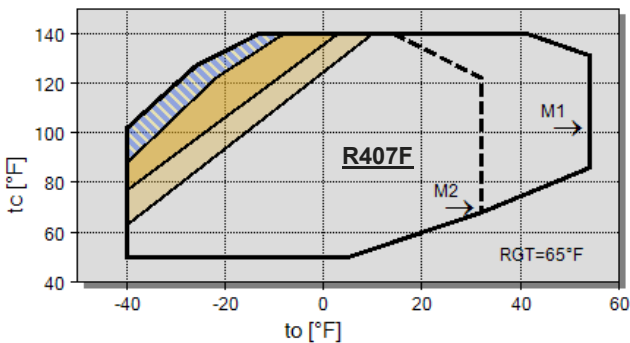



Three options for de-superheating are available:

### 1. Using the CIC-System

The BITZER CIC system is a reliable electronically controlled refrigerant injection device for limiting the temperature of 4 and 6 cylinder single stage reciprocating compressors operating in low temperature systems with R22 or R407A/F. (Refer to KT-130 for detailed information and installation instructions).

### 2. Using a Temperature Responsive Expansion Valve

The Sporlan TREV (Y1037) valves are available from various refrigeration wholesalers and have a variety of set points. Valves suitable for BITZER compressors are also available directly through BITZER US. These valves regulate the discharge gas temperature to 240°F. Most valves have 3/8" SAE connections and the bulb sensor is 5 feet long. The only exception is the 1/3 ton valve which has 3/8 sweat connection and a 30 inch long sensor. See the chart on page 10 for valve sizes and part numbers.

BITZER recommends injecting into the low pressure port of the compressor after the motor. These ports are shown in the figure below as port 4. For 6 cylinder compressors, install a manifold to the high pressure (bottom) side of the left head so that it has two injection ports (4 and 4a).

Be sure to install the TREV bulb 4-8 inches away from the discharge valve and properly insulate it to prevent influence from the ambient and head fan air.

It is also recommended to install a solenoid valve before the Y-1037 to ensure the liquid feed is off when the compressor is off.

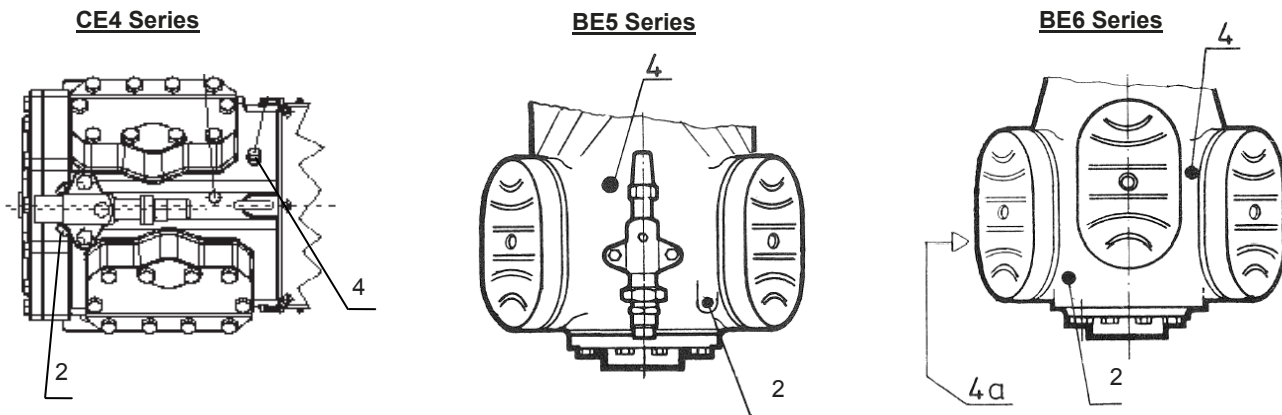

## Installing a Discharge Temperature Sensor

As an additional step to protect compressors from damage, the use of a discharge temperature sensor as a secondary backup safety is recommended. This safety has proved especially useful when using R22 or R407A/F in low temp applications, even when an injection device is in place to cool the return gas.

BITZER offers a discharge temperature sensor (part # 347023-03) that will open the SE-B INT module at 140°C / 284°F.

### To Use:

Apply Teflon tape sealant to the threads of the sensor and install into port 2 (see figure above). The sensor must not be installed further downstream (e.g. discharge piping) due to the ability of the gas to lose heat quickly. This would allow the temperature in the head to reach unsafe temperatures.

Wire the sensor according to this diagram:

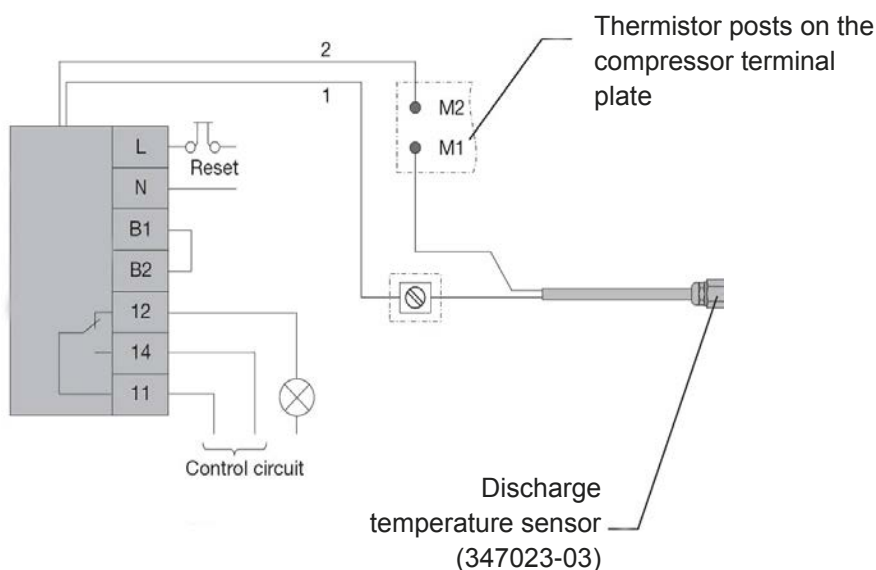



### 3. Re-Using “Demand Cooling” Components

In many instances, Copeland already has its own "Demand Cooling" used with the compressor that is being replaced. This can be re-used if desired but requires a special port on a cylinder head that does not already exist. This can be drilled and tapped (1/8"NPT) into the existing head but it is recommended to purchase the special head kit from BITZER US. This includes additional necessary components such as the nozzle, gasket and discharge temp safety sensor.

BITZER recommends replacing the existing “injection” solenoid with a standard 3/8” solenoid to avoid the possibility of have two orifices (pressure drops) in the liquid injection line.

<u>Kit:</u>	<u>A110-0001-01</u>	<u>for all 4CE models</u>
<u>Qty</u>	<u>Part Number</u>	<u>Description</u>
1	302371-25NPT	Cylinder head w/1/8" NPT port
1	372623-01	Plate to head gasket, 4C
1	361001-01	Spray nozzle, 1.17
1	347023-03	Discharge temp sensor, 140°C

<u>Kit:</u>	<u>A110-0002-01</u>	<u>for models 4JE &amp; 4HE</u>
<u>Qty</u>	<u>Part Number</u>	<u>Description</u>
1	302375-25NPT	Cylinder head w/1/8" NPT port
1	372616-03	Plate to head gasket, B series
1	361001-01	Spray nozzle, 1.17
1	347023-03	Discharge temp sensor, 140°C

<u>Kit:</u>	<u>A110-0003-01</u>	<u>for models 4GE</u>
<u>Qty</u>	<u>Part Number</u>	<u>Description</u>
1	302375-21NPT	Cylinder head w/1/8" NPT port
1	372616-03	Plate to head gasket, B series
1	361001-02	Spray nozzle, 1.65
1	347023-03	Discharge temp sensor, 140°C

<u>Kit:</u>	<u>A110-0004-01</u>	<u>for all 6BE models</u>
<u>Qty</u>	<u>Part Number</u>	<u>Description</u>
1	302375-21NPT	Cylinder head w/1/8" NPT port
1	372616-03	Plate to head gasket, B series
1	361001-01	Spray nozzle, 1.17 (Side -4a)
1	361001-02	Spray nozzle, 1.65 (Top -4)
1	347023-03	Discharge temp sensor, 140°C

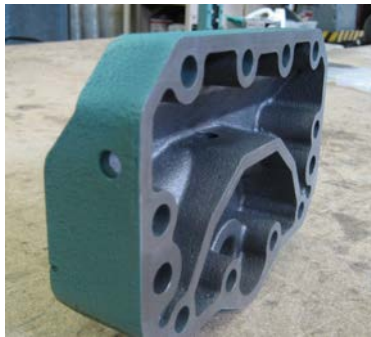

302371-25NPT



302375-21NPT

Note: Drill and Tap approximate 1/2” from the edge of the head (must be in high pressure side).



### INSTALLATION DIRECTIONS

1. Remove the BITZER compressor cylinder head on the sightglass side (right) for the 6BE compressors and the opposite side (left) for 4 cylinder models.
2. Install a compressor cylinder head with a 1/8" NPT tapped hole. Make sure to use a new head gasket (metal). When installing a new head, remove the old head and gasket and keep the valve plate and valve plate gasket in place. Use a new head gasket and torque all bolts in two steps up to 60 ft-lb.
3. Apply Teflon tape sealant to the brass injection nozzle(s) P/N 361001-01 and/or 361001-02. Install the nozzles into the compressor at port 4 (see figure above). Do not remove the nozzle that is already installed on the Demand Cooling device. For 6 cylinder compressors, run a manifold to the high pressure (bottom) side of the left head so that it has two injection ports (4 and 4a).
4. Remove the Copeland Demand Cooling sensor from the Copeland compressor and apply Teflon tape sealant to the threads. Re-install into the 1/8" NPT port of the new BITZER cylinder head (302371-25NPT or 302375-21NPT).
5. Remove the Demand Cooling electronic module and re-use, finding a suitable method of support.
6. Disconnect the Demand Cooling injection solenoid from the Copeland compressor and re-pipe to the nozzle(s) installed on the BITZER compressor. Find a suitable method to support the valve and related piping to avoid strain and eliminate all vibrations on pipe work that may lead to breaks or fractures.
7. Check for leaks at all points before pressurizing the compressor with refrigerant.
8. It is recommended to also install a discharge temperature sensor into port 2.

Note: The Copeland Demand cooling will open at 292°F and close after reaching 282°F. An alarm activates at 310°F. The discharge temperature sensor will activate at 284°F but if installed in port 2 will not alarm due to the increased temperature of the head.



# Nomenclature

## BITZER

**4NES - 14 - 2NU - 1Y**

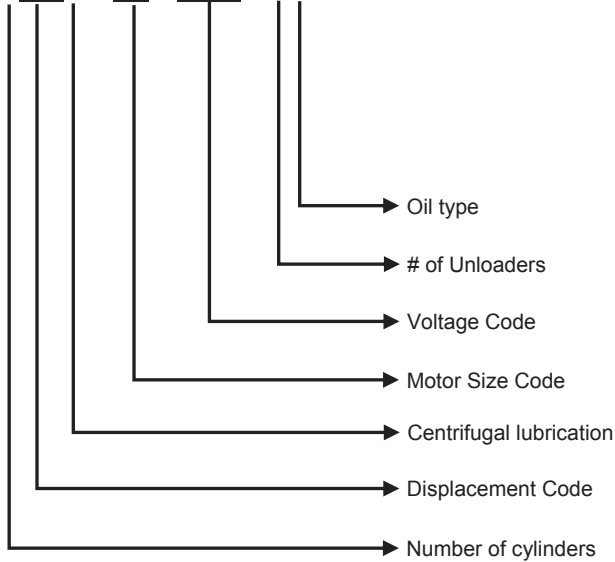

Note: The suffix (e.g. "-1Y") is used for ordering and shipping purposes but is not displayed on the data tag (nameplate) of the compressor.

## COPELAND

### Current Copeland Model #

**3DA3F18K0-TFC-800**

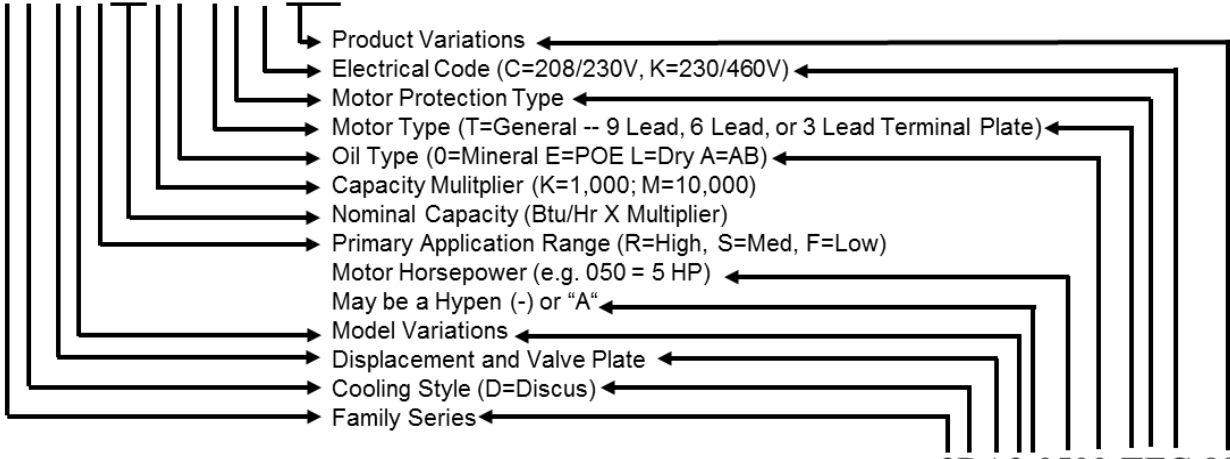

**3DA3-0500-TFC-800**

**Previous Copeland Model #**



# Wiring Diagram Located in Terminal Box

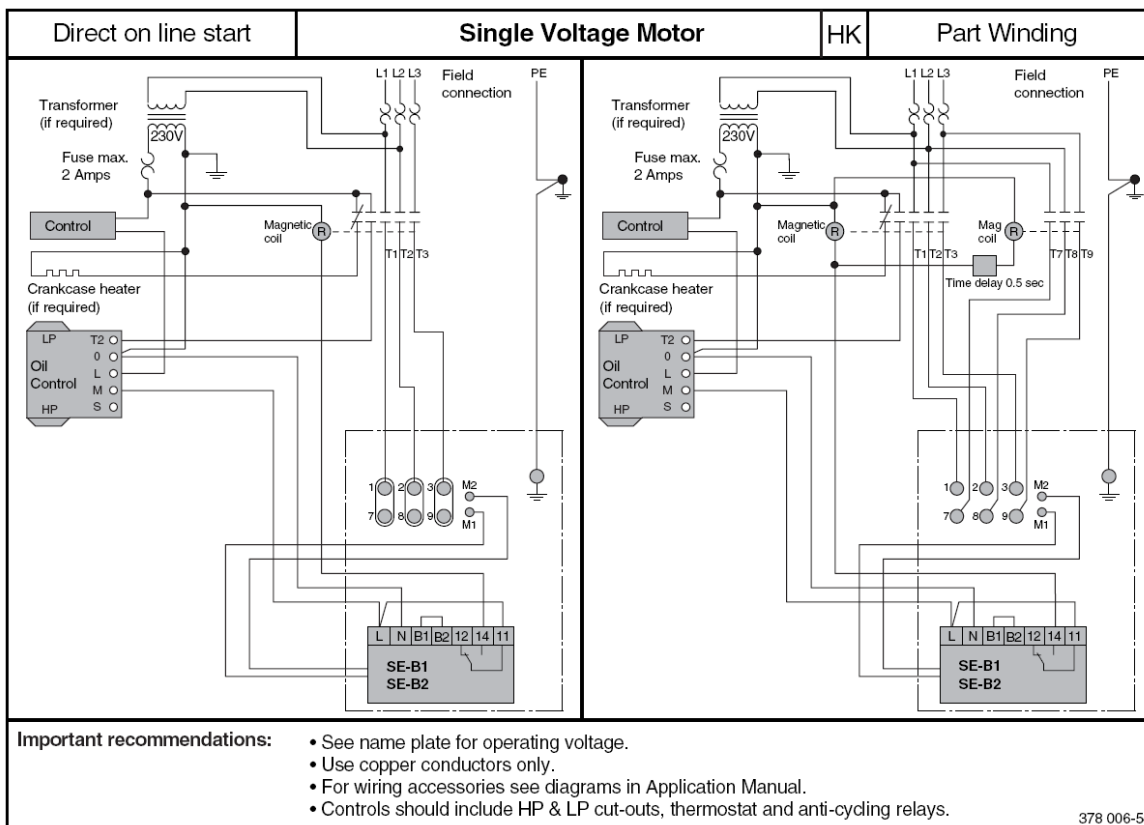
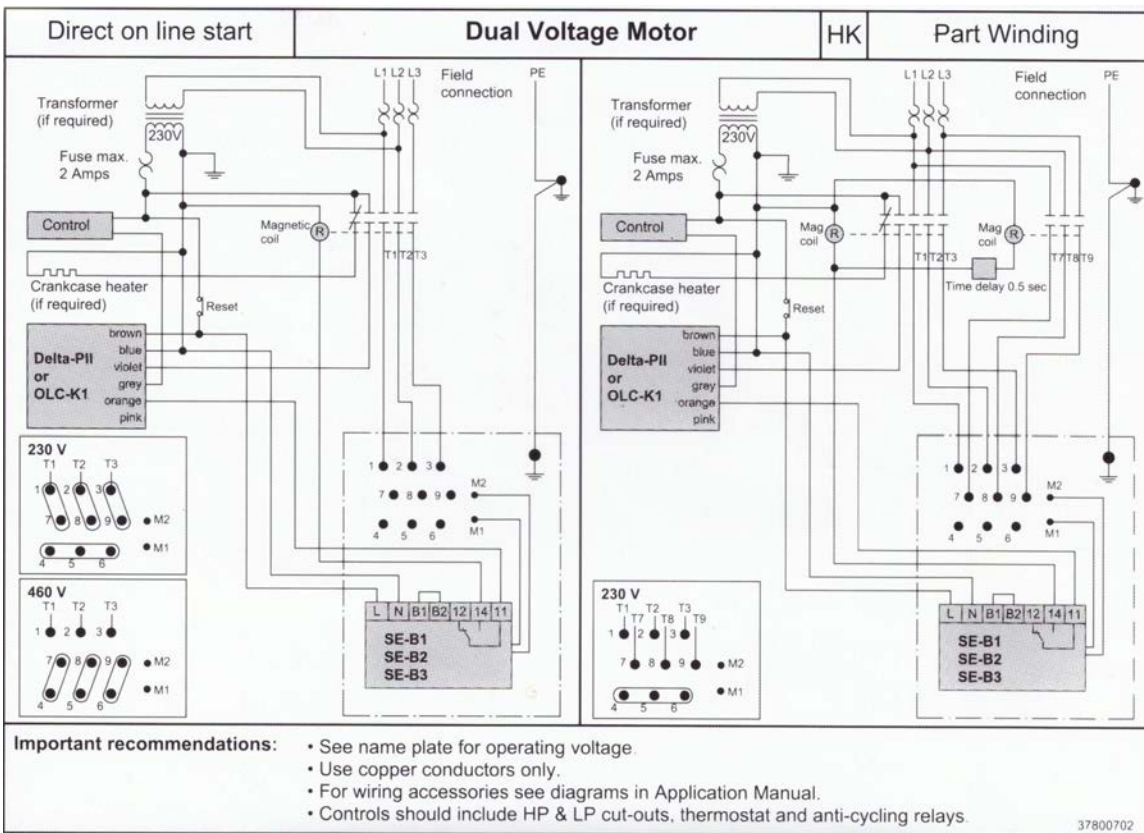

# Wiring Diagram Appendix



**DANGER OF ELECTROCUTION!!!**

**ALL WORK TO BE PERFORMED BY A TRAINED PROFESSIONAL**

**!!!ATTENTION!!!**

**WIRING SCHEMATICS ARE DIFFERENT FOR EVERY SYSTEM. THESE DRAWINGS ARE PROVIDED ONLY FOR REFERENCE AND MAY NOT BE USED LITERALLY.**

**CONSULT SYSTEM MANUFACTURER OR OTHER QUALIFIED SYSTEM ENGINEER IF UNSURE OF REWIRING**

## Installing the BITZER INT (motor protection device: "SE-B")

General directions (may not be applicable depending system):

1. Use 11 and 14 of the BITZER INT as part of the control circuit to replace M1 and M2 of the Copeland Module.
2. Use L and N on the INT to replace the line power T1 and T2.
3. Make sure the orange wires of the INT are connected to thermistors on the compressor terminal plate.
4. 11 and 14 will close when INT has power and the thermistors have resistance below 2700 Ω.
5. If the resistance is greater than 4500 Ω, the module will trip. Disconnect power at L or N for 5 seconds to reset.
6. If possible, maintain separate power to L from 11 so the BITZER INT cannot be reset accidentally or be an electronic controller

### Replacing Copeland Models That Have No Overload (3Ds)

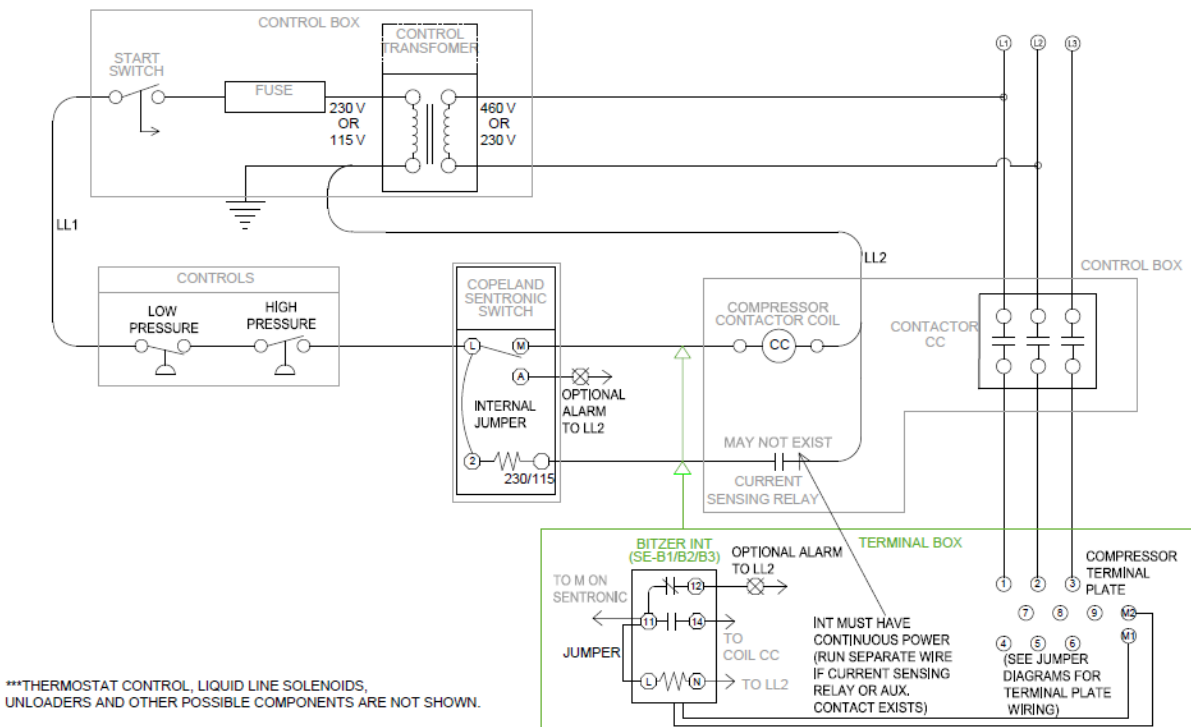



### Replacing Copeland Overload Module with BITZER INT

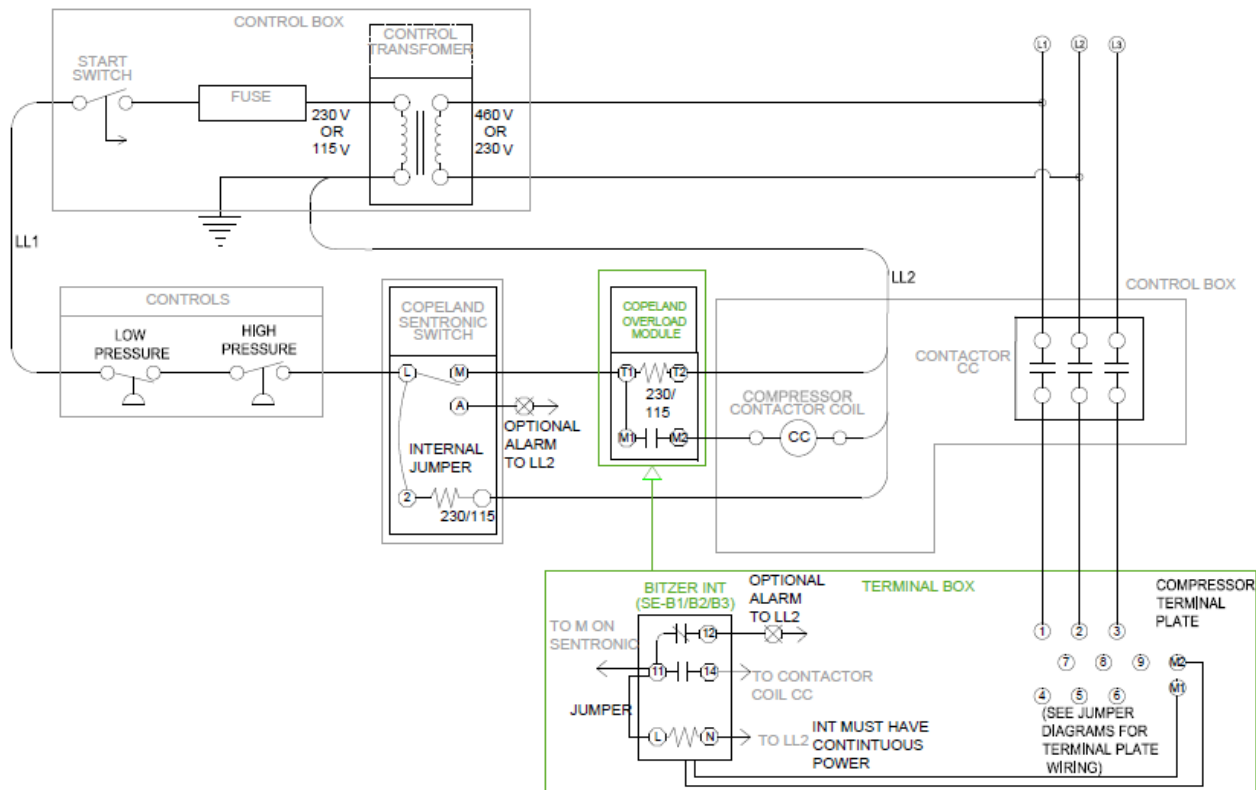

### Using the OLC/K1 or Delta- PII Oil Control

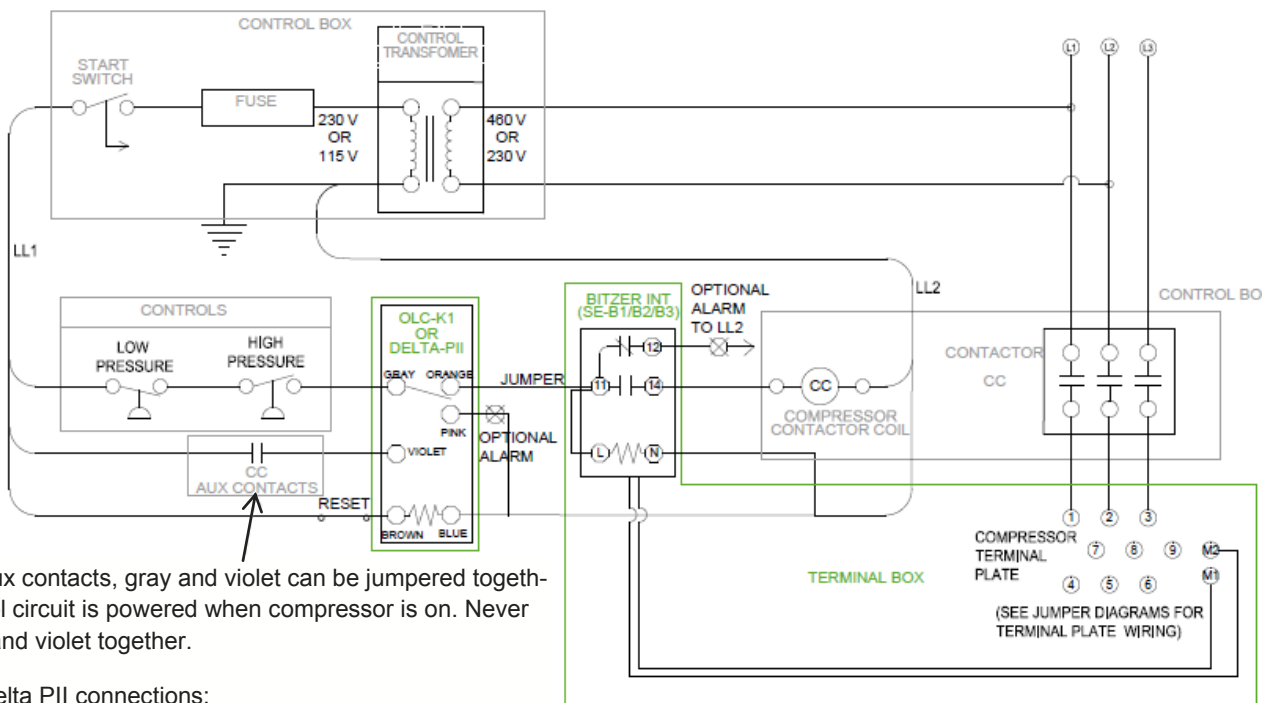

In lieu of NO aux contacts, gray and violet can be jumpered together only if control circuit is powered when compressor is on. Never jumper brown and violet together.

OLC-K1 and Delta PII connections:

- Brown and blue power the unit
- Gray and orange are the control circuit relays
- Violet is the run proof for on-delay timers
- Pink (and gray) is alarm circuit

Note: Thermostat control, liquid line solenoids, unloaders and other possible components are not shown.

### Wiring the BITZER CIC & INT280

Master Wiring Diagram Using SE-B Module, Delta-PII, CIC and INT 280

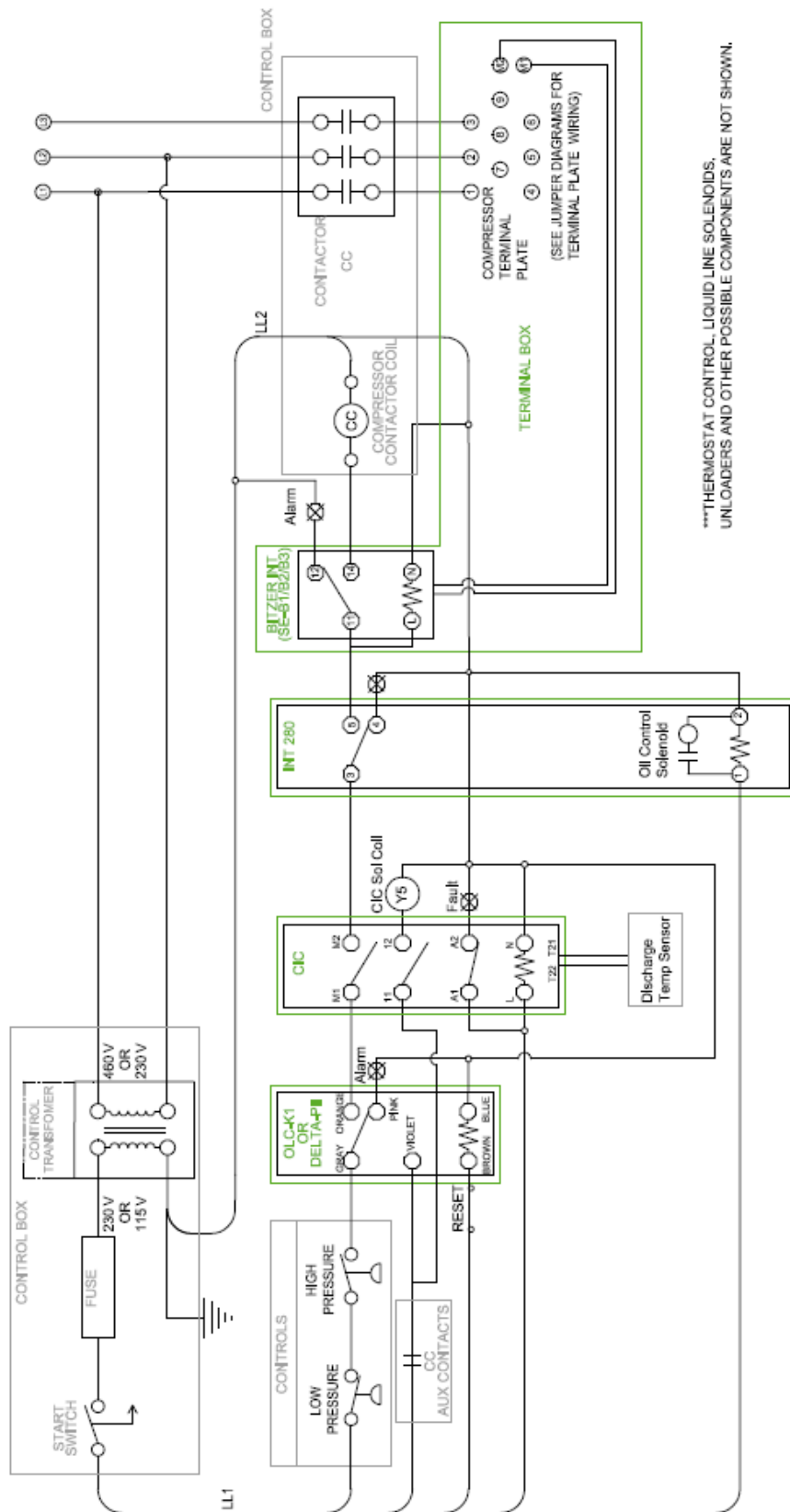

For more information, refer to BITZER Technical documentation KT-130.



## Installing the Terminal Box Plate Adapter (p/n 999-0024-01)

1. Remove the BITZER terminal box cover from the compressor (6 Phillips head screws).
2. Remove the ground lug from the terminal plate. Save the lug, it will need to be reinstalled later.
3. Remove the SE-B module from the terminal box (2 Phillips head screws)
4. Remove the BITZER terminal box and save the mounting screws (4 Phillips head screws).
5. Place the adapter plate (YY) over the terminal plate of the BITZER compressor.

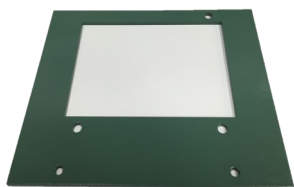

YY

Keep in mind the slanted part of the Copeland terminal box will be connected to the 4 hole side of the adaptor plate.

6. Using 3 of the 4 terminal box screws saved from step 4, install the terminal plate adaptor onto the terminal plate at the position indicated by the **RED CIRCLES**. (Torque - 7ft lb / 9Nm)

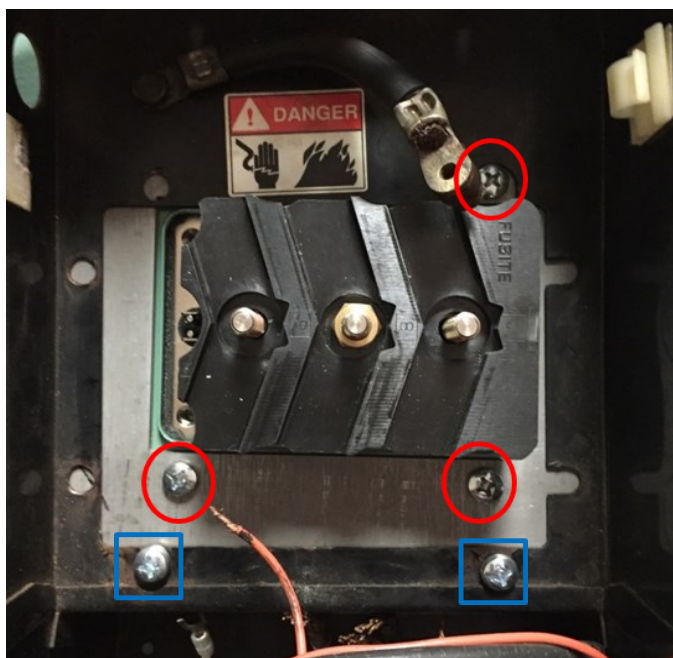

7. Place the Copeland terminal box on the adapter plate and use the 2 M6 x 15 (ZZ) screws at the position indicated by the **BLUE SQUARES** to secure the terminal box. (Torque - 7ft lb / 9Nm)



ZZ

8. Reinstall the grounding lug (not shown) on the terminal plate. (Torque - 7ft lb / 9Nm)
9. Reinstall the SE-B Module.



## Installing the Pressure Switch Plate (p/n 999-0026-01)

1. Remove the bolts located at 5 and 7 o'clock on the oil pump.
2. Install the hex head studs. Torque to 22ft lb (30 Nm).



3. Install the bracket with the lock washers and nuts provided. Torque to 22ft lb (30 Nm).



4. Use the predrilled holes to mounts the existing pressure switches. (Hardware not included.)

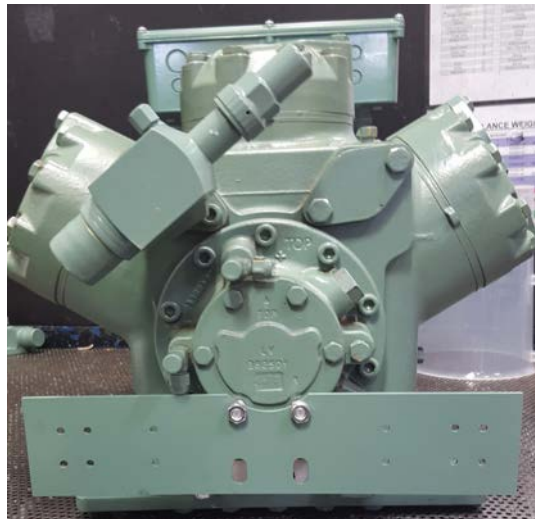



## Installing the Resistor Pack (p/n 999-0028-01)

1. Remove the BITZER terminal box cover from the compressor (6 Phillips head screws).
2. Use the double sided tape to mount the Resistor Pack to the inside of the Terminal Box.
3. Connect the **Common**, **S1**, **S2** and **S3** wires from the CoreSense to the Resistor Pack.

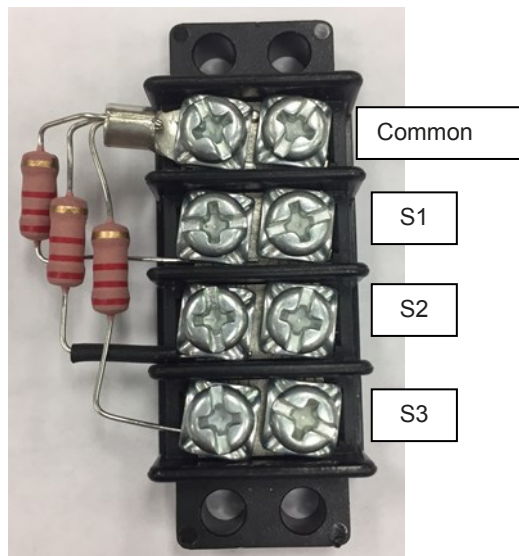

4. Mount the existing CoreSense module. See example below. (Hardware not included)





Observation	Possible Cause	Trouble Shooting Steps
<b>Compressor is not running</b>	Loss of power	Check voltage between phases before and after breaker, contactor and at the terminal box. Check voltage between the contactor coil.
	Overload protection (INT) tripped	Check resistance between M1 and M2. If resistance is lower than 1000 ohms, reset the INT. If the resistance is greater, check motor windings, supply voltage and ensure connections are tight.
	Burnt motor	Check windings. Check continuity and resistance between windings. All windings should have the same resistance of about 1 ohm and should show continuity. Also check continuity and resistance between each pin and ground. Resistance should be at least 50 Megaohms (non-continuous).
	Other protections tripped	Check continuity for all control circuit devices (e.g. low/high pressure switches, phase loss, oil failure, etc)
<b>Compressor is noisy</b>	Broken reeds	Check suction and discharge pressure. Turn off the compressor and look for the pressures to equalize. If the pressures equalize almost immediately, change valve plate.
	Wet suction	Check superheat on the suction side of the compressor (superheat should be at least 20° F). Adjust TXV to the appropriate superheat.
	Broken rod	Check for heavy vibrations. Replace compressor.
<b>Compressor leaking</b>	Gaskets / o-rings	Tighten bolts according to the torque chart. If the problem is not solved then change the gasket or o-ring. Inspect mating surfaces when changing gaskets. Only use BITZER gaskets / o-rings.
	Oil adapter / sight glass	Replace the oil adapter.
<b>Oil pump</b>	Low pressure differential	Minimum pressure differential is 9psi. Check oil level at the sightglass. Reverse the rotation by changing two phases of the power supply, look for improvement. If no improvement, change oil pump.
	No pressure differential	Open oil pump. If the oil pump bearing is worn, change the complete oil pump.
	Oil level low	Add oil and check for leaks.
<b>Flooded start</b>	Crankcase heater	May not be operating or installed. Crankcase heater remains on when compressor is off.
	Piping	Piping is allowing liquid to enter the compressor when the compressor is off. Change piping and/or install check valve.
	Migration	Ensure proper crankcase heating. If the compressor is outdoors, use housing or machining room.
<b>Flood back</b>	Suction line frozen	Check superheat at evaporator. Adjust TXV.
	Liquid coming back	Clean evaporator coil.

## 10.0 Troubleshooting



Observation	Possible Cause	Trouble Shooting Steps
<b>Compressor is running hot</b>	High discharge	Ensure condenser is operating and clean.
	Suction temp high	Check return gas temperature.
	Compression ratio is too high	Check set points and application limits.
<b>Oil failure trips</b>	No oil at sightglass	Check for leaks and check piping. Possibility of improper traps.  Possibility of liquid refrigerant in the crankcase.  Too much oil in the system.
<b>Oil failure trips</b>	Oil at normal level	
<b>Oil failure trips</b>	Oil sightglass full	



Bitzer model number \_\_\_\_\_ Date \_\_\_\_\_  
 Serial Number \_\_\_\_\_ Location \_\_\_\_\_  
 Compressor/equipment bought from \_\_\_\_\_ Tech name \_\_\_\_\_  
 \_\_\_\_\_ Phone \_\_\_\_\_

Refrigerant		
Set points		Parallel system
Suction pressure		Condensing unit (remote)
Discharge pressure		Chiller (self contained)

Defrost	
Quantity	
Duration (mins)	
Type (air, electric or gas)	
System description	

DATA	Voltage between phases	/ /	Comments
Date	Amps per phase	/ /	
Time			
Suction pressure	psi Oil level at sightglass	/8	
Discharge pressure	psi Oil color		
Suction temp	F Any foam?	YES/NO	
Discharge temp	F Oil pump (pressure dif)	psi	
Compressor superheat	F Condenser clean?	YES/NO	
Evaporator superheat	F Fans running?	YES/NO	
Liquid temp	F Using subcooler	YES/NO	
Any noise?	YES/NO		
	Other protections		
	Low pressure switch		
	High pressure switch		
	Phase loss		
	Oil failure		





# Notes

**BITZER US, Inc.**

4080 Enterprise Way  
Flowery Branch, GA 30542  
Phone: 770-503-9226  
Fax: 770-503-9440  
Email: [sales@bitzerus.com](mailto:sales@bitzerus.com)  
[www.bitzerus.com](http://www.bitzerus.com)

**24h Emergency Replacement Hotline for US Customers:**  
1.888.GO BITZER (1.888.462.4893)

**BITZER Canada, Inc.**

21125 Daoust Street  
Sainte-Anne-De-Bellevue, Quebec, Canada  
H9X 0A3  
Phone: 514-697-3363  
Fax: 514-697-9768  
[www.bitzer.ca](http://www.bitzer.ca)

**BITZER Mexico S. de R.L. de C.V.**

Av. Adolfo López Mateos 221, Bodega 9, Col. Victoria  
67110 Guadalupe, N.L., Mexico  
Phone: +52 (81) 1522 4500  
Fax: +52 (81) 1522 4505  
[www.bitzermexico.com](http://www.bitzermexico.com)

**BITZER LATIN AMERICA**

[colombia@bitzerus.com](mailto:colombia@bitzerus.com)  
[ecuador@bitzerus.com](mailto:ecuador@bitzerus.com)  
[puertorico@bitzerus.com](mailto:puertorico@bitzerus.com)  
[caribe@bitzerus.com](mailto:caribe@bitzerus.com)  
[centroamerica@bitzerus.com](mailto:centroamerica@bitzerus.com)  
[venezuela@bitzerus.com](mailto:venezuela@bitzerus.com)