



ESH7 Scroll Compressors



Cross Reference Guide

Bristol / Copeland / Danfoss / Maneurop / Tecumseh / Trane

Model Number^{1,2} Cap.³ Mbh OH Overall Height MB Mtg Base Holes ϕ Suction Conn. Discharge Conn. Available Voltages

BITZER Scroll Compressor

ESH725-*SU	103.5	23.0"	8.66" sq.	1-1/8"	7/8"	2 - 208-230/3/60 4 - 460/3/60 5 - 575/3/60
ESH730-*SU	124.2	23.0"	8.66" sq.	1-1/8"	7/8"	
ESH736-*SU	149.1	23.0"	8.66" sq.	1-1/8"	7/8"	
ESH743-*SU	188.6	25.2"	8.66" sq.	1-3/8"	1-1/8"	

Accessories for BITZER Scrolls

Sweat Adapters

366030-01	1-1/8" Suction and 7/8" Discharge for ESH725, ESH730 and ESH736
366024-01	1-3/8" Suction and 1-1/8" Discharge for ESH743

Shut-Off Valves

361395-01	1-1/8" Suction and 7/8" Discharge for ESH725, ESH730 and ESH736
361393-04	1-3/8" Suction and 1-1/8" Discharge for ESH743

Crankcase Heaters

892-0070-05	70 watt, 120V	Please note that the control voltage must be specified at time of order to ensure that the correct motor protection module is supplied with compressor.
892-0070-06	70 watt, 240V	
892-0070-07	70 watt, 460V	
892-0070-08	60 watt, 575V	

Tandem Kits

200-0004-02	ESH725, ESH730 and ESH736
200-0004-01	ESH 743

Optional Discharge Temperature Sensor for added protection

347023-06	284°F
-----------	-------

Oil for R22, A/C applications - please use only Bitzer approved oils

For HCFC's:	793-1150-24 B5.2 Alkylbenzene, 1 U.S. Gal.
For HFC's:	793-1031-34 BSE32 POE, 1 U.S. Gal.

Notes:

- For additional technical specifications, see brochure **ESP-105-5**
- Replace '*' with applicable voltage code from above. i.e. ESH730-5SU for 575/3/60
- Capacity Rating at 45°F SST, 130°F SDT, 65°F RGT and 0°F Subcooling using R22.

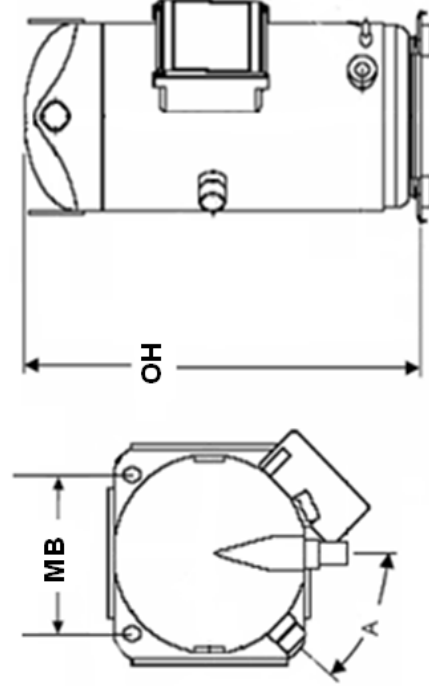

Model Number ¹	R - Recip		Height ³ Mtg Base	Suction (RL - Rotolock / S - Sweat)	Discharge	
	S - Scroll	Cap. ² Mbh				
Bristol						
H2*G094D	R	87.7	17.41"	9.5" sq.	1-1/8"S	7/8"S
H2*G104D	R	101.8	18.16"	9.5" sq.	1-1/8"S	7/8"S
H2*G124D	R	119.0	18.16"	9.5" sq.	1-1/8"S	7/8"S
H2*G144D	R	114.1	22.41"	10.5" sq.	1-1/8"S	7/8"S
H2*G184D	R	183.2	22.41"	10.5" sq.	1-3/8"S	1-1/8"S
Bristol 2-Speed⁴						
H2NG094GP	R	87.7	17.41"	9.5" sq.	1-1/8"S	7/8"S
H2NG104GP	R	101.8	18.16"	9.5" sq.	1-1/8"S	7/8"S
H2NG124GP	R	119.0	18.16"	9.5" sq.	1-1/8"S	7/8"S
H2NG144GP	R	144.1	22.41"	10.5" sq.	1-1/8"S	7/8"S
H2NG184GP	R	183.2	22.41"	10.5" sq.	1-3/8"S	1-1/8"S
Copeland						
BRD*-0750	R	90.0	18.44"	8.66" sq.	1-1/8"S	3/4"S
BRF*-0750	R	97.0	18.44"	8.66" sq.	1-1/8"S	3/4"S
BRG2-0900	R	110.0	18.44"	8.66" sq.	1-1/8"S	3/4"S
BRH2-1000	R	125.0	18.44"	8.66" sq.	1-1/8"S	3/4"S
BRK*-1200	R	150.0	18.44"	8.66" sq.	1-1/8"S	3/4"S
QR11M1-TFC	R	102.0	18.44"	8.66" sq.	1-1/8"S	3/4"S
QR12M1-TFC	R	115.0	18.44"	8.66" sq.	1-1/8"S	3/4"S
QR15M1-TFC	R	142.0	18.44"	8.66" sq.	1-1/8"S	3/4"S
ZB58KC	S	96.5	18.75"	7.50" sq.	1-1/8"S or RL	7/8"S or RL
ZB66KC	S	109.0	21.0"	7.50" sq.	1-3/8"S or RL	7/8"S or RL
ZB75KC	S	118.0	21.17"	8.65" sq.	1-3/4-RL	1-1/4 RL
ZB76KC	S	128.0	21.0"	7.50" sq.	1-3/8"S or RL	7/8"S or RL
ZB88KC	S	146.0	21.0"	7.50" sq.	1-3/8"S or RL	7/8"S or RL
ZB92KC	S	150.0	21.47"	8.65" sq.	1-3/4-RL	1-1/4 RL
ZB95KC	S	156.0	21.71"	7.50" sq.	1-3/8"S or RL	7/8"S or RL
ZB114KC	S	185.5	21.71"	7.50" sq.	1-3/8"S or RL	7/8"S or RL
ZR11M3	S	108.0	21.20"	8.65" sq.	1-3/8"S or RL	7/8"S or RL
ZR12M3	S	125.0	21.20"	8.65" sq.	1-3/8"S or RL	7/8"S or RL
ZR16M3	S	154.0	21.50"	8.65" sq.	1-3/8"S or RL	7/8"S or RL
ZR19M3	S	190.0	23.30"	8.65" sq.	1-5/8"S or RL	1-1/8"S or RL
ZR90K3	S	89.0	21.20"	8.65" sq.	1-3/8"S or RL	7/8"S or RL
ZR94KC	S	96.5	18.8"	7.50" sq.	1-1/8"S or RL	7/8"S or RL
ZR108KC	S	109.0	21.0"	7.50" sq.	1-3/8"S or RL	7/8"S or RL
ZR125KC	S	127.0	21.0"	7.50" sq.	1-3/8"S or RL	7/8"S or RL
ZR144KC	S	146.0	21.71"	7.50" sq.	1-3/8"S or RL	7/8"S or RL
ZR160KC	S	160.0	21.71"	7.50" sq.	1-3/8"S or RL	7/8"S or RL
ZR190KC	S	190.0	21.71"	7.50" sq.	1-3/8"S or RL	7/8"S or RL

Notes:

1. Use only as a guide! Actual dimensions and performance of existing compressor must be confirmed.
2. Capacity Rating at 45FSST, 130FSST, 65RGT and 0F Subcooling using R22.
3. Maneurop mounting height includes rubber mounts.
4. Rewiring of control circuit to single speed will be required when replacing with a BITZER scroll.

Model Number ¹	R - Recip		Height ³ Mtg Base	Suction (RL - Rotolock / S - Sweat)	Discharge	
	S - Scroll	Cap. ² Mbh				
Danfoss						
HCM094	S	94.0	21"	7.50" sq.	1-1/8"S	7/8"S
HCM109	S	109.0	21"	7.50" sq.	1-1/8"S	7/8"S
HCM120	S	120.0	21"	7.50" sq.	1-1/8"S	7/8"S
SM090	S	90.1	20"	8.66" sq.	1-1/8"	3/4"
SM100	S	94.1	20"	8.66" sq.	1-1/8"	3/4"
SM110	S	107.8	22"	8.66" sq.	1-3/8"	7/8"
SM115	S	115.2	22.9"	8.5x12"	1-3/8" or RL	7/8" or RL
SM120	S	125.4	22"	8.66" sq.	1-3/8"	7/8"
SM125	S	126.4	22.9"	8.5x12"	1-3/8" or RL	7/8" or RL
SM148	S	149.6	23.3"	8.66" sq.	1-3/8"	7/8"
SM160	S	163.0	24.9"	8.5x12"	1-5/8" or RL	1-1/8" or RL
SM161	S	162.6	23.3"	8.66" sq.	1-3/8"	7/8"
SM175	S	174.4	26.7"	11x12"	1-5/8" or RL	1-1/8" or RL
SM185	S	185.5	26.7"	11x12"	1-5/8"S or RL	1-1/8"S or RL
Maneurop						
MT100	R	95.9	20.4"	9.685 sq.	1-1/8"S or RL	3/4"S or RL
MT125	R	124.7	20.4"	9.685 sq.	1-1/8"S or RL	3/4"S or RL
MT144	R	140.7	21.18"	9.685 sq.	1-1/8"S or RL	3/4"S or RL
MT160	R	156.8	21.18"	9.685 sq.	1-1/8"S or RL	3/4"S or RL
Tecumseh						
AN5590G/E(F/H)	R	92.5	26"(20")	8.6" sq.	1-1/8"S or RL	3/4"S or RL
AN5610G/E(F/H)	R	100.0	26"(20")	8.6" sq.	1-1/8"S or RL	3/4"S or RL
AN5612G/E(F/H)	R	122.0	26"(20")	8.6" sq.	1-3/8"S or RL	3/4"S or RL
AN5614G/E(F/H)	R	140.0	26"(20")	8.6" sq.	1-3/8"S	3/4"S
SF*5594	O	93.5	18.61"	7.5" sq.	1-3/8"S	3/4"S
SF*5611	O	107.0	18.61"	7.5" sq.	1-3/8"S	3/4"S
SF*5612	O	127.0	18.61"	7.5" sq.	1-3/8"S	3/4"S
SF*5615	O	150.0	18.61"	7.5" sq.	1-3/8"S	3/4"S
Trane						
CRHH-083	R	85.0	17.66"	8.5" sq.	1-1/8"	5/8"
CRHL-100	R	99.7	19.71"	8.5" sq.	1-3/4-RL	1-1/4 RL
CSHA/B/S-093	S	117.5	22.2"	8.5x12"	7/8"	1-3/8"
CSHA/B/S-100	S	125.0	22.2"	8.5x12"	7/8"	1-3/8"
CSHA/S-140	S	174.0	26.4"	11x12"	1-5/8"	1-1/8"
CSHA/S-150	S	185.0	26.4"	11x12"	1-5/8"	1-1/8"

BITZER U.S., Inc.

4031 Chamblee Road
Oakwood, GA 30566

Phone: 770-503-9226

Fax: 770-503-9440

Email: sales@bitzerus.com

24h Emergency Replacement Hotline for US Customers:

1.888.GO BITZER (1.888.462.4893)

BITZER Canada, Inc.

930 Selkirk Street
Pointe Claire, Quebec, Canada
H9R 4T7

Phone: 514-697-3363

Fax: 514-697-9768

www.bitzer.ca

BITZER Mexico S. de R.L. de C.V.

Estanislao Martinez Lara No. 29
Parque Industrial Milimex
66390 Santa Catarina N.L., Mexico

Phone: +52 (81) 1522 4504

Fax: +52 (81) 1522 4505

www.bitzermexico.com